

ACOUSTICAL CEILING SYSTEMS



USG BORAL
INNOVATION INSPIRED BY YOU.™



[USGBoral.com](https://www.usgboral.com)

Plasterboard

Ceilings

Interior Finishes

Metal Framing

Substrates

©2018 Factory of USG Boral Middle East LTD. Co. All rights reserved. The trademarks USG BORAL and INNOVATION INSPIRED BY YOU are the trademarks of Factory of USG Boral Middle East LTD. Co. The trademarks DUROCK, FIBEROCK, FIRECODE, MOLD TOUGH, PLUS 3, MID-WEIGHT, SECUROCK, SHEETROCK, AND TUFF-HIDE are the trademarks of U.S. Gypsum Company and used under license. VER. 03-2018/2019



**USG BORAL ME
IS COMMITTED
TO PROVIDE
INNOVATIVE
ARCHITECTURAL
FINISHES
& SOLUTIONS
INSPIRED
BY YOU**

WHY CHOOSE USG BORAL MIDDLE EAST?

USG Boral Middle East is the only manufacturer of mineral fiber tiles in the Middle East and complies with both international standards ASTM E1264 and EN 13964 for ceiling tile manufacturing.

USG Boral ME offers a wide range of high quality aluminum alloy and metal ceiling system that increase the aesthetic and functional value of your interiors within a modest ceiling budget.

USG Boral ME famous DONN® grid suspension is manufactured locally and is certified to meet the most stringent national standards and to adhere with all relevant building codes and norms.

USG Boral ME is dedicated to provide high quality products to the full satisfaction of its customers, in compliance with the statutory and regulatory requirements, through a well-established quality management system that complies with the ISO 9001:2015 standard.

USG Boral ME maintains a longstanding commitment with its employees, customers and communities to reduce environmental impact use recycled materials whenever feasible and eliminate manufacturing waste. USG Boral ME products contribute toward LEED® credits in different areas.

The company has a technical team that offers technical support for Mega projects at no cost whenever it is required by the clients, consultants or contractors.



Acoustical
Ceiling



Logix Integrated
Ceilings



Metal
Ceiling



Suspension
Systems



CONTENTS

Products Selection	06-15
Product Application	
Norm Compliance	
ASTM E1264	
ASTM Standards Compliance Table	
EN 13964	
Acoustical Ceiling Selectors	
Size	
Edge Details	
Light Reflectance	
Acoustical Performance	16-19
Fire Safety	20-22
Environmental Statement	23
USG Boral ME & Sustainability	24-28
LEED Leadership in Energy & Environmental Design	
Recycle Content	
Sustainability Table	
Mold Prevention	29
Environmental Air Quality	30-31
Health Comfort	
Indoor Air Quality	
Cleanliness	
Water Shield	
Thermal Resistance	32-33
Acoustical Ceiling	34-107
Metal Ceiling	108-119
DONN®DX/DXL Grid Suspension System	120-151
Grid Edge Details	
Guide Specifications 09120	
Seismic Solutions	
USG Boral ME Terms & Conditions	152-157
Packaging “For Ceiling System”	158-159
Ceiling	
Grid	
Warranties and Limitations	160-161

PRODUCT SELECTION

USG Boral ME offers ceiling systems for every type of building area. You can find ceiling systems by industries or use purpose.

EDUCATION

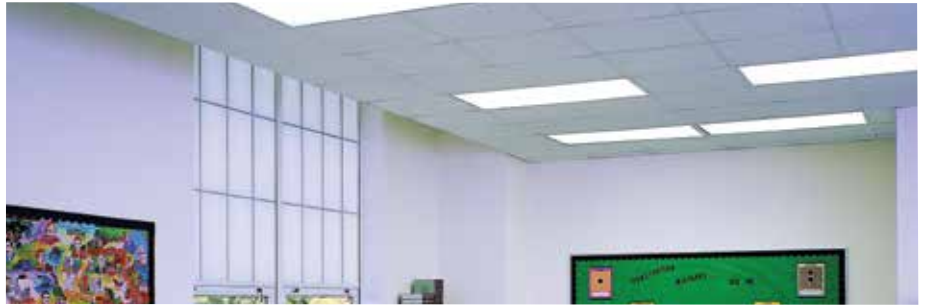

ADMINISTRATION



SPORT/ LEISURE



RETAIL



HOSPITALITY



HEALTHCARE



PRODUCTION AREAS



PRODUCT APPLICATION

Product Application Table

	Airports	Banks	Boardrooms Conferences	Cinemas Theaters	Computer Rooms	Factories Workshop	Food Halls	Gymnasiums	Hospitals Medical Centers	Laboratories Cleanrooms	Wet Areas	Libraries	Light Industrial Construction	Lobbies Receptions	Corridors	Offices	Open Plan Offices	Restaurants Cafes	Retail	Schools	Service Stations	Shopping Centers	Showrooms Exhibition
Athena					M	M						M		M	M	M			M	M			
Chessboard					M	M							M		M				M		M		
Clean Room™							P		P	P	P		M										
Comet Line					M	M									M				M		M		
Cross Fissured					E	E						E	M		E				E		E	E	
Designer series					M	M								M		M			M		M		M
Favia						E	E					E	M		E	E			E		E	E	
Favia Acoustic				M	M	M	M	M					E		M	M			M	M			
Frost™	P	P	P	P								P		P		P	P			P			P
Glacier™	P	P	P	P								P		P		P		P					P
Halcyon™/Halcyon HC		P	P	P	P				P	P		P		P			P			P			P
Logix™, Sonata, Halcyon™ & Mars™	P	P	P	P					P			P		P		P	P						P
Louna		P	P		P							P		P	P	P	P	P		P		P	P
Louna HI CAC	P			P				P										P		P		P	P
Metal Face					E				P	P	P			P									
Mars™		P	P				P		P	P	P	P		P	P	P	P	P		P			P
Olympia II™		E			E							E		E	E	E		E	E			E	E
Olympia Micro™						M		M					E	M	M	M	MR	M	M	M		M	M
Omni						E									E	E			E		E	E	
Pedestal		MR			MR	MR							E						MR		MR		MR
Perforated					M	M						M	MR	M	M	M			M	M			
Radar™	MR	E		E	E							E	M		E	E	MR	E	E	E		E	MR
Radar Ceramic							P						E										
Sandrift™		P	P	P								P		P		P		P					P
Skyrock Classic		P	P	P	P							P		P			P			P			P
Skyrock Nordic		P	P	P	P							P		P			P			P			P
Sonata	P	P	P				P	P	P	P		P		P	P	P	P	P	P	P		P	P
Sonata healthcare									P	P													
Sparta					E		E		E		E	E				E		E	E			E	
Plain													E	M		M		M	M			M	
Taiga Hygiene							MR		MR	MR								MR	MR				
Wood Tone	P			P											P			P				P	P

E Economical M Moderate MR Mid-Range P Premium

Products Selection

	Type	Form	Pattern	Texture	Fire Reaction	Fire Rated	Thermal Resistance (m ² k/w)		Washability	Abuse Resistance	Humidity Resistance(%RH)	Antibacterial
							15mm	19 25mm				
Athena	III	2	C,E	Fine	Class A		0.23	0.31	Yes		99%	
Chessboard	III	2	E,K	Scored	Class A			0.31			90%	
Clean Room™	X	2	C,G,I	Smooth	Class A	Yes	0.23		Yes		99%	Inherent
Comet Line	III	2	E,K	Scored	Class A			0.31			90%	
Cross Fissured	III	2	C,D	Medium	Class A	Yes	0.23	0.31			90%	
Designer series	III	2	C,D,E,G,K	Scored	Class A			0.31			90%	
Favia	III	2	D,E	Fine	Class A		0.23				95%	
Favia Acoustic	III	2	C,D,E	Fine	Class A		0.23	0.31			95%	
Frost™	III	4	E	Fine	Class A			0.33		Yes	95%	
Glacier™	III	4	F	Heavy	Class A	Yes		0.33		Yes	95%	
Halcyon™/Halcyon HC	XII	2	E,G	Fine	Class A			0.6/0.74	Yes		99%	Inherent
Logix™, Sonata, Halcyon™ & Mars™	IV,XII	1,2	E,G	Fine	Class A		0.23	0.31/0.6	Yes		95%	Yes
Louna	XII	2	G	Fine	Class A	Yes		0.6/0.74	Yes		99%	Inherent
Louna HI CAC	XII	2	G	Fine	Class A	Yes		0.6/0.74	Yes		99%	Inherent
Metal Face	X	2	B,C,I	Fine	Class A	Yes	0.23		Yes		99%	Yes
Mars™	IV	1,2	E,G	Fine	Class A		0.23	0.31	Yes		95%	Yes
Olympia II™	III	2	E	Fine	Class A	Yes	0.23	0.31			99%	
Olympia Micro™	III	2	C,E	Fine	Class A	Yes	0.23	0.31			99%	
Omni	III	2	C,D,E	Medium	Class A	Yes		0.31	Yes		95%	
Pedestal	III	2	E,G	Smooth	Class A		0.23	0.31			95%	
Perforated	III	2	C,E	Fine	Class A		0.23	0.31	Yes		99%	
Radar™	III	2	C,D,E	Fine	Class A	Yes	0.23	0.31			99%	
Radar Ceramic	XX	2	C,D,E	Fine	Class A	Yes		0.31		Yes	100%	Inherent
Sandrift™	III	4	Z	Medium	Class A	Yes		0.33		Yes	95%	
Skyrock Classic	XII	2	G	Fine	Class A			0.6/0.74	Yes		95%	
Skyrock Nordic	XII	2	G	Fine	Class A			0.6/0.74	Yes		95%	
Sonata	IV	2	E,G	Fine	Class A	Yes	0.23	0.31	Yes		99%	Yes
Sonata healthcare	IV	2	E,G	Fine	Class A	Yes		0.31	Yes		99%	Yes
Sparta	X	2	G	Smooth	Class A		0.23	0.31			99%	Inherent
Plain	III	2	G	Smooth	Class A		0.23	0.31			95%	
Taiga Hygiene	III	2	G	Smooth	Class A			0.31			99%	Yes
Wood Tone	III	2	G	Smooth	Class B			0.31	Yes		95%	

NORMS COMPLIANCE

USG Boral ME products are classified according to ASTM E1264 and are CE Marking per EN 13964. These norms aim for easy comparison between various types of Ceiling systems.

ASTM E1264

USG Boral ME Ceiling products meet ASTM E1264 in:

1. Ceiling Types:

Type III: Mineral base with painted finish (Auratone)

Type IV: Mineral base with membrane-faced overlay (Sonata, Clean Room)

Type X: Mineral base with Plastic or Aluminum membrane- faced overlay, or both (Sparta)

Type XII: Glass fiber base with membrane-faced (Halcyon™, Louna)

Type XIII: Aluminum or Steel strip (Pan) with mineral or fiber glass fiber base Infill (Metal Ceiling)

Type XX: Other types (Radar™ Ceramic™, True™ Wood™, Luminous™ ...)

2. Ceiling Forms For Mineral Base (1, 2, 4)

The Mineral Fiber Manufacturing process is composed from a combination of naturally occurring, processed and recycled materials in varying proportions depending upon the tile type: mineral wool, clay, perlite, cellulose and starch mixed together in a water based process before being cured by heat. They are then finished with either a water based paint, or laminated scrim and paint or decorative facing.

Three technologies allow considerable variation in the product's density and porosity which can be used to positively influence a wide range of technical performances of the finished products:

Form 1: Nodular (X-Technology): "X" Technology is a unique manufacturing method which was developed and introduced to the market by USG in 1989. This technology produces ceiling panels with ClimaPlus™ for sag resistance and High NRC & Smooth Surface. ASTM E 1264, Type III, Form 1 or 2.

Form 2: Water felted: Wet-felted panels are typically mechanically Perforated and fissured. They are very dense and more economical than other types of ceiling panels.

Form 4: Cast or molded: Cast panels are naturally textured and provide a unique, integral color throughout the panel substrate with very good acoustical performance and enhanced extreme durability.

3. Ceiling Patterns (C, D, E, F, G, I, K, Z)

C: Perforated, small holes

D: Fissured

E: Lightly textured

F: Heavily textured

G: Smooth

I: Embossed

K: Surface scored

Z: Other Patterns (describe)

4. Flame Spread Classification:

Smooth, Fine to Medium Textures types of ceiling panels.

Classification	Flame Spread	Smoke Developed
Class A	0-25	0-50
Class B	26-75	
Class C	76-200	
Class D	201	

All USG Boral ME ceiling products have a Class A flame spread rating

5. Additional Classification on:

- A. Acoustical Ratings (NRC, CAC)
- B. Light Reflectance

6. Panel Base Material Type

- A. Regular: STD Board available in 15/19/22 mm
- B. ClimaPlus: for humid resistance application up to 99% RH, 40°C
- C. Fire Code: for fire safety assemblies

EXAMPLES

A. Wet-felt technology ASTM E1264, Type III, Form 2 varying from Smooth, Fine to Medium Textures types of ceiling panels.



B. Cast molding technology ASTM E1264, Type III, Form 4 with special Textures from Fine, Medium to Heavy textures

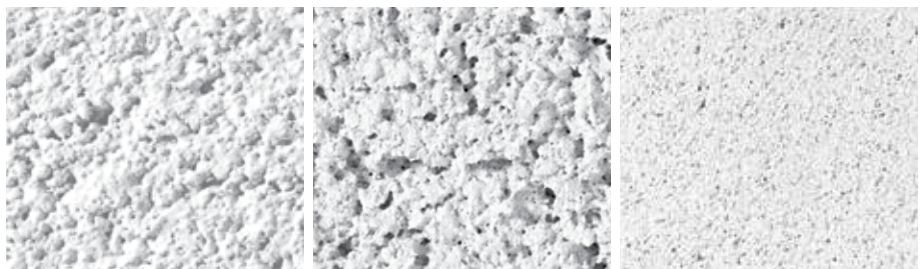

C. X-technology for High NRC & Fine Surfaces ASTM E 1264, Type III, Form 1 or 2



NORMS COMPLIANCE

ASTM Standards Compliance Table USG Boral ME

USG Boral ME CEILING COMPLIANCE WITH ASTM STANDARDS

The following listings contain:

- Existing standard specifications that apply to USG Boral ME Ceiling Systems like E1264, C635 and C645.
- Standards for application of USG Boral ME Ceiling Systems like C636, C754 and E580.
- Standards for performance specifications and test method for various Ceiling properties.

	PRODUCTS FAMILY	ASTM STANDARD																				
		E1264 Acoustical Ceiling Classification	C423 NRC	E1414 CAC	E413 CAC Classification	E1477 LR	D3273 Mold Prevention	D3274 Mold Classification	E84 Surface Burning Characteristics	E119 Fire Resistance	D5116 Total VOC Emission	C518 Thermal Resistance	D2486 Scrubbability	D4828 Washability	C367 Sag/Friability	D1037 Durability	D5420 Impact Resistance	C635 Metal Grid Specs	C636 Grid Installation	C580 Grid with Seismic Restraint	C641 Wire Hangers	
ACOUSTICAL PANELS & TILES	Fissured Family¹	■	■		■			■	■	■	■	■	■	■	■							
	Plain Family²	■	■	■	■			■	■	■	■	■	■	■	■							
	Olympia Micro™ ClimaPlus™	■	■	■	■	■			■	■	■	■	■	■	■							
	Perforated	■	■	■	■	■			■	■	■	■	■	■	■							
	Taiga Hygiene	■	■	■	■	■	■	■	■	■	■	■	■	■	■							
	Laminated Sparta	■	■	■	■	■					■	■	■	■	■							
	Sonata	■	■	■	■	■	■	■	■	■	■	■	■	■	■							
	Clean Room™	■	■	■	■	■			■	■	■	■	■	■	■							
	Radar™ Ceramic	■	■	■	■	■	■	■	■	■	■	■	■	■	■	■	■	■				
	Metal Face	■	■	■	■	■			■	■	■	■	■	■	■							
	Louna	■	■	■	■	■			■	■		■	■	■	■							
	Louna HI CAC	■	■	■	■	■			■	■		■	■	■	■							
	Halcyon™	■	■	■	■	■						■	■	■	■							
	Glacier™	■	■	■	■	■			■	■	■	■	■	■	■	■	■	■				
	Frost™	■	■	■	■	■			■	■	■	■	■	■	■	■	■	■				
	Sandrift™	■	■	■	■	■			■	■	■	■	■	■	■	■	■	■				
	Mars™ ClimaPlus™	■	■	■	■	■	■	■	■	■	■	■	■	■	■	■	■	■				
	Mars™ ClimaPlus™ High NRC	■	■	■	■	■	■	■	■	■	■	■	■	■	■	■	■	■				
	Millenia™ ClimaPlus™	■	■	■	■	■	■	■	■	■	■	■	■	■	■	■	■	■				
	Eclipse™ ClimaPlus	■	■	■	■	■	■	■	■	■	■	■	■	■	■	■	■	■				
	Astro® ClimaPlus	■	■	■	■	■	■	■	■	■	■	■	■	■	■	■	■	■				
	Skyrock Nordic / Classic	■	■	■	■	■			■	■	■	■	■	■	■	■	■	■				
	Wood Tone	■	■	■	■						■		■	■	■							
USG Boral ME Metal Ceiling	■	■			■																	
SUSPENSION SYSTEM	DONN® Grid																	■	■	■		
	Suspension Hangers																					■

LEGEND:

1- Fissured Family includes the following patterns: · Cross Fissured · Omni · Radar™ · Favia (Europa) · Favia Acoustic · Face Cut
 2- Plain Family includes the following patterns: · Taiga™ · Olympia II™ · Comet Line · Chessboard · Pedestal · Face Cut

CE MARKING PER EN 13964

The CE marking (an acronym for the French “Conformité Européenne”) certifies that a product has met EU health, safety, and environmental requirements, which ensure consumer safety. Manufacturers in the European Union (EU) and abroad must meet CE marking requirements where applicable in order to market their products in Europe.

The European Committee for Standardization (CEN) introduced the EN 13964 norm for suspended ceilings which has been mandatory since July 1, 2007. The norm aims to make it easier to compare suspended ceilings. To achieve this, it defines those product characteristics which can or must be declared on product labels and in product documentation.

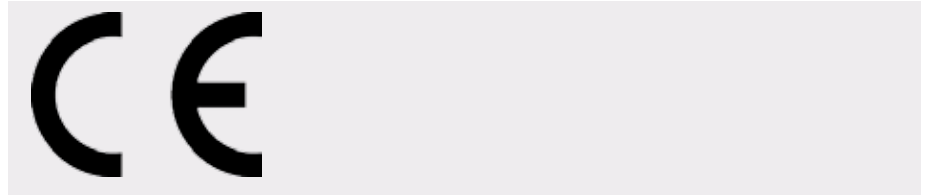

The CE-marking at USG Boral ME covers the mandatory properties Reaction to Fire and Emission of Formaldehyde and criteria such as Sound Absorption and Sound Attenuation when relevant. All declared values have been tested and verified by independent and certified laboratories. Furthermore, our continuously audited Factory Production Control will always ensure that customers receive products that live up to the standards of the product performance declared on the CE marked label.

	Ceiling Tiles	Ceiling Grids	Ceiling System (tile + grid)
Mandatory to declare, tested in accordance with EN 13964	<ul style="list-style-type: none"> • Reaction to fire • Emission of formaldehyde 	<ul style="list-style-type: none"> • Reaction to fire 	<ul style="list-style-type: none"> • Reaction to fire • Emission of formaldehyde
If declared, then tested in accordance with EN 13964 is mandatory	<ul style="list-style-type: none"> • Sound absorption • Thermal conductivity • Flexural tensile strength • Durability (corrosion of metal tiles) • Shatter (only for brittle materials) 	<ul style="list-style-type: none"> • Load-bearing capacity • Durability (corrosion of metal grids) • And others... 	<ul style="list-style-type: none"> • Fire resistance • Sound insulation • Impact resistance
If declared, then tested in accordance with EN 13964 is recommended but not mandatory	<ul style="list-style-type: none"> • Light reflection • Color definition • Gloss definition 		

ACOUSTICAL CEILING SELECTOR

1. Size

600 x 600 mm, 600 x 1200 mm, 300 x 1200mm, 300 x 1500 mm or 300 x 1800 and 600 x 1800 mm

Size (mm)	Metric Measures (mm)	Imperial Measures (mm)
600 * 600	593 * 593	603 * 603
600 * 1200	593 * 1193	603 * 1213
300 * 1200	293 * 1193	297 * 1213
300 * 1500	293 * 1493	297 * 1517
600 * 1500	593 * 1493	603 * 1517
300 * 1800	293 * 1793	297 * 1821
600 * 1800	593 * 1793	603 * 1821

2. Edge Details

SQ Edge 15

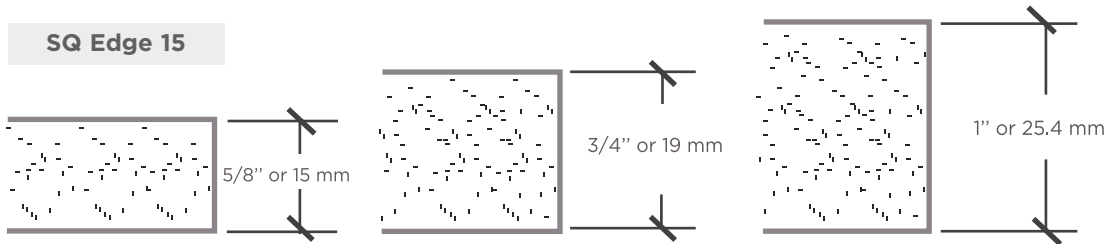

SLT Edge 15

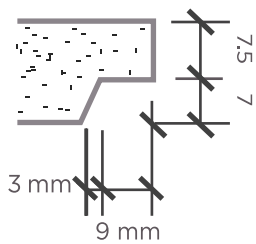

SL Edge 19

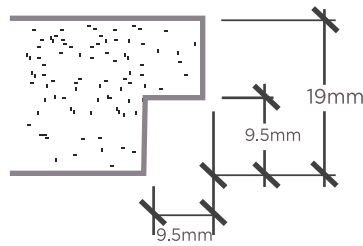

FL Edge 15

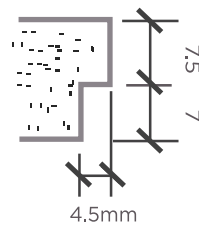

SLT Edge 19

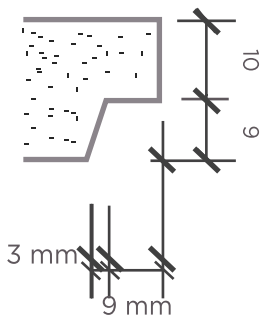

FL Edge 19

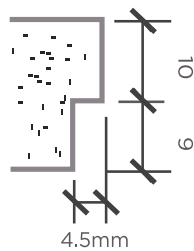

FLB Edge 19

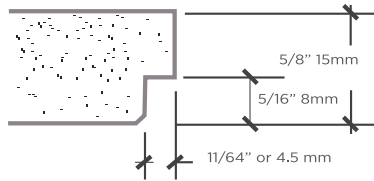
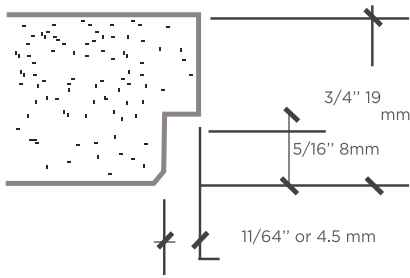

Concealed BESK Edge

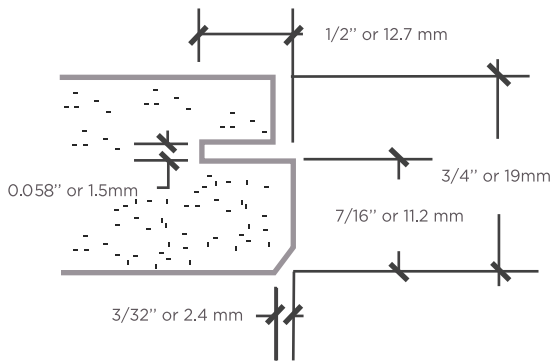

Pedestal Edge

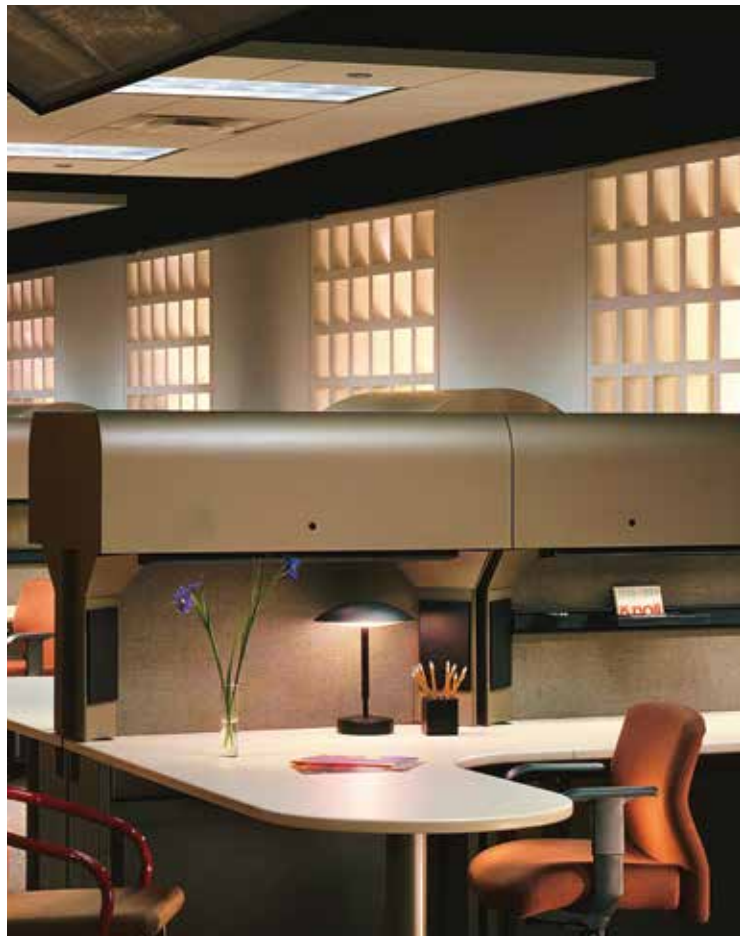
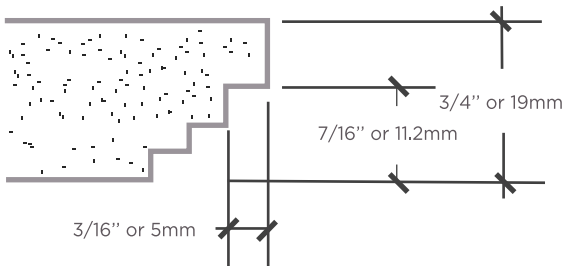

3. Light Reflectance

It is a measure of the percentage of light which is reflected off of a given panel surface. Typically, the whiter and the smoother the panel is, the higher LR value we have. Thus, this will:

- Enhance Indirect Lighting
- Reduce Energy Consumption
- Create Warm Luminous Aesthetics

ACOUSTICAL PERFORMANCE

Ceilings are excellent places for sound absorbing materials as well as additional fire and thermal insulation. We have ideal acoustic solutions for different kind of ceilings depends on room sort for interiors, hygienic spaces or industrial spaces.

A special room acoustic design is needed to create the suitable spaces for planned functions. There are basically two sound-related factors to be considered when designing a building:

- Choose quiet equipment (e.g. elevators, pumps, heating and ventilation equipment, etc.).
- Handle the sound in building by means of room acoustics and sound insulation.

It is important not to confuse the terms 'sound insulation' and 'sound absorption'.

Reflection, sound absorption and sound insulation

Sound may be absorbed, transmitted or reflected. When a room boundary, such as a roof, floor or a wall, is hit by a sound wave, some of the sound energy will be reflected, some is absorbed within the material and some is transmitted through it, as illustrated by the figure.

The proportion which is reflected, absorbed or transmitted depends on the shape of the material or the construction hit by the sound wave, and the frequency of the sound. Based on this, three acoustical parameters can be defined.

- Absorption coefficient, $\alpha_w = (\text{absorbed sound} + \text{transmitted sound}) / (\text{incident sound})$
- Reflection coefficient, $\alpha_R = (\text{reflected sound}) / (\text{incident sound})$
- Transmission coefficient, $\alpha_T = (\text{transmitted sound}) / (\text{incident sound})$

The Sound Absorption Coefficient can be measured by two very different methods - the room method and the tube method. The room method is normally used for presenting product information (as in this catalogue) and as input to calculation models. The measuring method follows an international standard designated EN ISO 354. The corresponding American standard is ASTM C 423 (measurements according to this often show slightly higher figures). The measurements are done in a large room with a diffuse sound field, i.e. the sound has evenly distributed angles of incidence against the test surface.

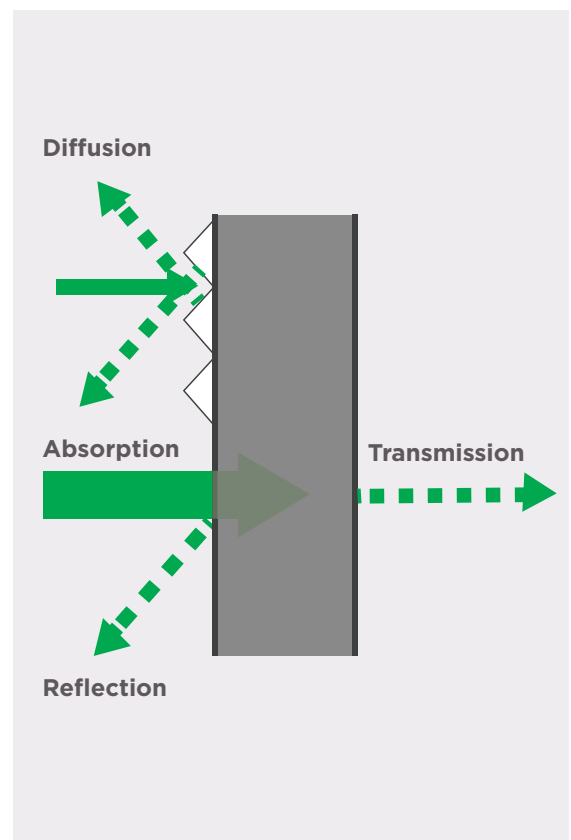

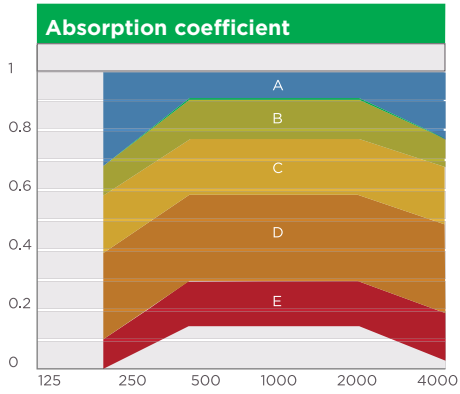

α_w	Sound Absorption Class
1.00-0.95-0.90	A
0.85-0.80	B
0.75-0.70-0.65-0.60	C
0.55-0.50-0.45-0.40- 0.35-0.30	D
0.25-0.20-0.15	E
0.10-0.05-0.00	Not classified

EN ISO 11654 is also used to classify the Sound Absorption materials based on the measured absorption curves to categories from A to E. Class A has the best ability to absorb sound, and E has the weakest. The installation method together with material properties have a great impact on the results. This classification system helps designers to compare and select the suitable absorption material(s) for different purposes.

α_w (Weighted Sound Absorption Coefficient) commonly used in Europe and it is the method which has been adopted as the norm for CE marking of suspended ceilings. It takes wide frequency based range of Sound Absorption coefficient values into a single number done using a curve fitting process.

The ASTM standard C423 specifies the NRC (Noise Reduction Coefficient) which is calculated as an average over the frequency ranges (250-2000 Hz) and centered at 250, 500, 1000 & 2000 Hz, rounded to the nearest 0.05.

The CAC (Ceiling Attenuation Class) is also a Single value for sound attenuation of a suspended ceiling between two rooms according to ASTM E 1414. This measurement takes only into account the sound transmission through the suspended ceiling.

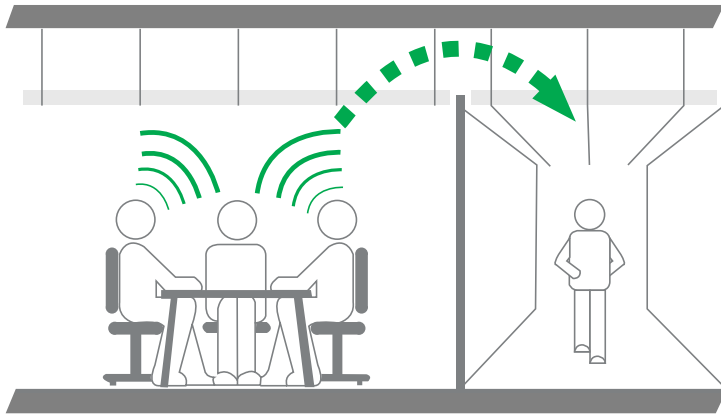

Room to room sound transmission through the ceiling



Open Plan Office Articulation Class beyond a barrier

ACOUSTICAL PERFORMANCE

In addition to reducing/increasing the sound level that occurs over distance, an absorbent ceiling will improve the function of screens and other screening furnishings. The degree to which a ceiling improves the effect of screens can be classified in an AC value (Articulation Class). Articulation Class (AC) is a single numerical rating used to identify the degree of transmitted speech intelligibility between office spaces. This rating is particularly useful for open plan offices. It is determined in accordance with ASTM E-1110. The higher the AC the better is the speech privacy in an open plan situation. For an office ceiling, the AC value should be at least 180. The derived value is a combination of the sound reflection /sound absorption characteristics of the acoustical product being tested in a prescribed assembly.

Good acoustics cannot be achieved by optimizing one single parameter. It's a set of factors which need to be aligned to the purpose of the room. Most regulations and guidelines refer to 3 key aspects:

1. Sound pressure level:

The human ear responds to sound pressure, which is measured in units of Pa (N/m²). The lowest sound pressure that an average ear can detect is about 0.00002 Pa, and the limit for pain is about 200 Pa. The experience of sound depends on

- The sound level
- The frequency
- The type of sound, if it is constant or intermittent
- If it is noise or nice music

2. Reverberation time:

How much echo is in the room?

The reverberation time of a room characterizes how long acoustic energy remains in it. It is usually defined as the time for the acoustic intensity to decrease by a factor of one million (60 dB).

The Sound absorption is directly related to reverberation time: in a small room or hall (volume <1000 m³) the empirical formula called the Sabine formula can be used to calculate the reverberation time. Absorption area of the room A is the sum of each surface area S multiplied by its absorption coefficient α_w . For example, if the desired reverberation time in a classroom is 0.8 seconds and the dimensions of the classroom are 6 x 10 x 3 m and the intention is to use 45 m² of absorbing ceiling material, what then is the required absorption coefficient for the product?

Answer: $A = 0.16 \times V/T = \alpha_w \cdot 0.5 = 0.16 \times 180/0.8 = 36\text{m}^2$
 $\alpha_w = 36/45 = 0.8$

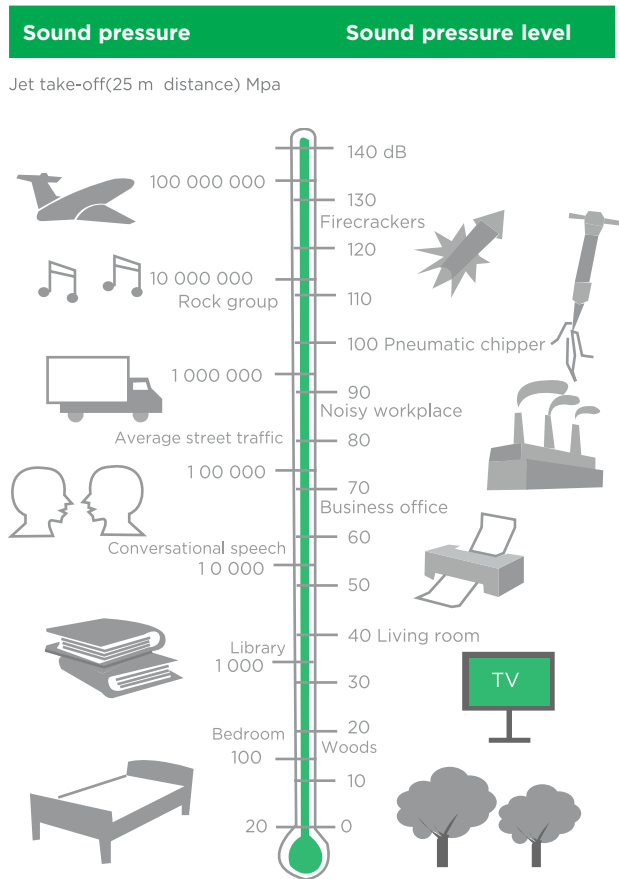

Sabine Formula for Reservation Time:	
T = 0.16 x (V/A)	
Where:	T = reverberation time, s V = volume of the space, m ³ A = total room absorption = $\alpha_w \cdot S \cdot m^2$
Where:	S = surface area of material α_w = sound absorption coefficient

It is generally agreed that acceptable reverberation times should be < 0.4 s for an all inclusive classroom and < 0.5 s for an open plan office. Reverberation time is dependent on the size and shape of the space and the amount, quality, and positioning of absorbing surfaces within the space. The more sound absorption in the room, the lower the reverberation time will be.

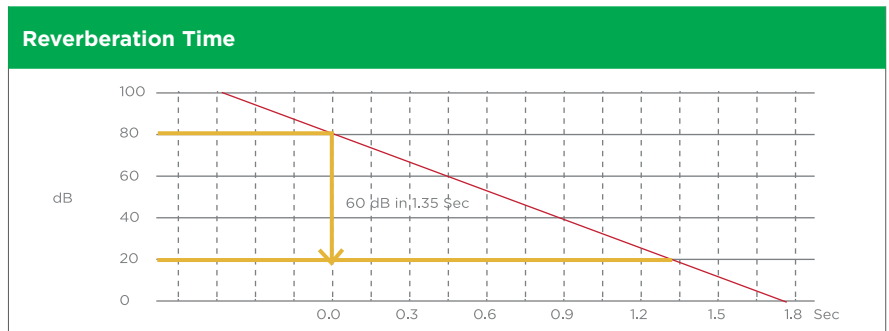

3. Materials & Room Acoustic Design:

Rooms with reasonable amounts of sound absorptive finishes appear quieter and less frenetic than those with little or no sound absorptive treatment. Materials that provide high levels of sound absorption are generally lightweight, porous & thicker which is the direct opposite of the qualities required for sound reduction i.e. massive and impervious

OCTAVE BAND	125	250	500	1000	2000	4000
Concrete	0.02	0.02	0.02	0.02	0.03	0.04
Gypsum board on stud	0.2	0.15	0.1	0.08	0.05	0.05
Windows	0.35	0.25	0.18	0.12	0.07	0.04
50-mm mineral wool slab*	0.2	0.65	1.0	1.0	1.0	1.0
100-mm mineral wool slab*	0.45	0.9	1.0	1.0	1.0	1.0

*with solid backing

- The optimum reverberation time for a space depends on the size, materials and type of room. Every object placed within the enclosure can also affect this reverberation time, including people and their belongings.
- Rooms for speech require a shorter reverberation time than for music. A longer reverberation time can make it difficult to understand speech. If, on the other hand, the reverberation time is too short, tonal balance and loudness may suffer.
- In industrial halls with a volume exceeding approximately 1000 m³, the height is normally much less than both the length and the width of the hall. In this case, the height and the furnishing density have a considerable influence on the sound field. In such a hall, the sound field is generally not diffuse and it is therefore not useful to calculate the reverberation time by using the Sabine formula

Remark:

In case of repainting of USG Boral ME Mineral Fiber and in terms of sound absorption there will be a small loss, depending upon the tile face pattern (fissures, perforations, scrim etc), the paint type used, and the thickness of the applied coat(s). It is unlikely that the ceiling's sound reduction or attenuation performance will be adversely affected but if the spaces where the ceiling has to be repainted are acoustically critical, then laboratory testing to assess any possible differences in acoustic performance should be conducted on repainted samples.

It should be noted that the repainting of ceiling tiles could also adversely affect their other technical performance factors such as Fire Reaction, Sag, Light Reflectance ... and the implication of such possible changes needs to be considered. Finally it should be appreciated that the repainting of any tiles supplied by USG Boral ME will invalidate any warranty that was provided when the tiles were new.

FIRE SAFETY FOR CEILING



FIRE REACTION

A fire is always a result of an ignition source (heat), oxygen (air) and the presence of a combustible material.

The ignition source is mostly caused by human acts, conscious or by accident. Oxygen is needed to keep the fire going. It is obvious that without combustible material a fire is impossible. To contribute to the prevention of the devastating effects of fires, two regulations apply to construction materials:

Reaction to fire: determines whether a material fuels a fire.

Fire resistance: indicates how well a building element (or a system) - for a stated period of time - can hold back fire and prevent it from penetrating from one room to another.

1. The European system

Reaction to fire - Euroclass

The reaction to fire testing and classification system for linings and materials in Europe is called Euroclass.

Euro class fire test methods:

- Non-combustibility test EN ISO 1182
- Gross calorific potential test EN ISO 1716
- Single Burning Item test EN 13823
- Ignitability test EN ISO 11925-2

These test methods are referred to as “reaction to fire” tests and the purpose is to evaluate the contribution of products and materials to the early stages of a fire in terms of:

- Ignitability
- Flame spread
- Heat release
- Smoke production
- Occurrence of flaming droplets/particles

A material reaction to fire is defined by Euro classes A1 to F. Classification is based on the tendency of a material to avoid flashover or promote flashover. Flashover determination is based according to above Euro Class fire test methods. Non-combustible materials and products (A1 and A2) will not cause flashover. USG Boral ME Mineral Fiber products are classified in Euro class A2- s1, d0 (as per EN ISO 13501-1 classification), which means that they do not contribute to fire.

<u>A2-</u>	<u>s1,</u>	<u>d0</u>
1	2	3

1. Main class
2. Smoke production
3. Occurrence of flaming droplets/particles

Euro Class	Example	Smoke, Index	Burning Dropets, Index
A1,A2	Stone wool, Mineral Wool, Gypsum board	s1 (least smoke)	d0 (no burning droplets)
B	Painted gypsum board	s2	d1
C	Gypsum board with wallpaper	s3	d2
D	Wood		
E	Fire-retardant EPS		
F	Non-tested materials, EPS		

2. The ASTM system

Reaction to fire

In the US market products are tested and classified according to ASTM standards (American Society for Testing and Materials). Flame spread and smoke production on ceilings, are tested and evaluated according to ASTM E 84 "Surface Burning Characteristics of Building Materials". A smoke production index and flame spread index is then derived from the measurements that are taken. Acoustic ceiling products are classified according to ASTM E 1264. Three fire classes are defined;

A (the best), B and C. The classes are equivalent to classes I, II and III, respectively, of various building code authorities. All USG Boral ME Acoustical Ceiling panels are of Class A. In addition for class A, USG Boral ME acoustical Ceiling products do not show evidence of continuous progressive combustion after the test flame has been extinguished.

MAX ALLOWED INDEX Class	Flame Spread	Smoke Development
A	25	50
B	75	-
C	200	-

FIRE RESISTANCE

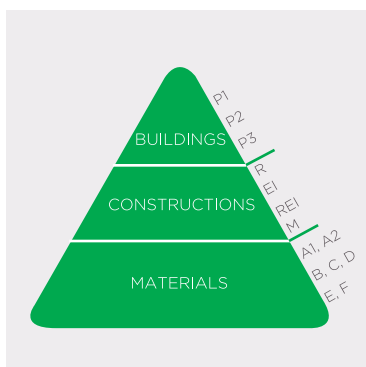

1. The European system

A performance benefit of choosing a suspended ceiling over an open plenum ceiling is an added extra margin of fire safety. The ceiling represents a significant percentage of a room's surfaces, and is critical to controlling the growth of a fire within a room or space.

The Fire Classification as per National Building Codes is not only related to the material type, but it involves the Fire Resistance for the construction system based on the building type, size, fire load and occupancy.

Whereas products are classified using their reaction-to-fire behavior, **ROOFS, WALLS, FLOORS, CEILINGS** and also the building systems including air ducts and pipes are classified based on their fire resistance behavior.

The main classes used for the fire resistance classification of building elements are:

R = Load bearing capacity

E = Integrity (ability to prevent leakage of flames and hot gases)

I = Insulation (ability to reduce the heat transfer)

FIRE SAFETY FOR CEILING

The classes are always combined with a time class expressed in minutes. These time classes could be from 15 up to 360 minutes in steps defined in the classification standard EN 13501-2. A separating and load bearing wall could for example be classified as REI 60, which means that it will retain its load bearing capacity as well as its fire separating function during 60 minutes of a fully developed fire. A non-load bearing element will only be given the classification EI or E combined with a time class. The latter case is for example relevant for special fire glazed partitions which will prevent the penetration of flames and hot gases but not provide insulation against heat. A load bearing column, which is obviously not a separating element, can accordingly, only have the fire resistance class R combined with a time class.

R	E	I	60
1	2	3	4

- 1 = Load bearing capacity
- 2 = Integrity (ability to prevent leakage of flames and hot gases)
- 3 = Insulation (ability to reduce the heat transfer)
- 4 = Time class in minutes

2. The ASTM system

Fire separating elements, such as fire walls and floor structures, are tested and evaluated in accordance with ASTM E 119 "Fire Tests of Building Construction and Materials". ASTM E119 is an assembly test, not a product test carried out in full scale. This is the test method (UL) use for fire resistance rated assemblies. The test specimens are subjected to a heat exposure that corresponds to a fully developed fire. A UL fire resistant rated ceiling assembly provides a known, specified fire resistance period.

The Fire-Resistance Rating of a Ceiling Assembly (ANSI/UL 263 - ASTM E119 and NFPA 251) represents the degree to which (measured in hours) the entire assembly, not individual components, withstands fire and high temperatures. Specifically, it is an assembly's ability to prevent the spread of fire between spaces while retaining structural integrity.

Two types of fire-rated construction assemblies pertain to acoustical ceiling systems:

Roof/Ceiling Assemblies:

Ceiling system, lighting, HVAC outlets and other penetrants through the ceiling, the plenum, roof support structure and roof assembly including deck, insulation and roofing system.

Floor/Ceiling Assemblies:

Ceiling system, lighting, HVAC outlets and other penetrants through the ceiling, the plenum, structural system, subfloor and finish floor

The Floor could be:

Concrete Floor, Wood Deck and Mezzanine

Only Fire Code ceilings and Grid Types can be used in fire-rated assemblies. Individual components, such as ceiling panels or suspended grid systems, are not assigned fire resistance ratings. You can use only the specific type, size and minimum thickness of Fire Chief Ceilings or grid identified in each assembly.

The Fire Chief Ceilings are specially formulated in a variety of textures to provide enhanced resistance against structural failure. The DXL Suspension Systems have patented expansion reliefs, to help maintain structural integrity of the ceiling.

Remark:

To select the correct UL fire-rated assembly, please refer to www.usgdesignstudio.com by:

- Establish the hourly rating needed to meet code requirements.
- Determine the existing or planned building elements, including structural, mechanical, electrical and finish materials, in the fire-rated assembly
- Determine which UL design numbers resemble your building
- Submit the chosen UL design to the code official for approval

ENVIRONMENTAL STATEMENT



ENVIRONMENTAL STATEMENT

Recycling is only a part of the story. Careful production methods are good for the environment and increase efficiency. Our practices include:

- Using clean fuels (NG)
- Treating and recycling water (Saving of 300 m³ daily at USG Boral ME)
- Reducing waste (Recycling): Waste from the production line and panels chipped or broken during processing are returned to the manufacturing cycle, keeping them out of landfills
- Offering specialized ceiling panels: High-durability acoustical panels extend the useful life of ceilings and reduce operating and replacement costs. Panels with high light reflectance can enhance indirect lighting, reducing the number of light fixtures needed and lowering energy consumption
- Recycling old ceiling panels
- Product life cycle: USG Boral ME's commitment to health, safety and environmental responsibility is evident at every stage in the life cycle chain.

USG Boral ME has been granted to ISO 14000 certificate. This indicates that environmental aspects such as emissions into the air, waste handling, utilization of natural resources and energy efficiency are paid attention to at USG Boral ME and the environmental impacts of production are constantly improved. In addition to ISO 14000 certification, USG Boral ME is working to prove the environmental profile of USG Boral ME products by acquiring EPD (Environmental Product Declaration) to its Ceiling family range.

GREEN FACTS:

- More than 70% of manufacturing waste is recycled into ceiling products
- The majority of the Ceilings product offering contains 50% recycled content or higher
- USG Boral ME mineral fiber ceiling panels incorporate steel mill slag waste as well as post-consumer waste such as newspapers
- USG Boral ME has an Environmental certificate for its facility in Dammam for compliance with PME (Presidency of Metrology and Environment) according to Local regulations
- All USG Boral ME panels feature low VOC emission and comply with the Collaborative for High Performance Schools (CHPS) standards
- Many USG Boral ME ceiling products reflect light and work well in architectural designs that promote day lighting; reductions in lighting density made possible by such designs can result in energy savings and greenhouse gas reduction

USG BORAL ME & SUSTAINABILITY

CERTIFIED BUILDINGS

The Green Building certification systems are becoming important tools to encourage and reward social and environmental responsibility and over the last decade, there has been a rapid increase in the number of assessment methods, tools, labels and certificates. The Green Building systems are tools that encourage sustainable design and the use of local materials in the construction, operation and maintenance of buildings. Furthermore, specific requirements have been developed in order to protect the health and well-being of the building occupants.

System	Year Established	Country of Origin	Certified Levels
BREEAM	1990	UK	Pass, Good, Very Good, Excellent, Outstanding
LEED	1998	USA	Certified, Silver, Gold, Platinum
HQE	2005	France	High, Performing, Very Performing
DGNB	2008	Germany	Bronze, Silver, Gold

Here is a brief overview of the most common rating tools: Whether you are looking to make a more sustainable building or even have it certified through BREEAM, HQE, DGNB, LEED or another program, USG Boral ME products can help you achieve your goals. It is no longer enough for buildings to be simply “green”. In today’s world, buildings need to go beyond being simply “green” and become sustainable.

They should contribute to improving social and economic issues such as health, wellbeing, efficiency and life cycle costs. One of the most widely used systems for Green Building Ratings is LEED

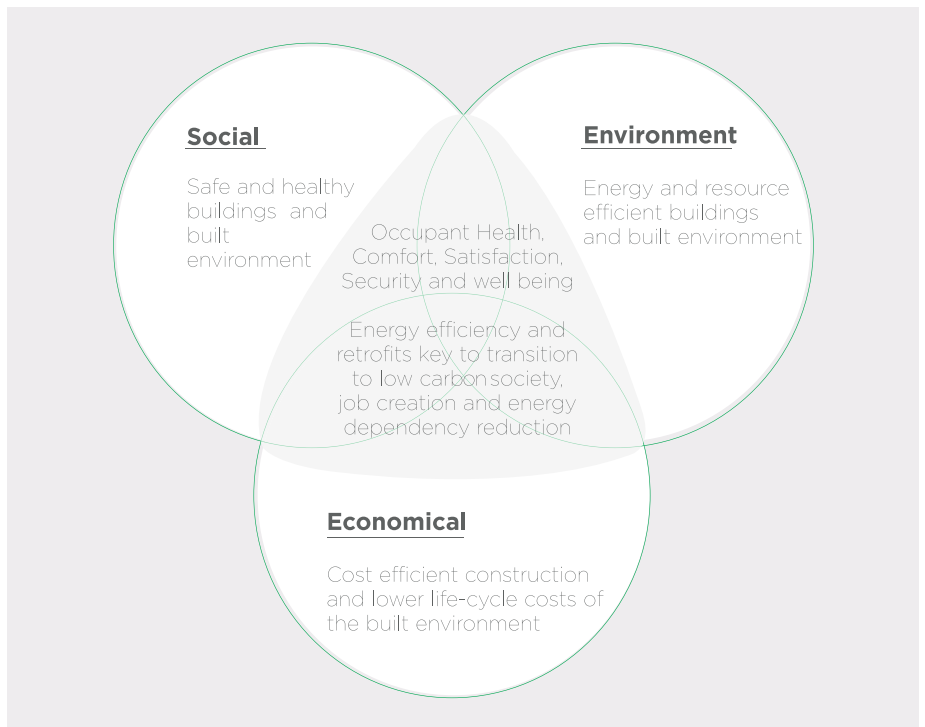

LEED LEADERSHIP IN ENERGY AND ENVIRONMENTAL DESIGN

LEED® is a guideline for building solutions established by the USGBC-Products or Companies are NOT “LEED certified”, however they can assist in obtaining LEED credit/points for a project. LEED certification provides independent, third-party verification that a building, home or community was designed and built using strategies aimed at achieving high performance in Five key areas of human and environmental health:

- Sustainable Site development
- Water Savings
- Energy Efficiency
- Materials Selection
- Indoor Environmental Quality

LEED provides building owners and operators with a framework for identifying and implementing practical and measurable green building design, construction, operations and maintenance solutions. LEED requirements vary according to the use of the buildings:

- LEED for New Constructions and Major renovations (NC)
- LEED for Schools - New Constructions and Major renovations (Schools)
- LEED for Core and Shell Development (CSD)
- LEED for Commercial Interiors (CI)

As a member of the U.S. Green Building Council (USGBC), USG Boral ME Ceilings is a leader in the effort to provide acoustical ceiling solutions that promote sustainable design. USG Boral ME Ceilings contribute actively to sustainability by creating a comfortable acoustic environment, helping increase user productivity and wellbeing, and being highly durable. USG Boral ME Ceilings’ manufacturing processes incorporate sustainable design criteria—from the product’s raw material content to how it’s handled through manufacturing and shipping, as well as through the product life cycle.

LEED-NC, LEED-CS, LEED FOR SCHOOLS, LEED FOR HEALTHCARE AND LEED FOR RETAIL

(LEED for NC, CS, Schools, LEED for Canada: NC : LEED 2009 LEED for Healthcare: Healthcare Supplement LEED for Retail Supplement 2009)

Credits	Description	Possible Points				
		NC	CS	Schools	Healthcare	Retail
Energy & Atmosphere						
EA Prereq.2	Minimum Energy Performance	Req	Req	Req	Req	Req
EA1	Optimize Energy Performance	1-19	3-21	1-19	1-24	1-19
Materials & Resources						
MR 2	Construction Waste Management	1-2	1-2	1-2	1-2	1-2
MR3	Sustainably Sourced Materials & products	NA	NA	NA	1-4	NA
MR4	Recycled Content	1-2	1-2	1-2	NA	1-2
MR5	Regional Materials	1-2	1-2	1-2	NA	1-2
MR6	Rapidly Renewable Materials	1	NA	1	NA	1
Indoor Environment Quality						
IEQ2	Acoustic Environment	NA	NA	NA	1-2	NA
IEQ prereq.3	Minimum Acoustical	NA	NA	Req	NA	NA
IEQ4	Performance	NA	NA	NA	1-4	1-4
IEQ4.6	Low-Emitting Materials	NA	NA	1	NA	NA
IEQ8.1	Low-Emitting Materials-Ceiling and Wall System	1	1	1-3	2	1
IEQ9	Daylight & Views-Daylight Enhanced Acoustical Performance	NA	NA	NA	NA	NA

USG BORAL ME & SUSTAINABILITY

Recycled Content

USG Boral ME acoustical ceiling panels contain mineral wool derived from slag, a byproduct of steelmaking, reducing the need to mine and process raw materials and minimizing landfill waste. Many panels also contain recycled paper. Binders are derived from corn and wheat starch, which are renewable agricultural resources. The metal in many of our metal and specialty ceiling and drywall suspension systems includes recycled content. Aluminum offers additional benefits in that it can be fully re-purposed by re-melting and salvaging the metal.

USG Boral ME ceilings = High Recycled Content (HRC)

The Total Recycled Content includes Post-Consumer & Post-Industrial materials:

(Post-Consumer & Post-Industrial)

Per Federal Trade Commission Environmental Marketing Guides. Recycled Content products may contain some pre-consumer waste, some post-consumer waste or both. A product does not have to contain 100 percent recovered materials to be considered “recycled,” but the higher the percentage of recycled content, the greater the amount of waste that is diverted from disposal.

We use Weighted Recycled Content to refer to the value defined for LEED MR4 as Post-Consumer content + 1/2 Pre-Consumer (Post-Industrial) content.

- Post-Industrial (Pre-Consumer)

Materials are generated by manufacturers and processors, and may consist of scrap, trimmings and other by-products that were never used in the consumer market. Post-Industrial and Pre-Consumer are one in the same under the USGBC LEED® rating systems.

- Post-Consumer

Material is an end product that has completed its life cycle as a consumer item and would otherwise have been disposed of as a solid waste. Post-consumer materials include recyclables collected in commercial and residential recycling programs, such as office paper, cardboard, aluminum cans, plastics and metals.

- TVOC (Total Volatile Organic Compound) emission measured per ASTM D 5116, State of Washington allows for 500 ug/m³ (50 ppb).

- CHPS (Collaborative for High Performance Schools) follow EPA Section 01350 for VOC emission and determination on PASS.

- Formaldehyde

Emissions measured during CHPS testing per Section 01350, for most products CHPS allows 13.5 ppb (Formaldehyde concentration 9 µg/m³).

- LR (Light Reflectance) tested per ASTM C1477
- NRC (Noise Reduction Coefficient) tested per ASTM C423
- CAC (Ceiling Attenuation Class) tested per ASTM 1414
- Zero emissions

Is defined as the quantity less than test chamber background concentrations as required by Section 3.8.4.2 of the “Standard Practice for the Testing of Volatile Organic Emissions from Various Sources Using Small-Scale Environmental Chambers, Supersedes previous versions of small-scale environmental chamber testing portion of California Specification 01350, July 15, 2004.” Section 3.8.4.3 states “ Background concentrations in the empty chamber ventilated at 1.0 air changes per hour shall not exceed 2 g/m³ for any individual VOC, and 25 g/m³ for TVOC.”

RELATED USGBC LEED for NC Credits

PRODUCT FAMILY

Fissured Family ⁴
Plain Family ⁵
Olympia Micro™ ClimaPlus™
Perforated / Athena
Taiga Hygiene
Sparta
Sonata/Sonata HC
Clean Room™
Metal Face
Radar™ Ceramic
Halcyon™/Halcyon HC
Louna
Louna HI CAC
Glacier™
Frost™
Sandrift™
Mars™ ClimaPlus™
Mars™ ClimaPlus™ High NRC
Mars™ ClimaPlus™ HealthCare
Millenia™ ClimaPlus™
Eclipse™ ClimaPlus™
Astro® ClimaPlus™
Skyrock Nordic / Classic
Wood Tone
DONN® Brand Hot Dip Galvanized Steel Suspension System
USG Boral ME Metal Ceiling

MR 4.1 & 4.2				EA 1 & EQ 8	EQ Pre 3' & EQ 9'					EQ 3.2 & EQ 4	MR6	EQ 10'
Post Consumer		Pre-Consumer		LR	NRC	CAC	Density KG/m ³		VOC Content or CHPS	Formaldehyde & VOC Emissions	Rapid Renew	Mold Prevention
Class A	FC	Class A	FC				Class A	FC				
20.0%	6%	12%	40.0%	0.84-0.87	0.5 ² /0.6 ³ /0.7 ⁸ /0.8 ⁹	35-39	240	320	Pass	Low	7.5%	*
20.0%	N/A	12%	N/A	0.88-0.89	0.15	31-35	240	N/A	Pass	Low	8.0%	*
17.0%	6%	22%	40.0%	0.89	0.55 ² /0.65 ³ /0.7 ⁸	35-39	240	320	Pass	Low	7.5%	*
20.0%	N/A	12%	N/A	0.88	0.5 ² /0.7 ⁸	35-37	240	N/A	Pass	Low	8.0%	*
20.0%	N/A	12%	N/A	0.88	0.15	31-35	240	N/A	Pass	Low	8.0%	YES
20.0%	N/A	12%	N/A	0.85	0.15	36	240	N/A	No	Zero	8.0%	N/A
2.5%	N/A	80%	N/A	0.88	0.75	37-40	240	N/A	Pass	Low	7.5%	YES
N/A	6%	N/A	40.0%	0.79	0.15/0.55	37	N/A	320	No	N/A	7.0%	N/A
N/A	6%	N/A	40.0%	0.79	0.55	37	N/A	320	No	N/A	7.0%	N/A
N/A	0.0%	N/A	45.0%	0.85	0.4	39	N/A	550	Pass/Zero	Low	2.5%	N/A
39.0%	N/A	1%	N/A	0.88	0.85 ² /0.95 ³ /1 ⁶	24-25	72	N/A	No	N/A	0.0%	N/A
39.0%	N/A	1%	N/A	0.84	0.85 ² /0.95 ³ /1 ⁶	24-26	90	N/A	No	N/A	0.0%	N/A
45.0%	N/A	41%	N/A	0.84	0.85	42	280	N/A	No	N/A	7.0%	N/A
0%	0%	71%	71%	0.7	0.65	35	375	390	Pass/Zero	Zero	12.5%	N/A
0%	0%	71%	71%	0.85	0.55 - 0.7	36-40	425	440	Pass/Zero	Zero	12.5%	N/A
0%	0%	71%	71%	0.83	0.55 - 0.7	38	425	440	Pass/Zero	Zero	12.5%	N/A
0%	N/A	75.2%	N/A	0.89	0.7	35	260	N/A	Pass	Low	3%	YES
0%	N/A	77%	N/A	0.89	0.8	35	260	N/A	Pass	Low	3%	YES
0%	N/A	77%	N/A	0.89	0.7 - 0.8	35	260	N/A	Pass	Low	3%	YES
0%	N/A	75%	N/A	0.87	0.7 - 0.75	35	275	N/A	Pass	Low	1-3.5%	YES
0%	0%	77%	62%	0.86	0.6 - 0.7	35	250	310	Pass	Low	1-3%	YES
0%	0%	65%	68%	0.86	0.5 - 0.55	35	220	285	Pass	Low	3.5%	YES
				0.85	0.85 - 1				Pass	Low		
				0.88	0.15	37	280		No	Zero	8%	
25 to 50%	N/A	6 to 8%	N/A									*
68%	N/A	22%	N/A		0.65							

LEGEND: 1- For Schools Credit only 2- For 15mm 3- For 19mm 4- Fissured Family include the following patterns: · Cross Fissured · Omni · Radar™ · Favia (Europa) · Favia Acoustic · Plateau™ (Aurora) · Face Cut 5- Plain Family include the following patterns: · Taiga™ · Olympia II™ · Comet Line · Chessboard · Pedestal · Face Cut 6 - For 25mm 7- MR Credit 7 compliance: Certified Wood 8- For 19mm High NRC Products 9 - For 22mm High NRC Products
* - Available upon request

SUSTAINABILITY

The Brundtland commission defined sustainability in 1987 as “Development that meets the needs of the present without compromising the ability of future generations to meet their own needs.”

In line with current understanding, this definition contains environmental, social and economic aspects of human activities in a global context.

Environmental aspects would include, for example, efficiency of use of primary and other resources, pollution, waste and recycling. Social aspects concern, for example, the well-being of employees, health and safety, contributions to society at large, corporate citizenship and the long-term viability of business. The economic aspects are exemplified by profitability, efficiency, stakeholder added value and ROI.

Requirements for sustainable building are:

- Efficient use of energy
- Minimization of emissions
- Utilization of production waste and recycling
- Ascertaining the service life
- Flexibility

Sustainable consumption means that resource efficiency will continue to be a main driver in developing our operations. The outcome for our customers is less embodied energy and ground-, water- and air emissions in our products – and a cleaner and healthier environment.

MR 5.1/5.2	
Raw Materials (% by wt.) / Percent Compliance for Materials extracted, harvested, or recovered and manufactured locally	% Compliance
Wet Felt Products manufactured at Dammam, Saudi Arabia. Mineral Wool (Pre-consumer %) from China / USA; Perlite 20-50% (over 500 miles); Recycled Paper (Post - consumer %, Local); Starch (Rapid renewable%, local); and Clay (over 500 miles) 2 - 12%; Embodied Energy 14.6 MJ/Kg	26%/13%
	26.0%
	24%/13%
	26.0%
	26.0%
	26.0%
	11.5%
	13.0%
	13%
	2.5%
Glass Fiber Products manufactured at Dammam, Saudi Arabia. 90% Glass Fiber Base mat (local), 9% Glass Fiber Facing (over 500 miles), 1% Water Base Adhesive (over 500 miles) - Embodied Energy 30.3 MJ/Kg	65%
	65%
	65%
Cast Products manufactured at Walworth, WI, USA Mineral Wool (Pre-consumer %) made on site; Class A panels 10% Plaster of Paris from East Chicago, IN Starch (Rapid renewable%); and FC panels Clay 14%	0%
	0%
	0%
X-Technology manufactured at Cloquet, MN, USA Mineral Wool (Pre-consumer %) from Red Wing, MN; 5% Polymer Emulsion Starch (Rapid renewable%); and FC panels Clay 20%	0%
	0%
	0%
	0%
	0%
	26%
Manufactured at Dammam, Saudi Arabia.	N/A
Metal Sheets, Dammam, Saudi Arabia.	0%

MOLD PREVENTION

NO GROWTH OF MICRO-ORGANISMS

Excessive humidity and moisture in a building can promote the development of microorganisms such as mold or bacteria and cause allergic reactions, respiratory illness or skin problems.

USG Boral ME address the issue of mold and microbial growth by providing acoustical ceiling tiles treated with a USG Boral ME antimicrobial treatment that provides broad spectrum control for mold/mildew.

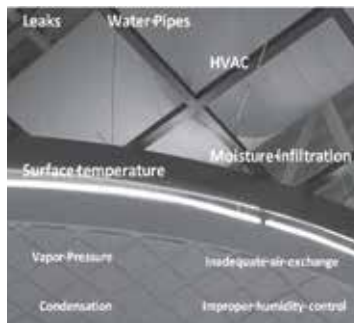

YOU CONTROL MOISTURE. WE HELP CONTROL MOLD

USG Boral ME's position on ASTM D3273 and ASTM C473

In the absence of specific tests for the broad category of construction products, the industry uses ASTM C473 and D3273. ASTM C473 measures water absorption of panels as a percentage of weight. ASTM D3273 measures resistance to mold growth on the surface of interior coatings rather than building materials. These test results do not represent definitive installed performance in specific project conditions. Products are being classified out of this test per ASTM D3274 where Rate 10 is designated for No Growth of Mold after 4 weeks Incubation. Special Products for HealthCare application like Taiga Hygiene & Sonata HC comes directly with Mold Prevention application per ASTM D3273.

USG Boral ME is actively working with academic and industry testing leaders to develop a new test method with conditions that more closely approximate real-life conditions.

PRODUCTS ALONE CANNOT CONTROL MOISTURE OR PREVENT MOLD

All products become susceptible to mold growth under unfavorable conditions. The EPA has found that mold will grow even on stainless steel, glass and all surfaces, given the right conditions.

In addition to mold growth, it is now important to install products that have low impact on Indoor Air Quality on other term on Comfort and Health.

ENVIRONMENTAL AIR QUALITY

HEALTH AND COMFORT

People spend about 90% of their time indoors. Therefore, from the viewpoint of health, the quality of indoor air is even more important than outdoor air. A good indoor climate reduces the number of illnesses & sick building syndrome symptoms, & improves occupants comfort & productivity.

A good Indoor climate is therefore one of the most important goals of design and construction.



INDOOR AIR QUALITY

The Indoor Air Quality is affected equally by heating, ventilation and air conditioning, construction engineering, the quality of construction work, building materials as well as the operation and maintenance of the building. USG Boral ME Ceiling panels do not contain asbestos, carcinogens, mutagens or substances toxic to reproduction. It is important to identify the indoor-related time value, which is the time it takes from the installation of a product until the emission of ammonia, formaldehyde, VOC (Volatile Organic Compounds) and particles to decay below specified levels. This is based on odour and mucus irritation thresholds for eyes and the upper respiratory passage as well as standard room considerations. USG Boral ME products are classified to have low impact on indoor air quality. Even when installed in a fully furnished room with very little fresh air, the concentrations of VOCs & Formaldehyde are well below acceptable levels.

Clean Room Classification

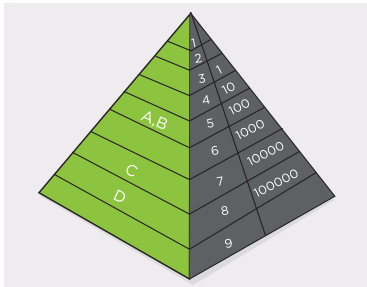

All USG Boral ME products are classified as E1 products which guarantee that the products are below the lowest EU requirement for Formaldehyde emission.

Many USG Boral ME ceiling panels help to support healthy environments with reduced Volatile Organic Compound (VOC) emissions: Ceiling with Little or No Formaldehyde Requirements as per CHPS (Collaborative For High Performance Schools)

- Zero VOC Emission for All CAST Ceilings (level < 2mg or 1.6 ppb)
- Low-Emitting Ceilings (level < 9 µg/m³)
- Meets minimum Standards (state of Washington Level < 50 ppb)

CLEANLINESS

The dust particles can also impact on the health of people and be critical in special industries in the pharmaceutical, electronics and food industries and in certain hospital environments.

The international EN ISO 14644-1 standard (classes 1 to 9) is used for the classification of air cleanliness. This is the official standard, but the US Federal standard 209E (classes 1 to 100 000) is also widely spread.

Clean Room™ Classification

FED STD 209D/209E		ISO 14644-1	Industry Application Areas		
English	Metric	ISO Class			
-	-	1			
-	-	2			
1	M1.5	3	Micro-electronics		
10	M2.5	4			
100	M3.5	5			
1,000	M4.5	6		Pharmaceutical	
10,000	M5.5	7			Electronics and Food
100,000	M6.5	8			Automotive and Space
-	-	9			

A selective number of USG Boral ME products are certified class ISO 5 meeting the requirement of demanding clean rooms in regard to particle emissions.

WATER SHIELD



In its continuous improvement, USG Boral ME offers an invention in mineral fiber ceiling tiles.

Normally, the ceiling tiles have a tendency to stain when in contact with water due to condensation on pipes and duct work above the ceiling. The condensate can drip into the backside of the ceiling tiles and migrate to the visible side of the tile.

The water droplets can leach tannin from recycled materials and other cellulosic based materials and staining agent from the paint surface of the tile.

USG Boral ME's new invention provides an economical solution to minimize water stains at the visible face of the panel. This invention creates a barrier to water droplets at the backside of the panel allowing the droplet to evaporate before it can migrate through the panel.

This treatment provides a Water Shield to mineral fiber tiles in a practical and cost effective way.

Sonata™ & Halcyon™ for HealthCare application features with Water repellent membrane on it's finished surface for more durable and safety with common disinfectant. It Exceeds FGI guidelines for healthcare applications and meets USDA/FSIS guidelines for use in food-processing areas. It Achieve FDA standards for being smooth, durable and easily cleanable- all of which can enhance the indoor environmental quality of your healthcare spaces.



THERMAL RESISTANCE

The Thermal Resistance is the resistance of a material or assembly to the flow of heat. For insulating purposes, high "R" values are the most desirable. The R-value as measured at an average temperature of 24°C(75°F) is listed for each panel. The R Value of our ceiling panels is a combination of Thermal Conductivity, measured according to norm EN12667 & ASTM C518 and the thickness of the material.

It is calculated as follows: $R = T / \lambda$, where λ is the Thermal Conductivity of a material and is expressed in m^2K/W and T Thickness in meter.

The thermal conductivity of our Mineral Fiber Materials wet felted is $\lambda = 0.064 W/mK$ and $0.034 W/mK$ for our Fiber Glass base materials. The smaller the λ -value, the better the thermal insulation of the material is.

The U value (Thermal Transmittance) is the reverse of R value (Thermal Resistance). However, U is usually done for a whole system to evaluate the heat loss and should not be taken for a single component.

So, USG Boral ME Ceiling is not only being seen for its Acoustical & Fire properties, it contributes in the total thermal insulation solution of the space taking into account building physics (e.g. condensation, avoiding thermal bridges, etc). The benefit of the intrinsic thermal insulation capacity of Slag Wool & Fiber Glass base material, as a major component of USG Boral ME ceiling tiles that it can be used efficiently when shopping malls are built over parking garages as well as in flat-roof buildings or in old buildings with cold cellars.

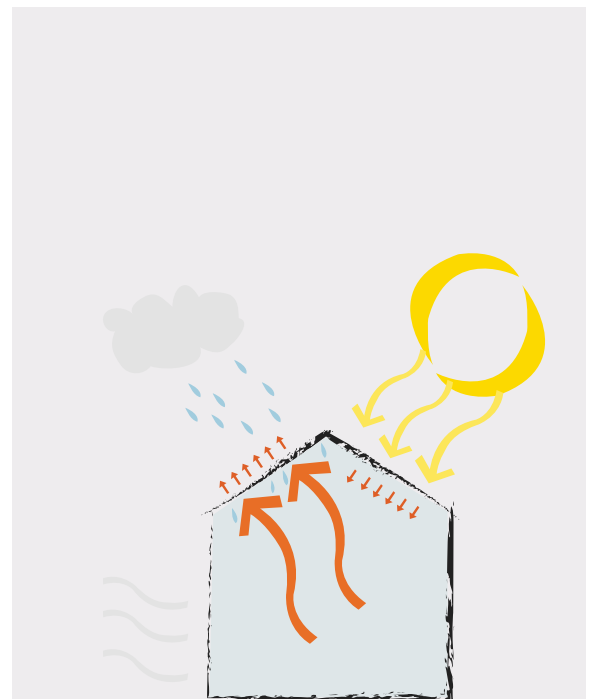
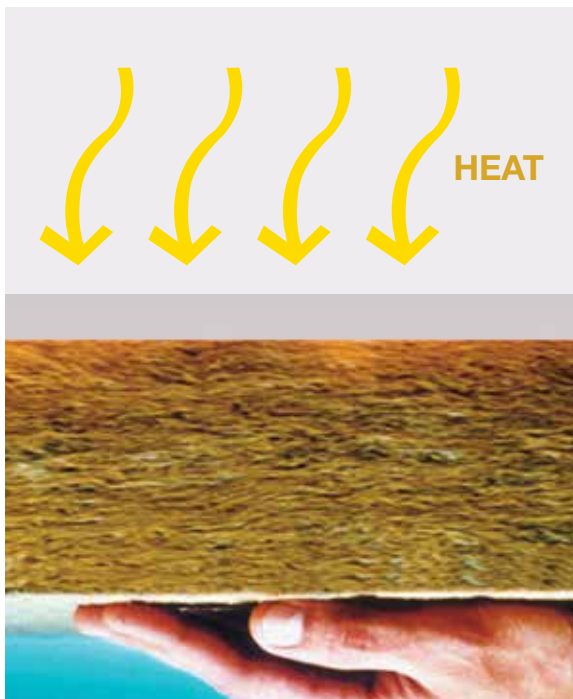



**ACOUSTICAL
CEILING
INSPIRED BY YOU**



ATHENA

STANDARD SPECIFICATION

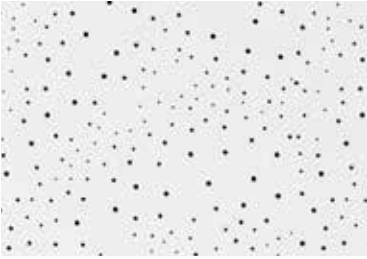

ATHENA SOUND ABSORPTION - 19 MM

Features & Benefits:

- Offered in Multiple Pin Perforation for Ideal Mid-range sound absorption & sound Attenuation which provides balance to room acoustics
- Excellent for general commercial construction & Health Care
- Maximum economy and design simplicity
- Could be available in Washable & Hygienic Paint upon request

Applications:

- Schools
- Healthcare
- Corridors
- Lobby areas
- Offices
- Retail Stores

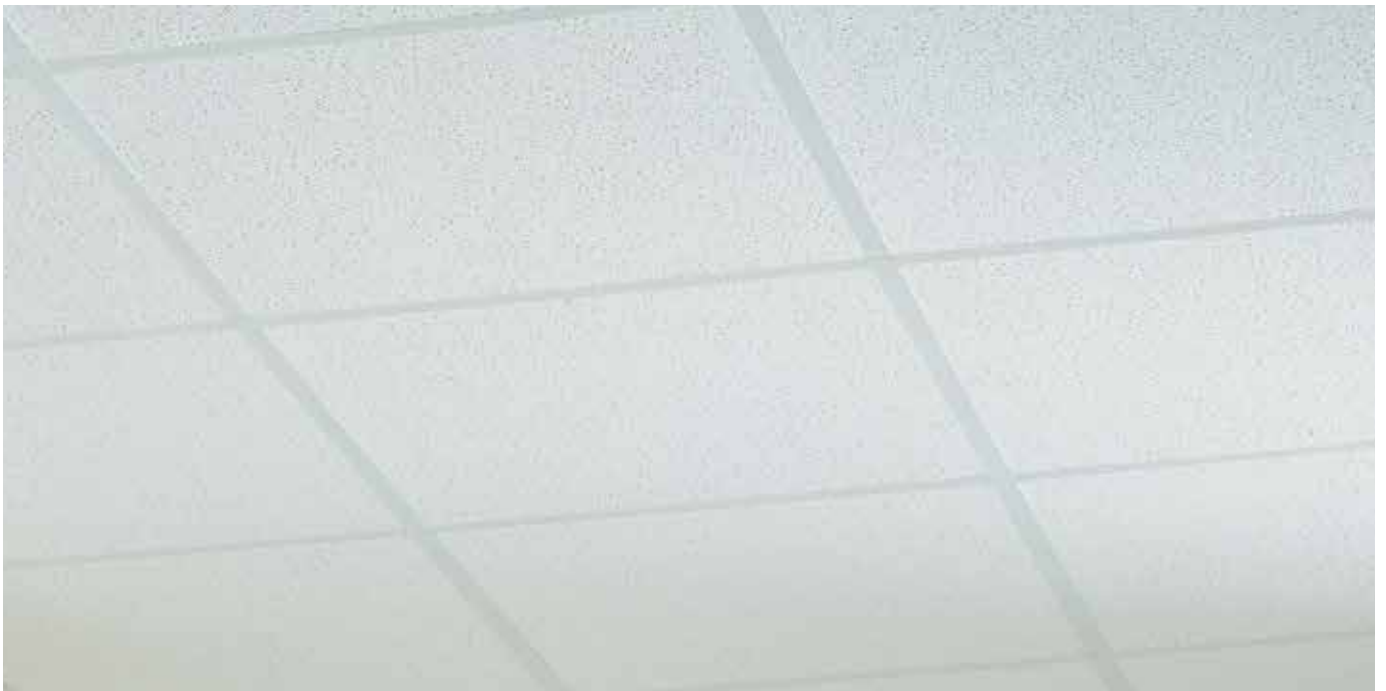
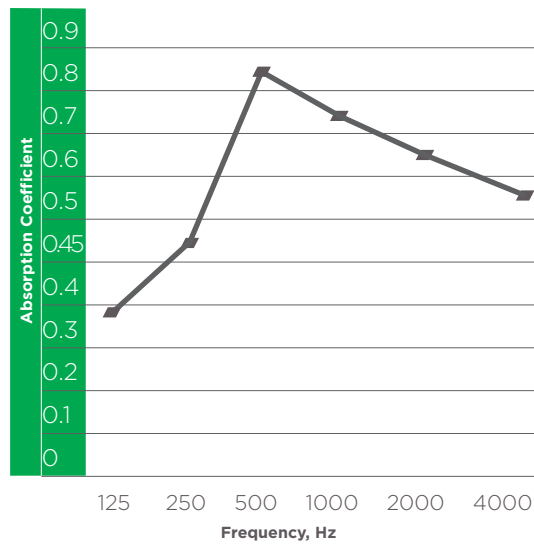

Item	Size	Edge Detail	NRC	CAC	LR	Recycled Content	VOC Emission	Cost
ATS665 ATS225	600*600*15 610*610*15	SQ	0.5	35	86%	32%	Low	\$
ATSR665 ATSR225	600*600*15 610*610*15	SLT	0.5	35	86%	32%	Low	\$
ATSRF665 ATSRF225	600*600*15 610*610*15	FLB	0.5	35	86%	32%	Low	\$
ATC665 ATC225	600*600*15 610*610*15	SQ	0.5	35	86%	32%	Low	\$
ATCR665 ATCR225	600*600*15 610*610*15	SLT	0.5	35	86%	32%	Low	\$
ATCRF665 ATCRF225	600*600*15 610*610*15	FLB	0.5	35	86%	32%	Low	\$
ATC669 ATC229	600*600*19 610*610*19	SQ	0.65	37	86%	32%	Low	\$\$
ATCR669 ATCR229	600*600*19 610*610*19	SLT	0.65	37	86%	32%	Low	\$\$
ATCRF669 ATCRF229	600*600*19 610*610*19	FLB	0.65	37	86%	32%	Low	\$\$

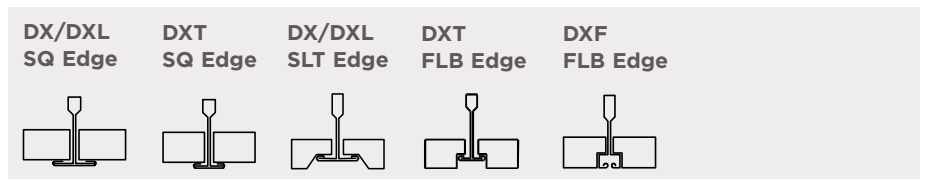

PART 2- PRODUCT

Product Specification Details | Acoustical Ceilings | 09 51 13

2.1 General

Provide Acoustical Ceiling Material manufactured to meet requirements of this specification in accordance with ASTM E 1264 and EN 13964.

2.2 Materials

Acoustical Ceiling Units:

1. Type III, Form 2, Pattern [C] [E]
2. Accessible acoustical ceiling system with pin perforated panels
3. Size 15, 19mm thick [600 x 600]
4. Edge Detail Trim (Square), Reveal (SLT) (FLB)
5. Noise Reduction Coefficient (NRC) [0.5] [0.65]
6. Ceiling Attenuation Class (CAC) [35-37 dB]
7. Light Reflectance Coefficient (LR) 0.86
8. Recycled Content [32%]
9. Color White similar to RAL 9016
10. Surface Burning Characteristics per ASTM E 84 Class A, Flame Spread: 10, Smoke development: 20 Reaction to Fire: Euroclass A2-s1,d0 in accordance with EN-13501-1
11. Thermal Resistance: 0.23 m² °K/W - R 1.3 (15mm), 0.31 m² °K/W - R 1.8 (19mm)
12. Humidity Resistance Maximum 99% RH / 40°C for ClimaPlus
13. Weight: 3.55 kg/m² (Regular / ClimaPlus) 15mm, 4.5 kg/m² (Regular / ClimaPlus) 19mm
14. Mold Prevention application available upon request per ASTM D3273-1, Rate 10 per D3274
15. Relevant LEED Credit: EA Credit 1 | MR Credit 4| MR Credit 5 | MR Credit 6 IEQ Credit 3 | IEQ Credit 3.2 | IEQ Credit 4.6 | IEQ Credit 8.1 | IEQ Credit 9
16. Manufacturer, subject to compliance with USG Boral ME terms & Conditions
17. Product Name [Athena]

CHESSBOARD

STANDARD SPECIFICATION

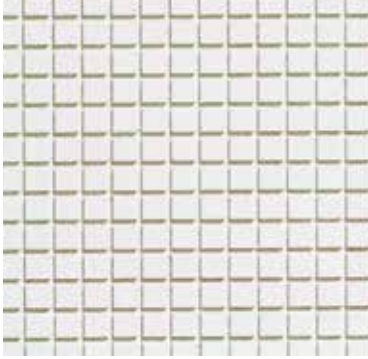

Features & Benefits:

- Fine non directional Face Cut panels with 529 squares
- Shallow geometric square or linear face cuts disguise the grid for a monolithic appearance
- Scored with one face style and smooth surface without any Perforation
- Low sound absorption, ideal where increase room reverberation is desired
- Mid-range sound attenuation, ideal for general commercial construction
- Easy to trim and install

Applications:

- Schools
- Corridors
- Waiting Rooms
- Leisure
- General Offices
- Retail Stores



Item	Size	Edge Detail	NRC	CAC	LR	Recycled Content	VOC Emission	Cost
CHSR669	600*600*19	SLT	0.3	35	83%	32%	Low	\$\$
CHSR229	610*610*19							

**DX /DXL
SLT Edge**

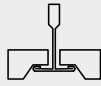

PART 2- PRODUCT

Product Specification Details | Acoustical Ceilings | 09 51 13

2.1 General

Provide Acoustical Ceiling Material manufactured to meet requirements of this specification in accordance with ASTM E 1264 and EN 13964.

2.2 Materials

Acoustical Ceiling Units:

1. Type III, Form 2, Pattern [E] [K]
2. Fine non-directional face cut panel
3. Size 19 mm thick [600 x 600]
4. Edge Detail Reveal (SLT)
5. Noise Reduction Coefficient (NRC) [0.3]
6. Ceiling Attenuation Class (CAC) [35 dB]
7. Light Reflectance Coefficient (LR) 0.83
8. Recycled Content [32%]
9. Color White similar to RAL 9016
10. Surface Burning Characteristics per ASTM E 84 Class A, Flame Spread: 10, Smoke development: 20 Reaction to Fire: Euroclass A2-s1,d0 in accordance with EN-13501-1
11. Thermal Resistance: 0.31 m² °K/W - R 1.8 (19mm)
12. Humidity Resistance Maximum 90% RH / 30°C for ClimaPlus
13. Weight: 4.5kg/m²
14. Mold Prevention application available upon request per ASTM D3273-1, Rate 10 per D3274
15. Relevant LEED Credit: EA Credit 1 | MR Credit 4 | MR Credit 5 | MR Credit 6 | IEQ Credit 3 | IEQ Credit 3.2 | IEQ Credit 4.6 | IEQ Credit 8.1 | IEQ Credit 9
16. Manufacturer, subject to compliance with USG Boral ME terms & Conditions
17. Product Name [Chessboard]

CLEAN ROOM™

STANDARD SPECIFICATION

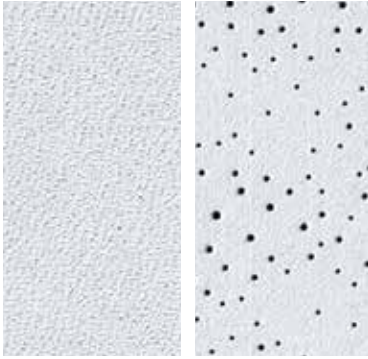

Features & Benefits:





- Have an embossed, vinyl-laminated face with sealed back and edges for use in Class 100 (cross reference to Class 5 per ISO 14644-1) or 10M-100M clean rooms as per Federal standard 209E for Classification by Airborne particles
- Made with Fire code base materials to meet life safety codes
- Available in un-perforated finish for Kitchen & food preparation areas and perforated to meet acoustical requirements in hospitals
- Classified HRC panels (High Recycled Content) which is greater than 50%
- Required to be used with CE grid (gasketed tee flanges) for Operating theaters & MRI rooms
- Certified USDA/FSIS bio based product requirements for food processing areas where Clean Room™ has achieved both Bio-Preferred initiatives: Federal Procurement Preference and Certified Product Labeling
- Cleanroom classified, meets Federal Spec. 209E for non-perforated “Clean Room™ and work station Requirements, controlled environment”
- Washable, scrubbable resistance
- High humidity resistant and anti-mold, mildew growth

Applications:

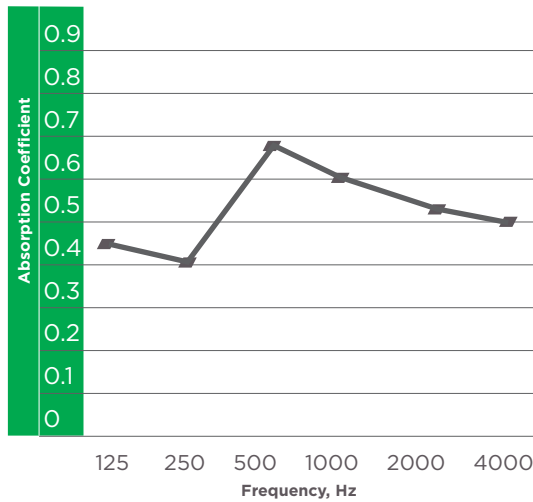
- Sterile rooms
- Laboratories
- Food/ beverage processing (non-perforated only)
- Emergency rooms
- Toilet/Wet rooms
- Operating/MRI rooms

CLEAN ROOM™ SOUND ABSORPTION - 19 MM



Item	Size	Edge Detail	NRC	CAC	LR	Recycled Content	VOC Emission	Cost
 CLX625 CLX245	600x1200x15	SQ	0.15	37	80%	52%	N/A	\$\$\$\$
	610x1220x15							
 CLX665 CLX225	600*600*15	SQ	0.15	37	80%	52%	N/A	\$\$\$\$
	610*610*15							
 CLXP665 CLXP225	600*600*15	SQ	0.55	35	79%	52%	N/A	\$\$\$\$
	610*610*15							
 CLXP625 CLXP245	600*1200*15	SQ	0.55	35	79%	52%	N/A	\$\$\$\$
	610*1220*15							

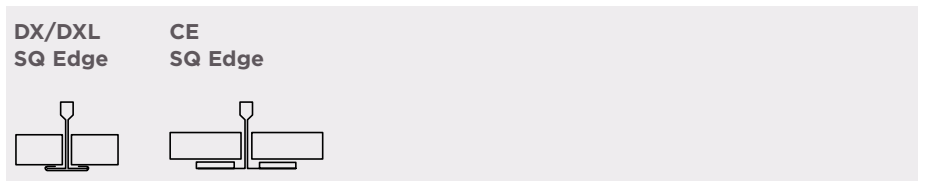

PART 2- PRODUCT

Product Specification Details | Acoustical Ceilings | 09 51 13

2.1 General

Provide Acoustical Ceiling Material manufactured to meet requirements of this specification in accordance with ASTM E 1264 and EN 13964.

2.2 Materials

Acoustical Ceiling Units:

1. Type X, Pattern [C] [G] [I]
2. Embossed Vinyl-faced with field cut-edges sealed with white latex paint
3. Size 15mm thick [600 x 600] [600 x 1200]
4. Edge Detail Trim (Square)
5. Noise Reduction Coefficient (NRC) [0.15] [0.55]
6. Ceiling Attenuation Class (CAC) [35-37 dB]
7. Light Reflectance Coefficient (LR) 0.8
8. Recycled Content [52%]
9. Color White similar to RAL 9016
10. Surface Burning Characteristics per ASTM E 84 Class A, Flame Spread: 10, Smoke development: 20 Reaction to Fire: Euroclass A2-s1,d0 in accordance with EN-13501-1
11. Underwriters Laboratories Inc. Fire-Resistance (ASTM E 119) ANSI/UL 263 Time-Rated Assembly [3hrs] [D218]
12. Thermal Resistance: 0.23 m² °K/W - R 1.3 (15mm)
13. Humidity Resistance Maximum 99% RH / 40°C
14. Weight: 5.25 kg/m²
15. Mold Prevention: Inherent to Mold/Mildew growth
16. Relevant LEED Credit: EA Credit 1 | MR Credit 4 | MR Credit 5 | MR Credit 6 IEQ Credit 3 | IEQ Credit 3.2 | IEQ Credit 4.6 | IEQ Credit 8.1 | IEQ Credit 9
17. Manufacturer, subject to compliance with USG Boral ME terms & Conditions
18. Product Name [Clean Room™]

COMET LINE

STANDARD SPECIFICATION



Features & Benefits:

- Fine directional Face Cut panels
- Shallow linear face cuts that enable the creation of subtle shadow effect
- Scored with one face style 23 lines and smooth surface without any Perforation
- Low sound absorption, ideal where increased room reverberation is desired
- Easy to trim and install

Applications:

- Schools
- Corridors
- Waiting Rooms
- Theaters



Item	Size	Edge Detail	NRC	CAC	LR	Recycled Content	VOC Emission	Cost
CSR669	600*600*19	SLT	0.3	35	83%	32%	Low	\$\$
CSR229	610*610*19							

DX /DXL
SLT Edge

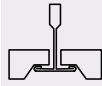

PART 2- PRODUCT

Product Specification Details | Acoustical Ceilings | 09 51 13

2.1 General

Provide Acoustical Ceiling Material manufactured to meet requirements of this specification in accordance with ASTM E 1264 and EN 13964.

2.2 Materials

Acoustical Ceiling Units:

1. Type III, Form 2, Pattern [E] [K]
2. Accessible acoustical ceiling system with fine directional face cut panels
3. Size 19mm thick [600 x 600]
4. Edge Detail Reveal (SLT)
5. Noise Reduction Coefficient (NRC) [0.3]
6. Ceiling Attenuation Class (CAC) [35 dB]
7. Light Reflectance Coefficient (LR) 0.83
8. Recycled Content [32%]
9. Color White similar to RAL 9016
10. Surface Burning Characteristics per ASTM E 84 Class A, Flame Spread: 10, Smoke development: 20 Reaction to Fire: Euroclass A2-s1,d0 in accordance with EN-13501-1
11. Thermal Resistance: 0.31 m² °K/W - R 1.8 (19mm)
12. Humidity Resistance Maximum 90% RH / 30°C for ClimaPlus
13. Weight: 4.5 kg/m²
14. Mold Prevention application available upon request per ASTM D3273-1, Rate 10 per D3274
15. Relevant LEED Credit: EA Credit 1 | MR Credit 4| MR Credit 5 | MR Credit 6 IEQ Credit 3 | IEQ Credit 3.2 | IEQ Credit 4.6 | IEQ Credit 8.1 | IEQ Credit 9
16. Manufacturer, subject to compliance with USG Boral ME terms & Conditions
17. Product Name [Comet Line]

CROSS FISSURED

STANDARD SPECIFICATION



Features & Benefits:

- Economical, all-purpose ceiling pattern available in various panel sizes
- Directionally fissured panels excellent choice for large ceiling areas
- Mid-range sound absorption and sound attenuation which make it ideal for Schools, Corridors and general commercial stores
- Available in 19mm Thickness for NRC value 0.6
- Optional FIRECODE™ formulation designed to meet life safety codes
- Meets the emission test criteria as low emitting per standards established by the Collaborative for High-Performance Schools (CHPS) and following ASTM D5116 testing method

Applications:

- Education
- Corridors/Hallways
- Mass Merchandisers
- Convenience Stores
- Offices
- Warehouse

CROSS FISSURED SOUND ABSORPTION - 19MM

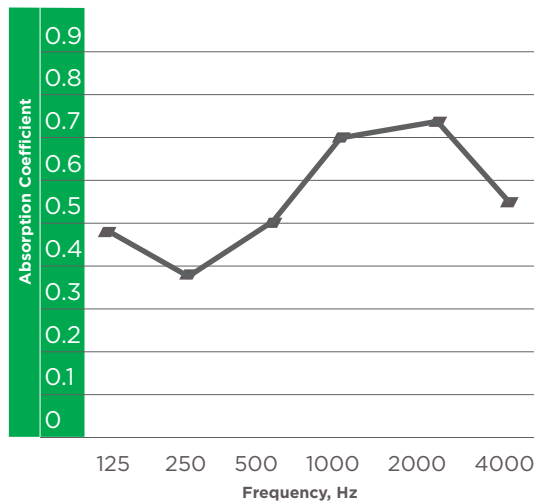

Item	Size	Edge Detail	NRC	CAC	LR	Recycled Content	VOC Emission	Cost
CFS665	600*600*15	SQ	0.5	35	82%	32%	Low	\$
CFS225	610*610*15							
CFSR665	600*600*15	SLT	0.5	35	82%	32%	Low	\$
CFSR225	610*610*15							
CFC625	600*1200*15	SQ	0.5	35	82%	32%	Low	\$
CFC245	610*1220*15							
CFX665	600*600*15	SQ	0.5	35	82%	46%	Low	\$\$
CFX225	610*610*15							
CFS669	600*600*19	SQ	0.6	37	82%	32%	Low	\$\$
CFS229	610*610*19							
CFX669	600*600*19	SQ	0.6	37	82%	32%	Low	\$\$\$
CFX229	610*610*19							

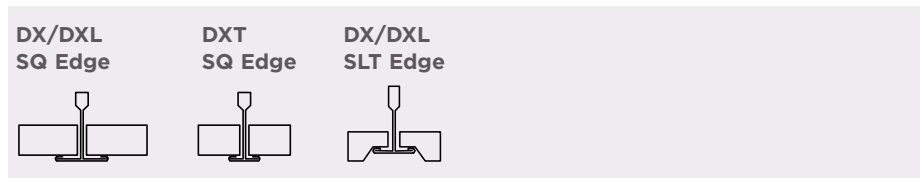

PART 2- PRODUCT

Product Specification Details | Acoustical Ceilings | 09 51 13

2.1 General

Provide Acoustical Ceiling Material manufactured to meet requirements of this specification in accordance with ASTM E 1264 and EN 13964.

2.2 Materials

Acoustical Ceiling Units:

1. Type III, Form 2, Pattern [C] [D]
2. Directional fissured wet-felted
3. Size 15,19 mm thick [600 x 600] [600 x 1,200]
4. Edge Detail Trim (Square), Reveal (SLT)
5. Noise Reduction Coefficient (NRC) [0.5] [0.6]
6. Ceiling Attenuation Class (CAC) [35-37 dB]
7. Light Reflectance Coefficient (LR) 0.82
8. Recycled Content [32%] [46%]
9. Color White similar to RAL 9016
10. Surface Burning Characteristics per ASTM E 84 Class A, Flame Spread: 10, Smoke development: 20 Reaction to Fire: Euroclass A2-s1,d0 in accordance with EN-13501-1
11. Underwriters Laboratories Inc. Fire-Resistance (ASTM E 119) ANSI/UL 263 Time-Rated Assembly [2hrs] [J201]
12. Thermal Resistance: 0.23 m² °K/W - R 1.3 (15mm), 0.31 m² °K/W - R 1.8 (19mm)
13. Humidity Resistance Maximum 90% RH / 30°C
14. Weight: 3.55 kg/m² (Regular / ClimaPlus) 15mm, 5 kg/m² (Fire code) 15mm, 4.5 kg/m² (Regular / ClimaPlus) 19mm, 6.85 kg/m² (Fire code) 19mm
15. Mold Prevention application available upon request per ASTM D3273-1, Rate 10 per D3274
16. Relevant LEED Credit: EA Credit 1 | MR Credit 4 | MR Credit 5 | MR Credit 6 | IEQ Credit 3 | IEQ Credit 3.2 | IEQ Credit 4.6 | IEQ Credit 8.1 | IEQ Credit 9
17. Manufacturer, subject to compliance with USG Boral ME terms & Conditions
18. Product Name [Cross Fissured]

DESIGNER SERIES

STANDARD SPECIFICATION



Features & Benefits:

- 360 ° non directional pattern with a fresh, clean appearance offers fast, economical installation
- Shallow geometric square face cuts disguise the grid for a monolithic appearance, thus making it appear part of the overall ceiling design
- Face Scores create illusion of a smaller-scaled ceiling system
- Available into 4 different face style ranging from smooth to textured surfaces
- Low to Mid-range sound attenuation, ideal for general commercial construction
- Fire resistant system options, for life safety & protection of property
- Easy to trim and install

Applications:

- Reception
- Shopping Centers
- Waiting Rooms
- Café/Restaurants
- General Offices
- Luxury Retail stores



Item	Size	Edge Detail	NRC	CAC	LR	Recycled Content	VOC Emission	Cost
QCFSR669	600*600*19	SLT	0.15	35	83%	32%	Low	\$\$\$
QCFSR229	610*610*19							
QPSR669	600*600*19	SLT	0.15	35	83%	32%	Low	\$\$\$
QPSR229	610*610*19							
QBCR669	600*600*19	SLT	0.15	37	83%	32%	Low	\$\$\$
QBCR229	610*610*19							
QBCR669 (36/15)	600*600*19	SLT	0.15	35	83%	32%	Low	\$\$\$\$
QBCR229 (36/15)	610*610*19							
QOLPCR669 (36/15)	600*600*19	SLT	0.65	37	88%	39%	Low	\$\$\$\$
QOLPCR229 (36/15)	610*610*19							
QRDCR669 (36/15)	600*600*19	SLT	0.6	35	84%	32%	Low	\$\$\$\$
QRDCR229 (36/15)	610*610*19							
QRDCR669 (81/5)	600*600*19	SLT	0.6	35	84%	32%	Low	\$\$\$\$
QRDCR229 (81/5)	610*610*19							

**DX/DXL
SLT Edge**

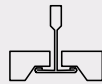

PART 2- PRODUCT

Product Specification Details | Acoustical Ceilings | 09 51 13

2.1 General

Provide Acoustical Ceiling Material manufactured to meet requirements of this specification in accordance with ASTM E 1264 and EN 13964.

2.2 Materials

Acoustical Ceiling Units:

1. Type III, Form 2, Pattern [C] [D] [E] [G] [K]
2. Fine non-directional fissured panel
3. Size 19mm thick [600 x 600]
4. Edge Detail Trim (Square), Reveal (SLT)
5. Noise Reduction Coefficient (NRC) [0.15] [0.65]
6. Ceiling Attenuation Class (CAC) [35-37 dB]
7. Light Reflectance Coefficient (LR) 0.83, 0.88
8. Recycled Content [32-39%]
9. Color White similar to RAL 9016
10. Surface Burning Characteristics per ASTM E 84 Class A, Flame Spread: 10, Smoke development: 20 Reaction to Fire: Euroclass A2-s1,d0 in accordance with EN-13501-1
11. Thermal Resistance: 0.31 m² °K/W - R 1.8 (19mm)
12. Humidity Resistance Maximum 90% RH / 30°C for ClimaPlus
13. Weight: 4.5 - 5 kg/m²
14. Mold Prevention application available upon request per ASTM D3273-1, Rate 10 per D3274
15. Relevant LEED Credit: EA Credit 1 | MR Credit 4 | MR Credit 5 | MR Credit 6 | IEQ Credit 3 | IEQ Credit 3.2 | IEQ Credit 4.6 | IEQ Credit 8.1 | IEQ Credit 9
16. Manufacturer, subject to compliance with USG Boral ME terms & Conditions
17. Product Name [Designer Series]

FAVIA

STANDARD SPECIFICATION

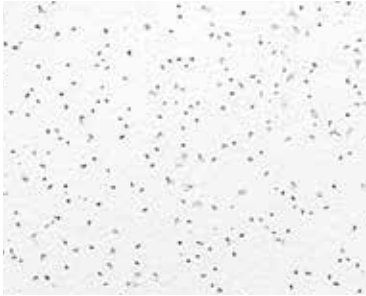

Features & Benefits:

- Finest Fissuring pattern among USG Boral ME product portfolio
- Elegant non directional pattern for a fresh, clean and white appearance
- Economical series ideal for Retail Business and general commercial stores
- High light reflectance ceilings that can reduce the light fixtures needed and maintaining good indoor environmental air-quality
- Meets the emission test criteria as low emitting per standards established by the Collaborative for High-Performance Schools (CHPS) and following ASTM D5116 testing method

Applications:

- Groceries
- Corridors/Hallways
- Basements
- Administration Offices
- Rest Areas
- Cafeterias
- Warehouse



Item	Size	Edge Detail	NRC	CAC	LR	Recycled Content	VOC Emission	Cost
FNS665	600*600*15	SQ	0.25	35	85%	32%	Low	\$
FNS225	610*610*15							
FNSR665	600*600*15	SLT	0.25	35	85%	32%	Low	\$
FNSR225	610*610*15							

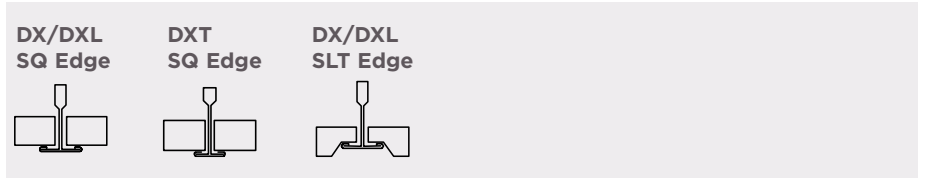

PART 2- PRODUCT

Product Specification Details | Acoustical Ceilings | 09 51 13

2.1 General

Provide Acoustical Ceiling Material manufactured to meet requirements of this specification in accordance with ASTM E 1264 and EN 13964.

2.2 Materials

Acoustical Ceiling Units:

1. Type III, Form 2, Pattern [D] [E]
2. Fine non-directional Fine fissured panel
3. Size 15 mm thick [600 x 600]
4. Edge Detail Trim (Square), Reveal (SLT)
5. Noise Reduction Coefficient (NRC) [0.25]
6. Ceiling Attenuation Class (CAC) [35 dB]
7. Light Reflectance Coefficient (LR) 0.85
8. Recycled Content [32%]
9. Color White similar to RAL 9016
10. Surface Burning Characteristics per ASTM E 84 Class A, Flame Spread: 10, Smoke development: 20 Reaction to Fire: Euroclass A2-s1,d0 in accordance with EN-13501-1
11. Thermal Resistance: 0.23 m² °K/W - R 1.3 (15mm)
12. Weight: 3.55 kg/m² (Regular) 15mm
13. Humidity Resistance Maximum 95% RH / 40°C ClimaPlus
14. Mold Prevention application available upon request per ASTM D3273-1, Rate 10 per D3274
15. Relevant LEED Credit: EA Credit 1 | MR Credit 4| MR Credit 5 | MR Credit 6 IEQ Credit 3 | IEQ Credit 3.2 | IEQ Credit 4.6 | IEQ Credit 8.1 | IEQ Credit 9
16. Manufacturer, subject to compliance with USG Boral ME terms & Conditions
17. Product Name [Favia]

FAVIA ACOUSTIC

STANDARD SPECIFICATION

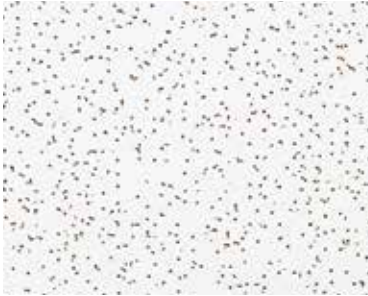

Features & Benefits:

- Micro-Fissured non directional pattern for a cleaner, whiter appearance
- Elegant light-textured panels with high Light reflectance
- Mid-range sound absorption and sound attenuation which make it ideal for Schools, Corridors and general commercial stores
- Available in 19mm Thickness for NRC value 0.6
- Meets the emission test criteria as low emitting per standards established by the Collaborative for High-Performance Schools (CHPS) and following ASTM D5116 testing method

Applications:

- Education
- Corridors/Hallways
- Grocery Stores
- Administration Offices
- Restaurants
- Warehouse

FAVIA ACOUSTIC SOUND ABSORPTION - 19 MM

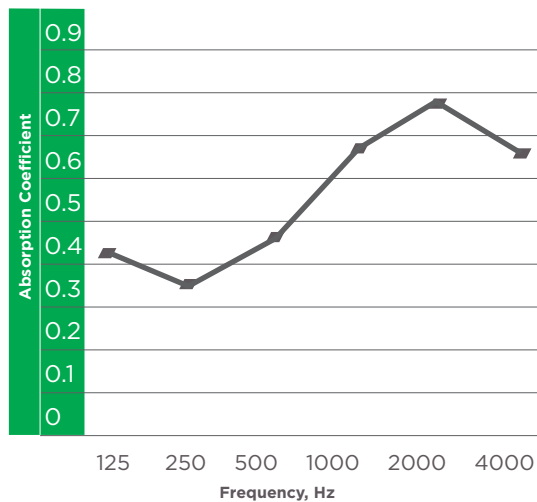

Item	Size	Edge Detail	NRC	CAC	LR	Recycled Content	VOC Emission	Cost
FAS665	600*600*15	SQ	0.5	35	85%	32%	Low	\$
FAS225	610*610*15							
FASR665	600*600*15	SLT	0.5	35	85%	32%	Low	\$
FASR225	610*610*15							
FAS669	600*600*19	SQ	0.6	37	85%	32%	Low	\$\$
FAS229	610*610*19							
FASR669	600*600*19	SLT	0.6	37	85%	32%	Low	\$\$
FASR229	610*610*19							

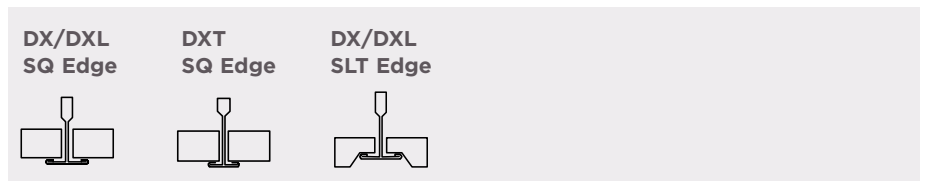

PART 2- PRODUCT

Product Specification Details | Acoustical Ceilings | 09 51 13

2.1 General

Provide Acoustical Ceiling Material manufactured to meet requirements of this specification in accordance with ASTM E 1264 and EN 13964.

2.2 Materials

Acoustical Ceiling Units:

1. Type III, Form 2, Pattern [C] [D] [E]
2. Fine non-directional fissured panel
3. Size 15,19 mm thick [600 x 600]
4. Edge Detail Trim (Square), Reveal (SLT)
5. Noise Reduction Coefficient (NRC) [0.5] [0.6]
6. Ceiling Attenuation Class (CAC) [35-37 dB]
7. Light Reflectance Coefficient (LR) 0.85
8. Recycled Content [32%]
9. Color White similar to RAL 9016
10. Surface Burning Characteristics per ASTM E 84 Class A, Flame Spread: 10, Smoke development: 20 Reaction to Fire: Euroclass A2-s1,d0 in accordance with EN-13501-1
11. Thermal Resistance: 0.23 m² °K/W - R 1.3 (15mm), 0.31 m² °K/W - R 1.8 (19mm)
12. Weight: 3.55 kg/m² (Regular) 15mm, 4.5 kg/m² (Regular) 19mm
13. Humidity Resistance Maximum 95% RH / 40°C ClimaPlus
14. Mold Prevention application available upon request per ASTM D3273-1, Rate 10 per D3274
15. Relevant LEED Credit: EA Credit 1 | MR Credit 4 | MR Credit 5 | MR Credit 6 | IEQ Credit 3 | IEQ Credit 3.2 | IEQ Credit 4.6 | IEQ Credit 8.1 | IEQ Credit 9
16. Manufacturer, subject to compliance with USG Boral ME terms & Conditions
17. Product Name [Favia Acoustic]

FROST™

STANDARD SPECIFICATION



Features & Benefits:

- Manufactured in CAST process that creates natural, subtle texture variation which is a distinguishing feature of these products
- Delicate surface texture for a soft, light look
- Fine Textured and nearly 2 times more impact-resistant than typical fine-textured ceiling panels (ASTM C367)
- Exclusive Clear and Integral color masks nicks and scratches
- Excellent for critical lighting applications for Frost™ High Light Reflectance (0.89)
- Excellent Combination of High NRC 0.8 (absorption) and High CAC up to 40 (privacy) for use in mixed (open plan/closed plan) office design
- HRC (High Recycled Content) for optimized recycled content formulations to help maximize LEED recycled content contribution
- Available in Reveal Beveled Edge panels, high humidity resistance up to 95%RH and in Fire Code Formulation for life safety and protection of property
- Zero VOC emissions exceeds the most stringent air quality standards
- Paper backing acts as a sound barrier and resists air filtration for cleaner panels

Applications:

- Healthcare - HIPAA Requirements
- Schools - ANSI S12.60 Classroom guidelines
- Government Projects - ACOE performance requirements
- Open or Closed Plan offices
- Mixed Office Design
- Media Centers/Libraries

FROST SOUND ABSORPTION

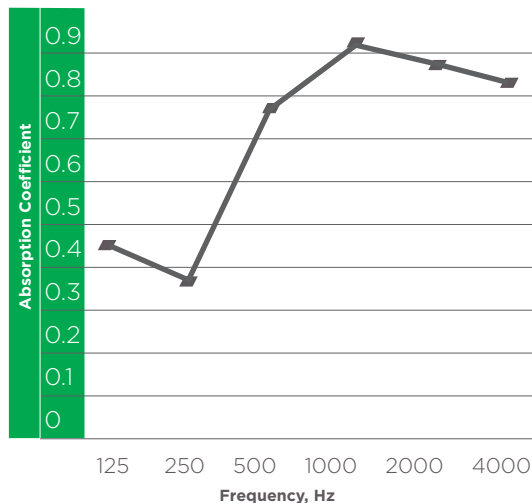

Item	Size	Edge Detail	NRC	CAC	LR	Recycled Content	VOC Emission	Cost
484 Paper Back	610*610*22	SLB	0.8	38	89%	73%	Zero	\$\$\$
418 Paper Back	610*610*19	FL	0.7	40	84%	72%	Zero	\$\$\$

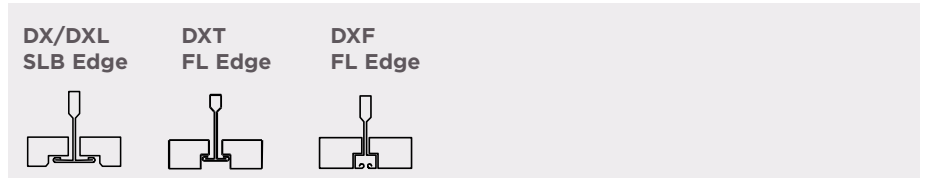

PART 2- PRODUCT

Product Specification Details | Acoustical Ceilings | 09 51 13

2.1 General

Provide Acoustical Ceiling Material manufactured to meet requirements of this specification in accordance with ASTM E 1264.

2.2 Materials

Acoustical Ceiling Units:

1. Type III, Form 4, Pattern [E]
2. Fine textured panels
3. Size 19,22 mm thick [610 x 610]
4. Edge Detail Reveal (SLB) (FL)
5. Noise Reduction Coefficient (NRC) [0.7-0.8]
6. Ceiling Attenuation Class (CAC) [38-40 dB]
7. Light Reflectance Coefficient (LR) up to 0.89
8. Recycled Content up to [73%]
9. Color White similar to RAL 9016
10. Surface Burning Characteristics per ASTM E 84 Class A, Flame Spread:25, Smoke development:50
11. Thermal Resistance: R 1.7 (Class A), R 1.1 (Fire Code)
12. Humidity Resistance Maximum 95% RH / 40°C ClimaPlus
13. Weight: 8 kg/m² (Class A), 8.65 kg/m² (Fire code)
14. Mold Prevention application per ASTM D3273-1, Rate 10 per D3274
15. VOC Class: Zero emission per CHPS Collaborative for High-Performance Schools
16. Relevant LEED Credit: EA Credit 1 | MR Credit 4 | MR Credit 5 | MR Credit 6 | IEQ Credit 3 | IEQ Credit 3.2 | IEQ Credit 4.6 | IEQ Credit 8.1 | IEQ Credit 9
17. Manufacturer, subject to compliance with USG Boral ME terms & Conditions
18. Product Name [Frost™]

GLACIER™

STANDARD SPECIFICATION

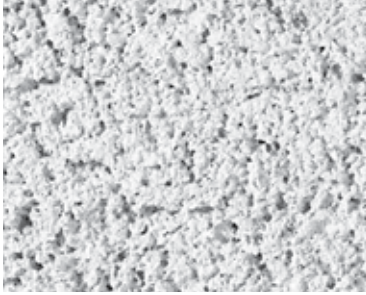

Features & Benefits:



- Manufactured in CAST process for a durable surface that resist scrapes commonly caused by accessing ceiling plenum
- Heavily textured panels with rich surface details variation which is a distinguishing feature of these products
- Integral color masks nicks and scratches and enhances lifelong panel appearance
- HRC (High Recycled Content) for optimized recycled content formulations to help maximize LEED recycled content contribution
- Available in 300 x 300mm panel with DONN® Brand DX/DXL concealed suspension system to create a monolithic ceiling surface
- Available also in Fire Code Formulation for life safety and protection of property
- Zero VOC emissions exceeds the most stringent air quality standards
- All panels are backed with Aluminum foil which acts as a sound barrier and resists air filtration for cleaner panels

Applications:

- Libraries
- Restaurant
- Hospitality
- Airport

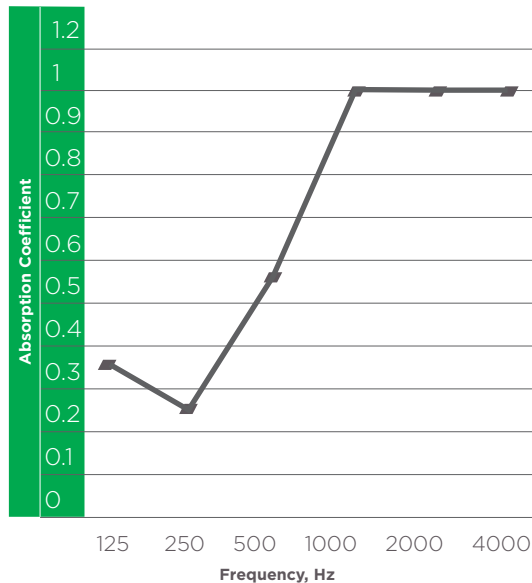
GLACIER™ SOUND ABSORPTION



Item	Size	Edge Detail	NRC	CAC	LR	Recycled Content	VOC Emission	Cost
 708 Paper-Back	610*610*19	FL	0.65	35	70%	72%	Zero	\$\$\$
 715 Paper-Back	610*610*19	SL	0.65	35	70%	73%	Zero	\$\$\$



PART 2- PRODUCT

Product Specification Details | Acoustical Ceilings | 09 51 13

2.1 General

Provide Acoustical Ceiling Material manufactured to meet requirements of this specification in accordance with ASTM E 1264.

2.2 Materials

Acoustical Ceiling Units:

1. Type III, Form 4, Pattern [F]
2. Heavy textured panels
3. Size 19 mm thick [300 x 300] , [610 x 610]
4. Edge Detail Reveal (SL) (FL) (SESK)
5. Noise Reduction Coefficient (NRC) [0.65]
6. Ceiling Attenuation Class (CAC) [35 dB]
7. Light Reflectance Coefficient (LR) up to 0.7
8. Recycled Content [71%]
9. Available in various Color
10. Surface Burning Characteristics per ASTM E 84 Class A, Flame Spread:25, Smoke development:50
11. Underwriters Laboratories Inc. Fire-Resistance (ASTM E 119) ANSI/UL 263 Time-Rated Assembly [2hrs] [G228]
12. Thermal Resistance: R 1.7 (Class A), R 1.3 (Fire Code)
13. Weight: 7 kg/m² (Class A), 7.5 kg/m² (Fire code)
14. VOC Class: Zero emission per CHPS Collaborative for High-Performance Schools
15. Relevant LEED Credit: EA Credit 1 | MR Credit 4| MR Credit 5 | MR Credit 6 | IEQ Credit 3 IEQ Credit 3.2 | IEQ Credit 4.6 | IEQ Credit 8.1 | IEQ Credit 9
16. Manufacturer, subject to compliance with USG Boral ME terms & Conditions
17. Product Name [Glacier™]

HALCYON™

STANDARD SPECIFICATION



Features & Benefits:

- Fiber Glass substrate with monolithic visual reducing installation time
- Exceptional Sound Absorption with NRC values up to 1
- High Light Reflectance (LR-0.88) reduces light fixtures & Energy use
- Washable & Scrubbable finish
- Impact & Scratch Resistant
- Available in Plank Sizes compatible with Logix Integrated Ceiling System
- Available in black for ideal application in cinemas and operating theaters

Applications:

- Open-plan Areas
- Offices with indirect lighting
- Media Rooms
- Receptions & Lobby Areas
- Libraries
- Convention halls and concourses
- Cinemas and operating theaters

HALCYON™ SOUND ABSORPTION - 19 MM

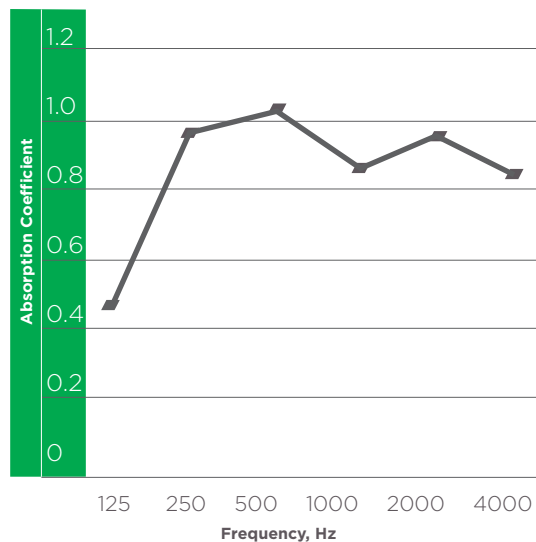

	Item	Size	Edge Detail	NRC	CAC	LR	Recycled Content	VOC Emission	Cost
☀️	HC669	600*600*19	SQ	0.95	24	88%	40%	N/A	\$\$\$\$
	HC229	610*610*19							
☀️	HC629	600*1200*19	SQ	0.95	24	88%	40%	N/A	\$\$\$\$
	HC249	610*1220*19							
☀️	HC6625	600*600*25	SQ	1	25	88%	40%	N/A	\$\$\$\$
	HC2225	610*610*25							
☀️	HC6225B	600*1200*25	SQ	0.9	25	-	40%	N/A	\$\$\$\$
	HC2425B	610*1220*25							
☀️	HC6638	600*600*38	SQ	1	31	88%	40%	N/A	\$\$\$\$
	HC2238	610*610*38							
☀️	HCR6625	600*600*25	SL	0.95	28	88%	40%	N/A	\$\$\$\$
	HCR2225	610*610*25							
☀️	HCR6225	600*1200*25	SL	0.95	28	88%	40%	N/A	\$\$\$\$
	HCR2425	610*1220*25							
☀️	HCR6638	600*600*38	SL	1	31	88%	43%	N/A	\$\$\$\$
	HCR2238	610*610*38							
☀️	HCRF6625	600*600*25	FL	0.95	28	88%	40%	N/A	\$\$\$\$
	HCRF2225	610*610*25							
☀️	HCRF6225B	600*1200*25	FL	0.95	28	88%	40%	N/A	\$\$\$\$
	HCRF2425B	610*1220*25							
☀️	HCRF6638	600*600*38	FL	1	31	88%	43%	N/A	\$\$\$\$
	HCRF2238	610*610*38							

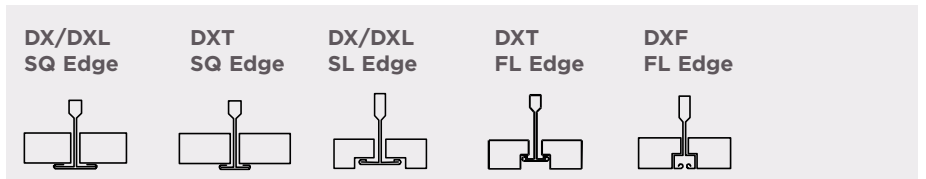

PART 2- PRODUCT

Product Specification Details | Acoustical Ceilings | 09 51 13

2.1 General

Provide Acoustical Ceiling Material manufactured to meet requirements of this specification in accordance with ASTM E 1264.

2.2 Materials

Acoustical Ceiling Units:

1. Type XII, Form 2, Pattern [E,G]
2. Fiber Glass Substrate finished with Painted Fiber Glass scrim
3. Size 19, 25, 38 mm thick [600 x 600] [600 x 1200] [300 x 1200] [300 x 1500] [600 x 1500] [300*1800] [600*1800]
4. Edge Detail Trim (Square), Reveal (SL)(FL)
5. Noise Reduction Coefficient (NRC) [0.95][1]
6. Ceiling Attenuation Class (CAC) [24-31 dB]
7. Light Reflectance Coefficient (LR) 0.88 for white
8. Recycled Content [40%]
9. Color White similar to RAL 9016 and Black similar to RAL 9005
10. Surface Burning Characteristics per ASTM E84 Class A, Flame Spread:25, Smoke development: 50
11. Thermal Resistance: 0.6 m² °K/W - R 3.5 (19mm), 0.74 m² °K/W - R 4.2 (25mm)
12. Humidity Resistance Maximum 99% RH / 40°C, ClimaPlus
13. Weight: 1.7 kg/m² for 15mm, 2.1 kg/m² for 19mm, 2.4 kg/m² for 25mm and 3.4 Kg/m² for 38mm
14. Mold Prevention: Fiberglass substrate is inherently resistant to the growth of mold and mildew
15. Washability / Scrubbability: Exceeds 1000 Wash/Scrub Cycles without surface break or the extent of abrasion per ASTM D4828 & D2486
16. Relevant LEED Credit: EA Credit 1 | MR Credit 4| MR Credit 5 | MR Credit 6 IEQ Credit 3 | IEQ Credit 3.2 | IEQ Credit 4.6 | IEQ Credit 8.1 | IEQ Credit 9
17. Manufacturer, subject to compliance with USG Boral ME terms & Conditions
18. Available in black color for operating theaters, cinemas
19. Product Name [Halcyon™]

HALCYON™ HEALTHCARE

STANDARD SPECIFICATION



Features & Benefits:

- Water repellent membrane designed to be durable and safe with common disinfectants
- Fiber Glass substrate with monolithic visual reducing installation time
- Exceptional Sound Absorption with NRC values up to 1
- High Light Reflectance (LR-0.88) reduces light fixtures & Energy use
- Washable & Scrubbable finish
- Impact & Scratch Resistant
- Available in Plank Sizes compatible with Logix Integrated Ceiling System

Applications:

- Open-plan Areas
- Offices with indirect lighting
- Waiting Rooms, Nurses stations
- Media Rooms
- Receptions & Lobby Areas
- Libraries
- Convention halls and concourses

HALCYON™ HEALTHCARE SOUND ABSORPTION - 19 MM

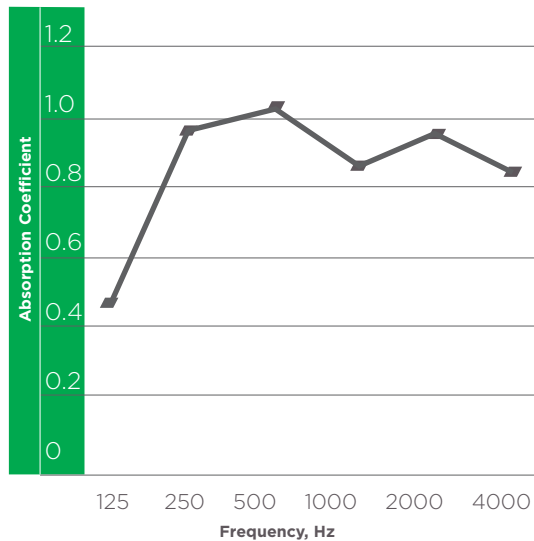

	Item	Size	Edge Detail	NRC	CAC	LR	Recycled Content	VOC Emission	Cost
☀️	HC669-HC HC229-HC	600*600*19 610*610*19	SQ	0.95	24	88%	40%	N/A	\$\$\$\$
☀️	HC629-HC HC249-HC	600*1200*19 610*1220*19	SQ	0.95	24	88%	40%	N/A	\$\$\$\$
☀️	HC6625-HC HC2225-HC	600*600*25 610*610*25	SQ	1	25	88%	40%	N/A	\$\$\$\$
☀️	HC6225-HC HC2425-HC	600*1200*25 610*1220*25	SQ	1	25	88%	40%	N/A	\$\$\$\$
☀️	HC6638-HC HC2238-HC	600*600*38 610*610*38	SQ	1	31	88%	43%	N/A	\$\$\$\$
☀️	HC6238-HC HC2238-HC	600*1220*38 610*1220*38	SQ	1	31	88%	43%	N/A	\$\$\$\$
☀️	HCRF6625-HC HCRF2225-HC	600*600*25 610*610*25	FL	0.95	28	88%	40%	N/A	\$\$\$\$
☀️	HCRF6225-HC HCRF2425-HC	600*1200*25 610*1220*25	FL	0.95	28	88%	40%	N/A	\$\$\$\$

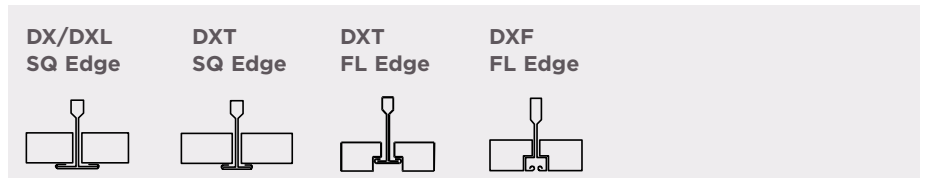

PART 2- PRODUCT

Product Specification Details | Acoustical Ceilings | 09 51 13

2.1 General

Provide Acoustical Ceiling Material manufactured to meet requirements of this specification in accordance with ASTM E 1264.

2.2 Materials

Acoustical Ceiling Units:

1. Type XII, Form 2, Pattern [E] [G]
2. Fiber Glass Substrate finished with Painted Fiber Glass scrim
3. Size 19, 25, 38 mm thick [600 x 600] [600 x 1200] [300 x 1200] [300 x 1500] [600 x 1500]
4. Edge Detail Trim (Square), Reveal (SL)(FL)
5. Noise Reduction Coefficient (NRC) [0.85][0.95][1]
6. Ceiling Attenuation Class (CAC) [24-30 dB]
7. Light Reflectance Coefficient (LR) 0.88
8. Recycled Content up to [43%]
9. Color White similar to RAL 9016
10. Surface Burning Characteristics per ASTM E84 Class A, Flame Spread:25, Smoke development: 15
11. Thermal Resistance: 0.6 m² °K/W - R 3.5 (19mm), 0.74 m² °K/W - R 4.2 (25mm)
12. Humidity Resistance Maximum 99% RH / 40°C, ClimaPlus
13. Weight 2.1 kg/m² for 19mm, 2.4 kg/m² for 25mm
14. Mold Prevention: Fiberglass substrate is inherently resistant to the growth of mold and mildew
15. Washability / Scrubbability: Exceeds 1000 Wash/Scrub Cycles without surface break or the extent of abrasion per ASTM D4828 & D2486
16. Water repellent application on Top surface up to 5 Hours
17. Relevant LEED Credit: EA Credit 1 | MR Credit 4| MR Credit 5 | MR Credit 6 IEQ Credit 3 | IEQ Credit 3.2 | IEQ Credit 4.6 | IEQ Credit 8.1 | IEQ Credit 9
18. Manufacturer, subject to compliance with USG Boral ME terms & Conditions 19. Product Name [Halcyon™ HealthCare]

LOGIX™

[SONATA | HALCYON™ | MARS™] PLANKS

STANDARD SPECIFICATION



Features & Benefits:

- Turn your ceiling's lighting and utilities into stunning design elements by integrating them into your ceiling plan with this system
- Monolithic, structured ceiling visual using standard components, available in Mineral Fiber (Sonata & Mars™), Fiber Glass (Halcyon™), Metal Substrate (Panz™) and Wood
- Designed to be compatible with a wide selection of 4", 6" and 12" utilities and in various module size
- Exceptional Sound Absorption with NRC values up to 1 for Thick Halcyon products
- High light-reflective finish reduces light fixtures and energy use
- Washable & Scrubbable finish
- Impact & Scratch Resistant
- The Logix system is available in two Configurations:
 - Logix Linear positions bands between main tees
 - Logix Basic (or perpendicular) channels intersect main tees.

Applications:

- Open-plan Offices
- Space with indirect lighting or natural Lighting
- Conference Rooms
- Media centers and Libraries
- Receptions & Lobby Areas
- Airport



		Item	Size	Edge Detail	NRC	CAC	LR	Recycled Content	VOC Emission	Cost
SONATA™ PLANKS		SC359	300*1500*19	SQ	0.7	37	89%	83%	Low	\$\$\$\$
		SC159	310*1520*19							
		SCRF689	600*1800*19	FLB	0.7	37	89%	83%	Low	\$\$\$\$
		SCRF289	610*1820*19							
HALCYON™ PLANKS		HC359	300*1500*19	SQ	0.95	24	89%	40%	N/A	\$\$\$\$
		HC159	310*1520*19							
		HC689	600*1800*19	SQ	0.95	24	89%	40%	N/A	\$\$\$\$
		HC289	610*1820*19							
		HCR6825	600*1800*25	SL	0.95	28	89%	41%	N/A	\$\$\$\$
HCR62425		600*2400*25								
MARS™ PLANKS		86221	610*1520*19	SQ	0.7	35	89%	77%	Low	\$\$\$\$
		86350	610*1520*22		0.8					
		86161	610*1520*19	SL	0.7	35	89%	77%	Low	\$\$\$\$
89650		610*1520*22		0.8						
	88984	610*1520*19	FLB	0.7	35	89%	77%	Low	\$\$\$\$	
	89550	610*1520*22		0.8						

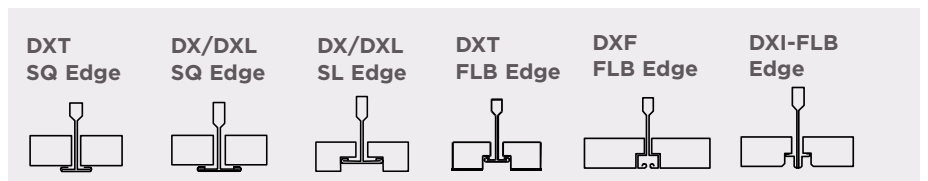

PART 2- PRODUCT

Product Specification Details | Acoustical Ceilings | 09 51 13

2.1 General

Provide Acoustical Ceiling Material manufactured to meet requirements of this specification in accordance with ASTM E 1264.

2.2 Materials

Acoustical Ceiling Units:

1. Type IV, XII, Form 1&2, Pattern [E,G]
2. Mineral or Fiber Glass Substrate finished with Painted Fiber Glass scrim
3. Size 19, 22, 25 mm thick [300 x 1500] [600 x 1500] [600 x 1800] [600 x 2400]
4. Edge Detail Trim (Square), Reveal (SL)(FL)
5. Noise Reduction Coefficient (NRC) [0.7][0.85][0.95][1]
6. Ceiling Attenuation Class (CAC) [20-24 dB] [35-37 dB]
7. Light Reflectance Coefficient (LR) [0.89]
8. Recycled Content [40%] [77%] [83%]
9. Color White similar to RAL 9016
10. Surface Burning Characteristics per ASTM E84 Class A, Flame Spread:25, Smoke development: 50
11. Thermal Resistance: Mars™ R 2.2; Halcyon™ 0.6 m² °K/W - R 3.5 (19mm), 0.74 m² °K/W - R 4.2 (25mm)
12. Humidity Resistance Maximum 95% RH / 40°C, ClimaPlus
13. Weight: Mars™ 5.2 kg/m² (19mm), 6 kg/m² (22mm) Halcyon™ 1.7 kg/m² for 15mm, 2.1 kg/m² for 19mm, 2.4 kg/m² for 25mm
14. Mold Prevention: Fiberglass substrate is inherently resistant to the growth of mold and mildew
15. Washability / Scrubbability: Exceeds 1000 Wash/Scrub Cycles without surface break or the extent of abrasion per ASTM D4828 & D2486
16. Relevant LEED Credit: EA Credit 1 | MR Credit 4| MR Credit 5 | MR Credit 6 IEQ Credit 3 | IEQ Credit 3.2 | IEQ Credit 4.6 | IEQ Credit 8.1 | IEQ Credit 9
17. Manufacturer, subject to compliance with USG Boral ME terms & Conditions
18. Product Name [LOGIX Planks]

LOUNA™

STANDARD SPECIFICATION



Features & Benefits:

- Soft Fiber substrate with monolithic visual reducing installation time
- Exceptional Sound Absorption with NRC values up to 1
- High Light Reflectance (LR-0.88) reduces light fixtures & Energy use
- Washable & Scrubbable finish
- Impact & Scratch Resistant
- Available in Plank Sizes compatible with Logix Integrated Ceiling System
- Non Combustible panels (Euro Class A1), with rockwool base material, exceptional Humidity Resistance up to 99% RH
- Ideal for use in cinemas & operating theaters

Applications:

- Open-plan Areas
- Offices with indirect lighting
- Media Rooms
- Receptions & Lobby Areas
- Libraries
- Convention halls and concourses
- Cinemas & operating theaters

LOUNA SOUND ABSORPTION

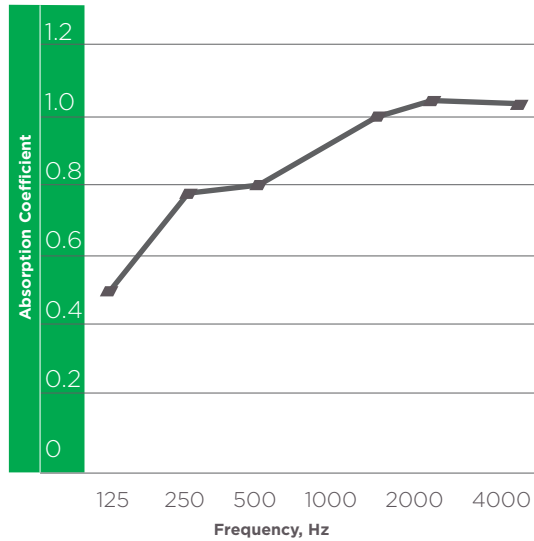

	Item	Size	Edge Detail	NRC	CAC	LR	Recycled Content	VOC Emission	Cost
	LC665 LC225	600*600*15 610*610*15	SQ	0.9	24	88%	40%	N/A	\$\$\$
	LC669 LC229	600*600*19 610*610*19	SQ	0.95	24	88%	40%	N/A	\$\$\$\$
	LC629 LC249	600*1200*19 610*1220*19	SQ	0.95	24	88%	40%	N/A	\$\$\$\$
	LC6625 LC2225	600*600*25 610*610*25	SQ	0.95	28	88%	40%	N/A	\$\$\$\$
	LC6225B LC2425B	600*1200*25 610*1220*25	SQ	0.9	28	-	40%	N/A	\$\$\$\$

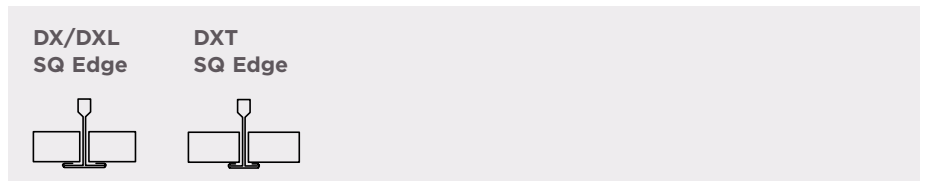

PART 2- PRODUCT

Product Specification Details | Acoustical Ceilings | 09 51 13

2.1 General

Provide Acoustical Ceiling Material manufactured to meet requirements of this specification in accordance with ASTM E 1264.

2.2 Materials

Acoustical Ceiling Units:

1. Type XII, Pattern [G]
2. Soft Fiber substrate finished with Fiber Glass scrim
3. Size 15, 19,25 mm thick [600 x 600] [600 x 1200]
4. Edge Detail Trim (Square)
5. Noise Reduction Coefficient (NRC) [0.9][0.95]
6. Ceiling Attenuation Class (CAC) [24-25 dB]
7. Light Reflectance Coefficient (LR) 0.88
8. Recycled Content [40%]
9. Color White similar to RAL 9016 and black similar to RAL 9005
10. Surface Burning Characteristics per ASTM E84 Class A, Flame Spread:10, Smoke development: 10 Reaction to Fire: Euroclass A1 in accordance with EN-13501-1
11. Thermal Resistance: 0.6 m² °K/W - R 3.5 (19mm), 0.74 m² °K/W - R 4.2 (25mm)
12. Humidity Resistance Maximum 99% RH / 40°C
13. Weight: 1.7 kg/m² for 15mm, 2.1 kg/m² for 19mm, 2.4 kg/m² for 25mm
14. Mold Prevention: Soft Fiber substrate is inherently resistant to the growth of mold and mildew
15. Washability / Scrubbability: Exceeds 1000 Wash/Scrub Cycles without surface break or the extent of abrasion per ASTM D4828 & D2486
16. Relevant LEED Credit: EA Credit 1 | MR Credit 4| MR Credit 5 | MR Credit 6 IEQ Credit 3 | IEQ Credit 3.2 | IEQ Credit 4.6 | IEQ Credit 8.1 | IEQ Credit 9
17. Manufacturer, subject to compliance with USG Boral ME terms & Conditions
18. Product Name [Louna]
19. Available in Black Color for Cinemas and Operating Theaters

LOUNA™ HI CAC

STANDARD SPECIFICATION



Features & Benefits:







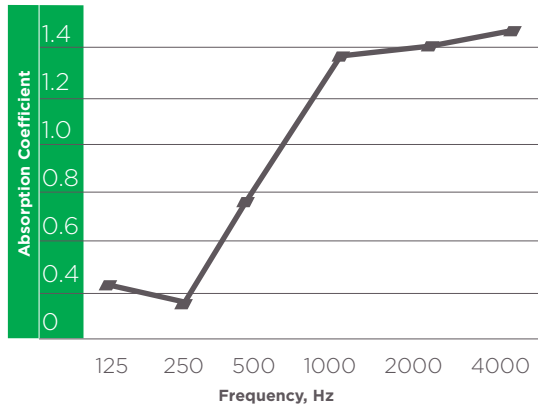

- Water repellent membrane designed to be durable and safe with common disinfectants
- Soft Fiber substrate and Wet Felted Mineral Fiber Substrate finished with Painted Fiber Glass scrim
- Exceptional Sound Absorption with NRC values up to 0.85 and CAC up to 42dB
- High Light Reflectance (LR-0.88) reduces light fixtures & Energy use
- Washable & Scrubbable finish
- Impact & Scratch Resistant
- Available in Plank Sizes compatible with Logix Integrated Ceiling System

Applications:

- Open-plan Areas
- Offices with indirect lighting
- Media Rooms
- Receptions & Lobby Areas & corridors
- Convention halls and concourses
- Cinemas, theaters

LOUNA HI CAC SOUND ABSORPTION



	Item	Size	Edge Detail	NRC	CAC	LR	Recycled Content	VOC Emission	Cost
	LCX6643-MF LCX2243-MF	600*600*43 610*610*43	SQ	0.85	42	88%	40%	N/A	\$\$\$\$
	LCX6243-MF LCX2443-MF	600*1200*43 610*1220*43	SQ	0.85	42	88%	40%	N/A	\$\$\$\$
	LCX6643B-MF LCX2243B-MF	600*600*43 610*1220*43	SQ	0.85	42	-	41%	N/A	\$\$\$\$
	LCX6243B-MF LCX2443B-MF	600*1200*43 600*1220*43	SQ	0.85	42	-	41%	N/A	\$\$\$\$
	LCXRF6643-MF LCXRF2243-MF	600*600*43 610*610*43	FL	0.85	42	88%	40%	N/A	\$\$\$\$
	LCXRF6243-MF LCXRF2443-MF	600*1200*43 610*1220*43	FL	0.85	42	88%	40%	N/A	\$\$\$\$
	LCXRF6643B-MF LCXRF2243B-MF	600*600*43 610*610*43	FL	0.85	42	-	41%	N/A	\$\$\$\$
	LCXRF6243B-MF LCXRF2443B-MF	600*1200*43 600*1220*43	FL	0.85	42	-	41%	N/A	\$\$\$\$

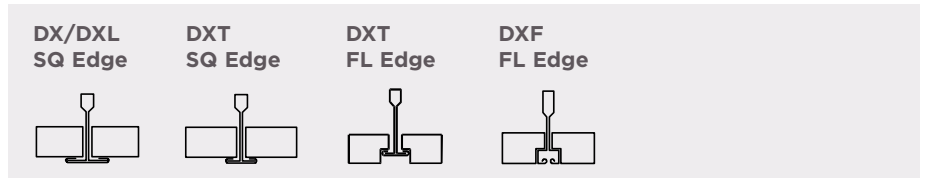

PART 2- PRODUCT

Product Specification Details | Acoustical Ceilings | 09 51 13

2.1 General

Provide Acoustical Ceiling Material manufactured to meet requirements of this specification in accordance with ASTM E 1264.

2.2 Materials

Acoustical Ceiling Units:

1. Type XII, Form 2, Pattern [G]
2. Soft Fiber substrate and Wet Felted Mineral Fiber Substrate finished with Painted Fiber Glass scrim
3. Size 43 mm thick [600 x 600] [600 x 1200] [300 x 1200] [600 x 1500] [600 x 1800]
4. Edge Detail Trim (Square), Reveal (FL)
5. Noise Reduction Coefficient (NRC) [0.85]
6. Ceiling Attenuation Class (CAC) [40-42 dB]
7. Light Reflectance Coefficient (LR) 0.88
8. Recycled Content [40%]
9. Color White similar to RAL 9016 and Black similar to RAL 9005
10. Surface Burning Characteristics per ASTM E84 Class A, Flame Spread:25, Smoke development: 50
11. Thermal Resistance: 0.6 m² °K/W - R 3.5 (19mm), 0.74 m² °K/W - R 4.2 (25mm)
12. Humidity Resistance Maximum 99% RH / 40°C, ClimaPlus
13. Weight: 6.25 kg/m² for White 43mm and 7.5 kg/m² for Black 43mm
14. Mold Prevention: Soft Fiber substrate is inherently resistant to the growth of mold and mildew
15. Washability / Scrubbability: Exceeds 1000 Wash/Scrub Cycles without surface break or the extent of abrasion per ASTM D4828 & D2486
16. Relevant LEED Credit: EA Credit 1 | MR Credit 4| MR Credit 5 | MR Credit 6 IEQ Credit 3 IEQ Credit 3.2 | IEQ Credit 4.6 | IEQ Credit 8.1 | IEQ Credit 9
17. Manufacturer, subject to compliance with USG Boral ME terms & Conditions
18. Product Name [Louna Hi CAC]

MARS™

STANDARD SPECIFICATION



Features & Benefits:







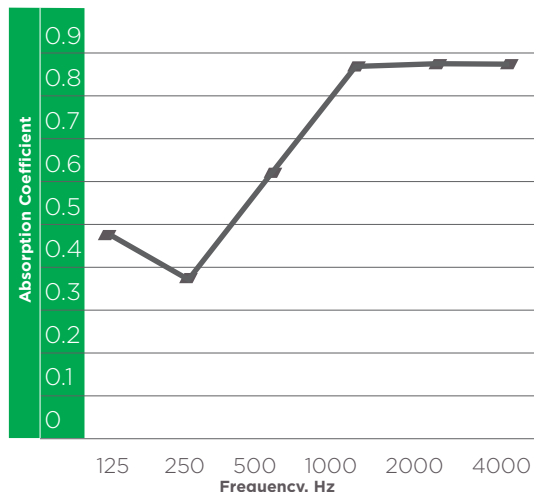

- Due to numerous properties, it is convenient for multiple usage in HealthCare application and Open Plan Offices
- Non-directional, monolithic visual which reduces installation time and offers Industry's highest light reflectance LR 0.89 to reduce light fixtures and energy use as a part of Indirect lighting
- Washable and scrubbable finish resistance, impact and scratch resistant for a durable and cleanable surface
- Mars HealthCare features with Water repellent membrane designed to be durable and safe with common disinfectants
- Available in High NRC formulation up to 0.8 and in optimized recycled content formulations to help maximize LEED recycled content contribution
- Acoustics and cleanability exceed FGI guidelines for healthcare applications and Achieves FDA standards for smoothness, durability and cleanability. It assists also in addressing HIPPA standards for sound control in healthcare facilities
- ClimaPlus 30-year lifetime system warranty against visible sag, mold and mildew
- Meets USDA/FSIS guidelines for use in food processing areas
- Available in Plank size, FLB edges compatible with Logix Integrated Ceiling System

Applications:

- Healthcare: Patient Rooms, Treatment rooms, Nurses' station, Waiting Rooms, Laboratories, Corridors, Lavatories & Restrooms, Kitchen/food preparation area
- Executive Offices and Conference rooms
- Reception areas and Lobbies
- Classrooms
- Corridors
- Dining rooms, kitchens and food preparation area

MARS SOUND ABSORPTION



	Item	Size	Edge Detail	NRC	CAC	LR	Recycled Content	VOC Emission	Cost
	 86185 88185	610*610*19 610*1220*19	SQ	0.7	35	89%	76%	Low	\$\$\$\$
	 86785 88785	610*610*19 610*1220*19	SLT	0.7	35	89%	76%	Low	\$\$\$\$
MARS™ HIGH NRC	 86985 88985	610*610*19 610*1220*19	FLB	0.7	35	89%	76%	Low	\$\$\$\$
	 86100 86300	610*610*22 610*1220*22	SQ	0.8	35	89%	77%	Low	\$\$\$\$
	 87200 89600	610*610*22 610*1220*22	SLT	0.8	35	89%	77%	Low	\$\$\$\$
	 87100 89500	610*610*22 610*1220*22	FLB	0.8	35	89%	77%	Low	\$\$\$\$
PLANKS	 86221 86350	610*1520*19 610*1520*22	SQ	0.7 0.8	35	89%	77%	Low	\$\$\$\$
	 86161 89650	610*1520*19 610*1520*22	SLT	0.7 0.8	35	89%	77%	Low	\$\$\$\$
	 88984 89550	610*1520*19 610*1520*22	FLB	0.7 0.8	35	89%	77%	Low	\$\$\$\$

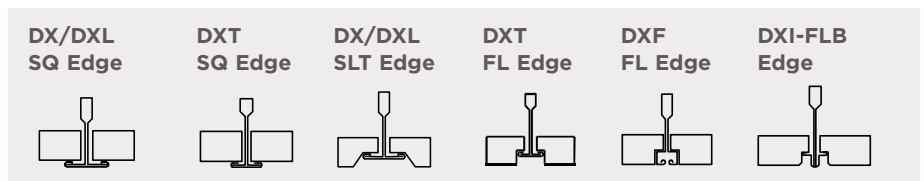

PART 2- PRODUCT

Product Specification Details | Acoustical Ceilings | 09 51 13

2.1 General

Provide Acoustical Ceiling Material manufactured to meet requirements of this specification in accordance with ASTM E 1264.

2.2 Materials

Acoustical Ceiling Units:

1. Type IV, Form 1&2, Pattern [E] [G]
2. Mineral Fiber Substrate manufactured in wet Felted and X Technologies and finished with Painted Fiber Glass scrim
3. Size 19,22 mm thick [600 x 600] [600 x 1200] [600 x 1500] [600 x 1800]
4. Edge Detail Trim (Square), Reveal (SLT) (FLB)
5. Noise Reduction Coefficient (NRC) [0.7] [0.8]
6. Ceiling Attenuation Class (CAC) [35 dB]
7. Light Reflectance Coefficient (LR) 0.89
8. Recycled Content [up to 80.5% for HRC]
9. Color White similar to RAL 9016
10. Surface Burning Characteristics per ASTM E84 Class A, Flame Spread:25, Smoke development:50
11. Thermal Resistance: R 2.2
12. Humidity Resistance Maximum 95% RH / 40°C
13. Weight: 5.2 kg/m² (19mm), 6 kg/m² (22mm)
14. Mold Prevention application per ASTM D3273-1, Rate 10 per D3274
15. Washability / Scrubbability: Exceeds 1000 Wash/Scrub Cycles without surface break or the extent of abrasion per ASTM D4828 & D2486
16. Available in water repellency on the finished surface for Healthcare applications under [Mars Healthcare]
17. Relevant LEED Credit: EA Credit 1 | MR Credit 4 | MR Credit 5 | MR Credit 6 IEQ Credit 3 | IEQ Credit 3.2 | IEQ Credit 4.6 | IEQ Credit 8.1 | IEQ Credit 9
18. Manufacturer, subject to compliance with USG Boral ME terms & Conditions
19. Product Name [Mars]

METAL FACE

STANDARD SPECIFICATION

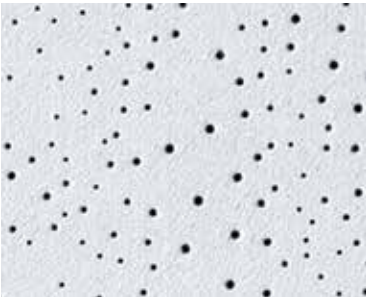

Features & Benefits:



- Have an embossed, rigid White vinyl-laminated face Aluminum foil backed capable to pass all fire testing requirement per UL 723
- Made with Fire code base materials to meet life safety codes
- Coordinates visually with Clean Room perforated finish Class 10M-100M panels used in non-restricted areas in lobbies, waiting rooms and corridors to meet acoustical requirements in hospitals
- Classified HRC panels (High Recycled Content) which is greater than 50%
- Due to its acoustic performance it is suitable for use in certain areas for Patient care such as pharmacy, central services, laboratories, patient rooms, nurse's stations, storage areas and nurseries
- It offers extra resistance to corrosion, soiling, humidity and chlorine vapors
- Washable, scrubbable resistance
- High humidity resistant and anti-mold, mildew growth
- Available in Plank sizes

Applications:

- HIGH Humidity Areas
- Laboratories/pharmacies
- Nurseries
- Corridors/Lobbies
- Certain Patient Care area - Waiting rooms
- Offices

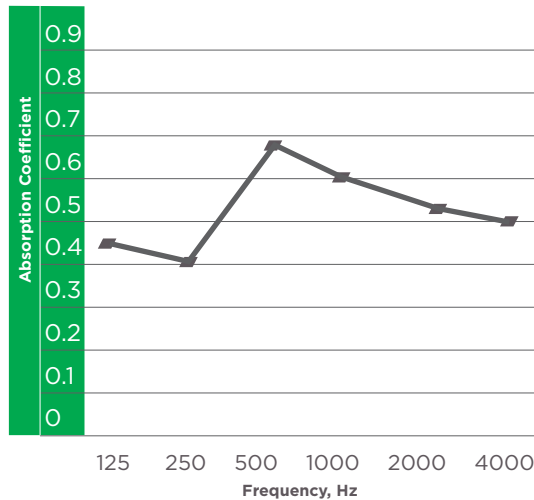
METAL FACE SOUND ABSORPTION - 16 MM



	Item	Size	Edge Detail	NRC	CAC	LR	Recycled Content	VOC Emission	Cost
	MCX666	600*600*16	SQ	0.55	37	80%	52%	N/A	\$\$\$\$
	MCX226	610*610*16							
	MCX626	600*1200*16	SQ	0.55	37	80%	52%	N/A	\$\$\$\$
	MCX246	610*1220*16							

DX/DXL
SQ Edge



PART 2- PRODUCT

Product Specification Details | Acoustical Ceilings | 09 51 13

2.1 General

Provide Acoustical Ceiling Material manufactured to meet requirements of this specification in accordance with ASTM E 1264 and EN 13964.

2.2 Materials

Acoustical Ceiling Units:

1. Type X, Pattern [B] [C] [I]
2. Embossed Perforated Vinyl-faced baked with Aluminum Foil for fire resistance
3. Size 16mm thick [600 x 600] [600 x 1200]
4. Edge Detail Trim (Square)
5. Noise Reduction Coefficient (NRC) [0.55]
6. Ceiling Attenuation Class (CAC) [37 dB]
7. Light Reflectance Coefficient (LR) 0.8
8. Recycled Content [52%]
9. Color White
10. Surface Burning Characteristics per ASTM E 84 Class A, Flame Spread: 10, Smoke development: 20 Reaction to Fire: Euroclass A2-s1,d0 in accordance with EN-13501-1
11. Underwriters Laboratories Inc. Fire-Resistance (ASTM E 119) ANSI/UL 263 Time-Rated Assembly [3hrs] [D218]
12. Thermal Resistance: 0.23 m² °K/W - R 1.3 (15mm)
13. Humidity Resistance Maximum 99% RH / 40°C
14. Weight: 5.25 kg/m²
15. Relevant LEED Credit: EA Credit 1 | MR Credit 4| MR Credit 5 | MR Credit 6 IEQ Credit 3 | IEQ Credit 3.2 | IEQ Credit 4.6 | IEQ Credit 8.1 | IEQ Credit 9
16. Manufacturer, subject to compliance with USG Boral ME terms & Conditions
17. Product Name [Metal Face]

OLYMPIA II™

STANDARD SPECIFICATION



Features & Benefits:

Finely granulated surface texture

- High light reflectance finish (LR-0.89) reduces light fixtures & energy use
- Economical, non-directional pattern reduces installation time and waste
- Fire resistant system options, for life safety and protection of property
- Available also in ClimaPlus Formulation for 99% Humidity Resistance and various Plank Sizes

Applications:

- Reception
- Commercial Stores
- Libraries
- Banks
- Fitness Rooms
- Corridors/Stairwell
- Waiting Area
- Nursery
- Retail Stores



	Item	Size	Edge Detail	NRC	CAC	LR	Recycled Content	VOC Emission	Cost
	OLS665N	600*600*15	SQ	0.15	33	89%	32%	Low	\$
	OLS225N	610*610*15							
	OLSR665N	600*600*15	SLT	0.15	33	89%	32%	Low	\$
	OLSR225N	610*610*15							
	OLSRF665N	600*600*15	FLB	0.15	33	89%	32%	Low	\$
	OLSRF225N	610*610*15							
	OLC665N	600*600*15	SQ	0.15	33	89%	39%	Low	\$
	OLC225N	610*610*15							
	OLC625N	600*1200*15	SQ	0.15	33	89%	39%	Low	\$
	OLC245N	610*1220*15							
	OLCR665N	600*600*15	SLT	0.15	33	89%	39%	Low	\$
	OLCR225N	610*610*15							
	OLCRF665N	600*600*15	FLB	0.15	33	89%	39%	Low	\$
	OLCRF225N	610*610*15							
	OLX665N	600*600*15	SQ	0.15	35	89%	46%	Low	\$\$
	OLX225N	610*610*15							
PLANKS	OLC325N	300*1200*15	SQ	0.15	35	89%	39%	Low	\$\$\$
	OLC145N	310*1220*15							
	OLCR325N	300*1200*15	SLT	0.15	35	89%	39%	Low	\$\$\$
	OLCR145N	310*1220*15							
	OLCRF325N	300*1200*15	FLB	0.15	35	89%	39%	Low	\$\$\$
OLCRF145N	310*1220*15								
	OLS669N	600*600*19	SQ	0.15	35	89%	32%	Low	\$\$\$
	OLS229N	610*610*19							
	OLSR669N	600*600*19	SLT	0.15	35	89%	32%	Low	\$\$\$
	OLSR229N	610*610*19							
	OLSRF669N	600*600*19	FLB	0.15	35	89%	32%	Low	\$\$\$
	OLSRF229N	610*610*19							
	OLC669N	600*600*19	SQ	0.15	35	89%	39%	Low	\$\$\$
	OLC229N	610*610*19							
	OLC629N	600*1200*19	SLT	0.15	35	89%	39%	Low	\$\$\$
	OLC249N	610*1220*19							
	OLCR629N	600*1200*19	SLT	0.15	35	89%	39%	Low	\$\$\$
OLCR245N	610*1220*19								
OLCRF629N	600*1200*19	FLB	0.15	35	89%	39%	Low	\$\$\$	
OLCRF249N	610*1220*19								
PLANKS	OLC359N	300*1500*19	SQ	0.15	35	89%	39%	Low	\$\$\$\$
	OLC159N	310*1520*19							



OLYMPIA II™

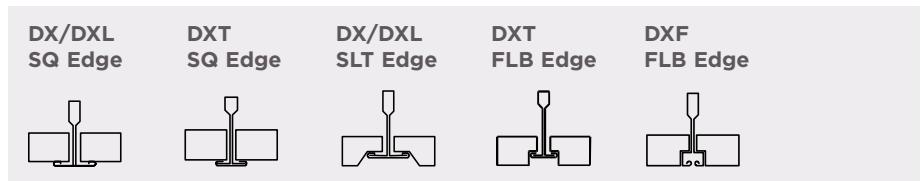

PART 2- PRODUCT

Product Specification Details | Acoustical Ceilings | 09 51 13

2.1 General

Provide Acoustical Ceiling Material manufactured to meet requirements of this specification in accordance with ASTM E 1264 and EN 13964.

2.2 Materials

Acoustical Ceiling Units:

1. Type III, Form 2, Pattern [E]
2. Fine sand textured panels
3. Size 15, 19 mm thick [600 x 600] [600 x 1200] [300 x 1200] [300 x 1500]
4. Edge Detail Trim (Square), Reveal (SLT) (FLB)
5. Noise Reduction Coefficient (NRC) [0.15]
6. Ceiling Attenuation Class (CAC) [33-35 dB]
7. Light Reflectance Coefficient (LR) 0.89
8. Recycled Content [32 - 46%]
9. Color White similar to RAL 9016
10. Surface Burning Characteristics per ASTM E 84 Class A, Flame Spread: 10, Smoke development: 20 Reaction to Fire: Euroclass A2-s1,d0 in accordance with EN-13501-1
11. Underwriters Laboratories Inc. Fire-Resistance (ASTM E 119) ANSI/UL 263 Time-Rated Assembly [2hrs] [J201]
12. Thermal Resistance: 0.23 m² °K/W - R 1.3 (15mm), 0.31 m² °K/W - R 1.8 (19mm)
13. Humidity Resistance Maximum 99% RH / 40°C for ClimaPlus
14. Weight: 3.85 kg/m² (Regular / ClimaPlus) 15mm, 5.25 kg/m² (Fire code) 15mm, 4.85 kg/m² (Regular / ClimaPlus) 19mm, 7.15 kg/m² (Fire code) 19mm
15. Mold Prevention application available upon request per ASTM D3273-1, Rate 10 per D3274
16. Relevant LEED Credit: EA Credit 1 | MR Credit 4 | MR Credit 5 | MR Credit 6 | IEQ Credit 3 | IEQ Credit 3.2 | IEQ Credit 4.6 | IEQ Credit 8.1 | IEQ Credit 9
17. Manufacturer, subject to compliance with USG Boral ME terms & Conditions
18. Product Name [Olympia II™]

OLYMPIA MICRO™

STANDARD SPECIFICATION



Features & Benefits:

- Offers a balance of acoustic performance, fire reaction, fire resistance, 95% Humidity Resistance and 89% Light Reflectance
- Light granulated surface texture with virtually invisible micro-perforation for a smoother look than standard perforations that improve sound absorption
- High light reflectance finish (LR-0.89) reduces light fixtures and energy use
- Fire resistant system options, for life safety and protection of property
- Available in HRC (High Recycled Content) for optimized recycled content formulations to help maximize LEED recycled content contribution
- Available also in ClimaPlus Formulation for 99% Humidity Resistance and for various edge details
- Ideal solutions for classroom and general teaching conditions
- Treated when requested on panels face and back surfaces with a patented, broad-spectrum antimicrobial standard formulation that inhibit mold growth

Applications:

- Classrooms
- Libraries
- Corridors/Stairwell
- Reception and Lobby areas
- Cafeteria/Restaurant
- Sports hall
- General Offices
- Shopping Centers

OLYMPIA MICRO™ SOUND ABSORPTION

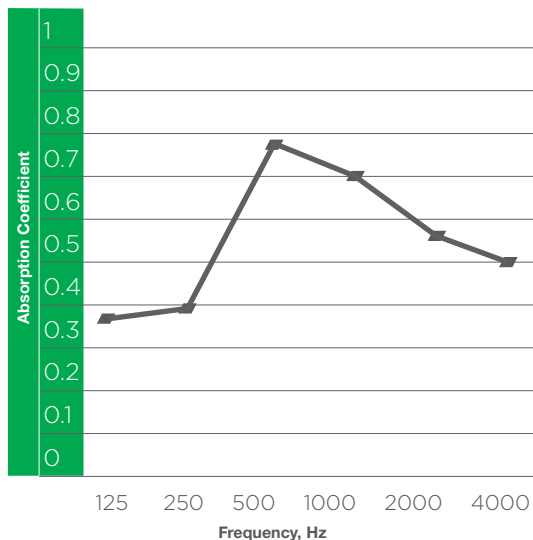

		Item	Size	Edge Detail	NRC	CAC	LR	Recycled Content	VOC Emission	Cost	
		OLPS665N OLPS225N	600*600*15 610*610*15	SQ	0.55	35	89%	32%	Low	\$	
		OLPSR665N OLPSR225N	600*600*15 610*610*15	SLT	0.55	35	89%	32%	Low	\$	
		OLPSRF665N OLPSRF225N	600*600*15 610*610*15	FLB	0.55	35	89%	32%	Low	\$	
		OLPC665N OLPC225N	600*600*15 610*610*15	SQ	0.55	35	89%	39%	Low	\$	
		OLPC625N OLPC245N	600*1200*15 610*1220*15	SQ	0.55	35	89%	39%	Low	\$	
		OLPCR665N OLPCR225N	600*600*15 610*610*15	SLT	0.55	35	89%	39%	Low	\$	
		OLPCRF665N OLPCRF225N	600*600*15 610*610*15	FLB	0.55	35	89%	39%	Low	\$	
		OLPX665N OLPX225N	600*600*15 610*610*15	SQ	0.55	35	89%	46%	Low	\$\$	
		OLPX625N OLPX245N	600*1200*15 610*1220*15	SQ	0.55	35	89%	46%	Low	\$\$	
	PLANKS		OLPC325N OLPC145N	300*1200*15 310*1220*15	SQ	0.55	35	89%	39%	Low	\$\$\$
			OLPCR325N OLPCR145N	300*1200*15 310*1220*15	SLT	0.55	35	89%	39%	Low	\$\$\$
			OLPCRF325N OLPCRF145N	300*1200*15 310*1220*15	FLB	0.55	35	89%	39%	Low	\$\$\$
			OLPS669N OLPS229N	600*600*19 610*610*19	SQ	0.65	37	89%	32%	Low	\$\$\$
			OLPSR669N OLPSR229N	600*600*19 610*610*19	SLT	0.65	37	89%	32%	Low	\$\$\$
			OLPSRF669N OLPSRF229N	600*600*19 610*610*19	FLB	0.65	37	89%	32%	Low	\$\$\$
			OLPC669HNRC OLPC229HNRC	600*600*19 610*610*19	SQ	0.7	37	89%	82%	Low	\$\$\$
		OLPCR669HNRC OLPCR229HNRC	600*600*19 610*610*19	SLT	0.7	37	89%	82%	Low	\$\$\$	
		OLPCRF669HNRC OLPCRF229HNRC	600*600*19 610*610*19	FLB	0.7	37	89%	82%	Low	\$\$\$	
		OLPC629HNRC OLPC249HNRC	600*1200*19 610*1220*19	SLT	0.7	37	89%	82%	Low	\$\$\$	
		OLPCR629HNRC OLPCR245HNRC	600*1200*19 610*1220*19	SLT	0.7	37	89%	82%	Low	\$\$\$	
		OLPCRF629HNRC OLPCRF249HNRC	600*1200*19 610*1220*19	FLB	0.7	37	89%	82%	Low	\$\$\$	
PLANKS			OLPC329N OLPC349N	300*1200*19 310*1220*19	SQ	0.7	35	89%	82%	Low	\$\$\$
			OLPCR329N OLPCR349N	300*1200*19 310*1220*19	SLT	0.7	35	89%	82%	Low	\$\$\$
			OLPCRF329N OLPCRF349N	300*1200*19 310*1220*19	FLB	0.7	35	89%	82%	Low	\$\$\$



OLYMPIA MICRO™

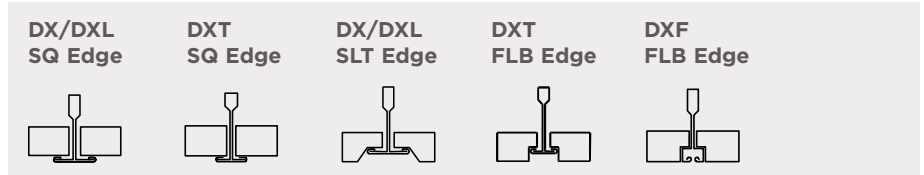

PART 2- PRODUCT

Product Specification Details | Acoustical Ceilings | 09 51 13

2.1 General

Provide Acoustical Ceiling Material manufactured to meet requirements of this specification in accordance with ASTM E 1264 and EN 13964.

2.2 Materials

Acoustical Ceiling Units:

1. Type III, Form 2, Pattern [C,E]
2. Fine sand textured panels
3. Size 15, 19 mm thick [600 x 600] [600 x 1200] [300 x 1200]
4. Edge Detail Trim (Square), Reveal (SLT) (FLB)
5. Noise Reduction Coefficient (NRC) [0.55] [0.65] [0.7]
6. Ceiling Attenuation Class (CAC) [35-37 dB]
7. Light Reflectance Coefficient (LR) 0.89
8. Recycled Content [up to 82%]
9. Color White similar to RAL 9016
10. Surface Burning Characteristics per ASTM E 84 Class A, Flame Spread: 10, Smoke development: 20 Reaction to Fire: Euroclass A2-s1,d0 in accordance with EN-13501-1
11. Underwriters Laboratories Inc. Fire-Resistance (ASTM E 119) ANSI/UL 263 Time-Rated Assembly [2hrs] [J201]
12. Thermal Resistance: 0.23 m² °K/W - R 1.3 (15mm), 0.31 m² °K/W - R 1.8 (19mm)
13. Humidity Resistance Maximum 99% RH / 40°C for ClimaPlus
14. Weight: 3.85 kg/m² (Regular / ClimaPlus) 15mm, 5.25 kg/m² (Fire code) 15mm, 4.85 kg/m² (Regular / ClimaPlus) 19mm, 7.15 kg/m² (Fire code) 19mm
15. Mold Prevention application available upon request per ASTM D3273-1, Rate 10 per D3274
16. Relevant LEED Credit: EA Credit 1 | MR Credit 4 | MR Credit 5 | MR Credit 6 | IEQ Credit 3 | IEQ Credit 3.2 | IEQ Credit 4.6 | IEQ Credit 8.1 | IEQ Credit 9
17. Manufacturer, subject to compliance with USG Boral ME terms & Conditions
18. Product Name [Olympia Micro™]

OMNI

STANDARD SPECIFICATION

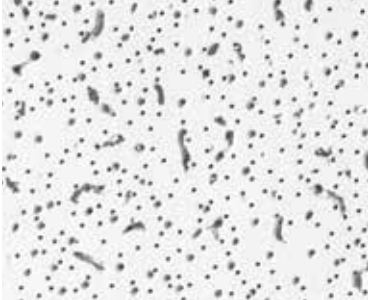

Features & Benefits:

- It provides a very economical cost with a wide variety of panel option to meet various application
- Medium-textured panels that feature a unique, non-directional pattern with a fresh, clean appearance offers fast, efficient installation
- Optional FIRECODE™ formulation designed to meet life safety codes
- Available in Washable paint for easy maintenance using soft brush or vacuum to clean the surface
- Mid-range sound absorption and sound attenuation which make it ideal for general commercial stores

Applications:

- Grocery Stores
- Corridors/Hallways
- Warehouses
- Mechanical Rooms
- Stairways/Elevator Shafts



Item	Size	Edge Detail	NRC	CAC	LR	Recycled Content	VOC Emission	Cost
OMS665	600*600*15	SQ	0.5	35	82%	32%	Low	\$
OMS225	610*610*15							
OMSR665	600*600*15	SLT	0.5	35	82%	32%	Low	\$
OMSR225	610*610*15							
OMC625W	600*1200*15	SQ	0.5	35	82%	32%	Low	\$\$
OMC245W	610*1220*15							
OMX665	600*600*15	SQ	0.5	35	82%	46%	Low	\$\$
OMX225	610*610*15							
OMS669	600*600*19	SQ	0.6	37	82%	32%	Low	\$\$
OMS229	610*610*19							
OMX669	600*600*19	SQ	0.6	37	82%	32%	Low	\$\$\$
OMX229	610*610*19							

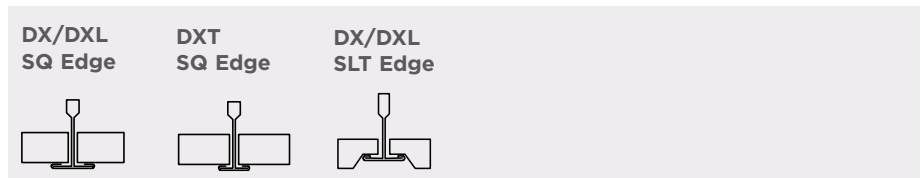

PART 2- PRODUCT

Product Specification Details | Acoustical Ceilings | 09 51 13

2.1 General

Provide Acoustical Ceiling Material manufactured to meet requirements of this specification in accordance with ASTM E 1264 and EN 13964.

2.2 Materials

Acoustical Ceiling Units:

1. Type III, Form 2, Pattern [C] [D] [E]
2. Fine non-directional fissured panel
3. Size 15,19 mm thick [600 x 600] [600 x 1200]
4. Edge Detail Trim (Square), Reveal (SLT)
5. Noise Reduction Coefficient (NRC) [0.5] [0.6]
6. Ceiling Attenuation Class (CAC) [35-37 dB]
7. Light Reflectance Coefficient (LR) 0.82
8. Recycled Content [32%] [46%]
9. Color White similar to RAL 9016
10. Surface Burning Characteristics per ASTM E 84 Class A, Flame Spread: 10, Smoke development: 20 Reaction to Fire: Euroclass A2-s1,d0 in accordance with EN-13501-1
11. Underwriters Laboratories Inc. Fire-Resistance (ASTM E 119) ANSI/UL 263 Time-Rated Assembly [2hrs] [J201]
12. Thermal Resistance: 0.23 m² °K/W - R 1.3 (15mm), 0.31 m² °K/W - R 1.8 (19mm)
13. Humidity Resistance Maximum 95% RH / 40°C
14. Weight: 3.55 kg/m² (Regular / ClimaPlus) 15mm, 5 kg/m² (Fire code) 15mm, 4.5 kg/m² (Regular / ClimaPlus) 19mm, 6.85 kg/m² (Fire code) 19mm
15. Washability / Scrubbability: Exceeds 1000 Wash/Scrub Cycles without surface break or the extent of abrasion per ASTM D4828 & D2486
16. Mold Prevention application available upon request per ASTM D3273-1, Rate 10 per D3274
17. Relevant LEED Credit: EA Credit 1 | MR Credit 4| MR Credit 5 | MR Credit 6 IEQ Credit 3 | IEQ Credit 3.2 | IEQ Credit 4.6 | IEQ Credit 8.1 | IEQ Credit 9
18. Manufacturer, subject to compliance with USG Boral ME terms & Conditions
19. Product Name [Omni]

PEDESTAL

STANDARD SPECIFICATION





Features & Benefits:

- Triple stepped face cuts adds depth and proportion to the ceiling
- Pedestals I, the look of 600 x 600 mm tiles
- Contemporary non perforated plain or textured
- Mid-range sound attenuation, ideal for general commercial construction
- Easy to install and cut
- Clean look for a rich looking ceiling

Applications:

- Education
- Healthcare
- Hotels
- Leisure
- Office
- Retail



Item	Size	Edge Detail	NRC	CAC	LR	Recycled Content	VOC Emission	Cost
 DP1C669 DP1C229	600*600*19	ILT	0.15	35	86%	32%	Low	\$\$
	610*610*19							
 DP1OLCRI669 DP1OLCRI229	600*600*19	ILT	0.15	35	88%	39%	Low	\$\$\$
	610*610*19							

DXT PE/SLT
Edge 3/4"

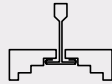

PART 2- PRODUCT

Product Specification Details | Acoustical Ceilings | 09 51 13

2.1 General

Provide Acoustical Ceiling Material manufactured to meet requirements of this specification in accordance with ASTM E 1264 and EM 13964.

2.2 Materials

Acoustical Ceiling Units:

1. Type III, Form 2, Pattern [E] [G]
2. Plain textured stepped face cut
3. Panels Size 19mm thick [600 x 600]
4. Edge Detail Reveal (ILT)
5. Noise Reduction Coefficient (NRC) [0.15]
6. Ceiling Attenuation Class (CAC) [35 dB]
7. Light Reflectance Coefficient (LR) [0.86] [0.88]
8. Recycled Content [32-39%]
9. Color White similar to RAL 9016
10. Flame Spread Classification (ASTM E 84) Class A, Flame Spread: 10, Smoke development: 20 Reaction to Fire: Euroclass A2-s1,d0 in accordance with EN-13501-1
11. Thermal Resistance: 0.31 m² °K/W - R 1.8 (19mm)
12. Humidity Resistance Maximum 95% RH / 40°C for ClimaPlus
13. Weight: 4.5 kg/m²
14. Mold Prevention application available upon request per ASTM D3273-1, Rate 10 per D3274
15. Relevant LEED Credit: EA Credit 1 | MR Credit 4 | MR Credit 5 | MR Credit 6 | IEQ Credit 3 | IEQ Credit 3.2 | IEQ Credit 4.6 | IEQ Credit 8.1 | IEQ Credit 9
16. Manufacturer, subject to compliance with USG Boral ME terms & Conditions
17. Product Name [Pedestal]

PERFORATED

STANDARD SPECIFICATION



PERFORATED SOUND ABSORPTION - 19 MM





Features & Benefits:

- Offered in Standard Pin Perforation for Ideal Mid-range sound absorption & sound Attenuation which provides balance to room acoustics
- Excellent for general commercial construction & HealthCare
- Maximum economy and design simplicity
- Could be available in Washable & Hygienic Paint upon request

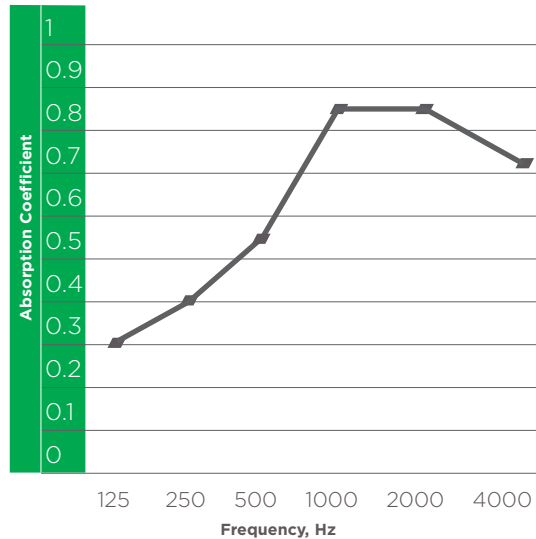
Applications:

- Schools
- Healthcare
- Corridors
- Lobby areas
- Offices
- Retail Stores



Item	Size	Edge Detail	NRC	CAC	LR	Recycled Content	VOC Emission	Cost
PS665 PS225	600*600*15 610*610*15	SQ	0.5	35	86%	32%	Low	\$
PSR665 PSR225	600*600*15 610*610*15	SLT	0.5	35	86%	32%	Low	\$
PSRF665 PSRF225	600*600*15 610*610*15	FLB	0.5	35	86%	32%	Low	\$
 PC665 PC225	600*600*15 610*610*15	SQ	0.5	35	86%	32%	Low	\$
 PCR665 PCR225	600*600*15 610*610*15	SLT	0.5	35	86%	32%	Low	\$
 PCRF665 PCRF225	600*600*15 610*610*15	FLB	0.5	35	86%	32%	Low	\$
 PC669 PC229	600*600*19 610*610*19	SQ	0.7	37	86%	32%	Low	\$\$
 PCR669 PCR229	600*600*19 610*610*19	SLT	0.7	37	86%	32%	Low	\$\$

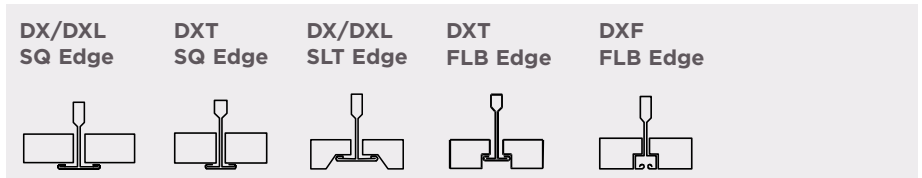

PART 2- PRODUCT

Product Specification Details | Acoustical Ceilings | 09 51 13

2.1 General

Provide Acoustical Ceiling Material manufactured to meet requirements of this specification in accordance with ASTM E 1264 and EN 13964.

2.2 Materials

Acoustical Ceiling Units:

1. Type III, Form 2, Pattern [C] [E]
2. Accessible acoustical ceiling system with pin perforated panels
3. Size 15, 19mm thick [600 x 600] [600 x 1200]
4. Edge Detail Trim (Square), Reveal (SLT) (FLB)
5. Noise Reduction Coefficient (NRC) [0.5]
6. Ceiling Attenuation Class (CAC) [35-37 dB]
7. Light Reflectance Coefficient (LR) 0.86
8. Recycled Content [32%]
9. Color White similar to RAL 9016
10. Surface Burning Characteristics per ASTM E 84 Class A, Flame Spread: 10, Smoke development: 20 Reaction to Fire: Euroclass A2-s1,d0 in accordance with EN-13501-1
11. Thermal Resistance: 0.23 m² °K/W - R 1.3 (15mm), 0.31 m² °K/W - R 1.8 (19mm)
12. Humidity Resistance Maximum 99% RH / 40°C for ClimaPlus
13. Weight: 3.55 kg/m² (Regular / ClimaPlus) 15mm, 4.5 kg/m² (Regular / ClimaPlus) 19mm
14. Mold Prevention application available upon request per ASTM D3273-1, Rate 10 per D3274
15. Relevant LEED Credit: EA Credit 1 | MR Credit 4 | MR Credit 5 | MR Credit 6 IEQ Credit 3 | IEQ Credit 3.2 | IEQ Credit 4.6 | IEQ Credit 8.1 | IEQ Credit 9
16. Manufacturer, subject to compliance with USG Boral ME terms & Conditions
17. Product Name [Perforated]

PLAIN

STANDARD SPECIFICATION



Features & Benefits:

- Panels are smoothed Plain for exceptional monolithic look
- Taiga or Plain panels were developed to meet with today's trend for cleaner finishes with high light reflectance at 86% to improve day lighting which result in energy cost savings and increased comfort level
- Low sound absorption, ideal where increased room reverberation is desired
- High humidity resistant in ClimaPlus, suitable for applications with intermittent heating and cooling.

Applications:

- Reception Areas showrooms and Lounges
- Shops
- Supermarkets/ Department
- Luxury Retail Stores
- General Offices
- Municipal buildings



Item	Size	Edge Detail	NRC	CAC	LR	Recycled Content	VOC Emission	Cost
BS665 BS225	600*600*15 610*610*15	SQ	0.15	33	86%	32%	Low	\$\$
BSR665 BSR225	600*600*15 610*610*15	SLT	0.15	33	86%	32%	Low	\$\$
BSRF665 BSRF225	600*600*15 610*610*15	FLB	0.15	33	86%	32%	Low	\$\$
BS669 BS229	600*600*19 610*610*19	SQ	0.15	36	86%	32%	Low	\$\$\$
BSR669 BSR229	600*600*19 610*610*19	SLT	0.15	36	86%	32%	Low	\$\$\$

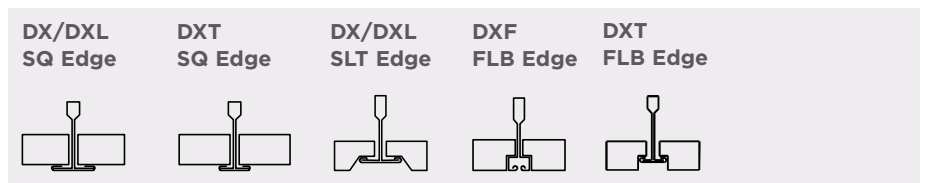

PART 2- PRODUCT

Product Specification Details | Acoustical Ceilings | 09 51 13

2.1 General

Provide Acoustical Ceiling Material manufactured to meet requirements of this specification in accordance with ASTM E 1264 and EN 13964.

2.2 Materials

Acoustical Ceiling Units:

1. Type III, Form 2, Pattern [G]
2. Factory Applied Vinyl Latex Paint Plain Finish
3. Size 15, 19mm thick [600 x 600] [600 x 1200]
4. Edge Detail Trim (Square), Reveal (SLT) (FLB)
5. Noise Reduction Coefficient (NRC) [0.15]
6. Ceiling Attenuation Class (CAC) [33-36 dB]
7. Light Reflectance Coefficient (LR) 0.86
8. Recycled Content [32%]
9. Color White similar to RAL 9016
10. Surface Burning Characteristics per ASTM E 84 Class A, Flame Spread: 10, Smoke development: 20 Reaction to Fire: Euroclass A2-S1,d0 in accordance with EN-13501-1
11. Thermal Resistance: 0.23 m² °K/W - R 1.3 (15mm), 0.31 m² °K/W - R 1.8 (19mm)
12. Humidity Resistance Maximum 95% RH / 40°C for ClimaPlus
13. Weight: 3.5 kg/m² 15mm, 4.5 kg/m² 19mm
14. Relevant LEED Credit: EA Credit 1 | MR Credit 4| MR Credit 5 | MR Credit 6 IEQ Credit 3 | IEQ Credit 3.2 | IEQ Credit 4.6 | IEQ Credit 8.1 | IEQ Credit 9
15. Manufacturer, subject to compliance with USG Boral ME terms & Conditions
16. Product Name [Plain]

RADAR™

STANDARD SPECIFICATION



Features & Benefits:





- 360° non directional pattern with a fresh, clean appearance offers fast, efficient installation
- Economical for all purpose ceiling pattern offered in many sizes
- Ideal for a balancing of sound absorption that provides balance to room acoustics and sound attenuation that is ideal for general commercial construction
- Fire resistant system options, for life safety and protection of property
- Available in 22mm for High NRC & High CAC panels
- Available also in Washable Paint, Plank Sizes

Applications:

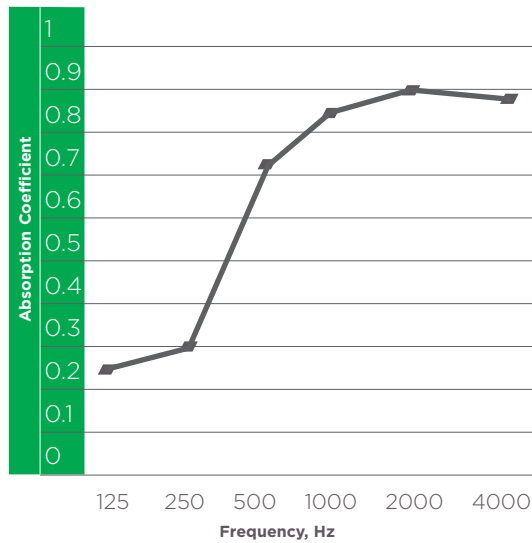
- Education
- Corridors
- Nurses office
- Cafeterias
- Libraries
- Open Office Plans
- Retail Stores

RADAR™ SOUND ABSORPTION - 19 MM



	Item	Size	Edge Detail	NRC	CAC	LR	Recycled Content	VOC Emission	Cost
	RDS665	600*600*15	SQ	0.5	36	85%	32%	Low	\$
	RDS225	610*610*15							
	RDSR665	600*600*15	SLT	0.5	36	85%	32%	Low	\$
	RDSR225	610*610*15							
	RDSRF665	600*600*15	FLB	0.5	36	85%	32%	Low	\$
	RDSRF225	610*610*15							
	RDC665	600*600*15	SQ	0.5	36	85%	32%	Low	\$
	RDC225	610*610*15							
	RDC625	600*1200*15	SQ	0.5	36	85%	32%	Low	\$
	RDC245	610*1220*15							
	RDCR665	600*600*15	SLT	0.5	36	85%	32%	Low	\$
	RDCR225	610*610*15							
	RDCRF665	600*600*15	FLB	0.5	36	85%	32%	Low	\$
	RDCRF225	610*610*15							
	RDX665	600*600*15	SQ	0.5	36	85%	46%	Low	\$\$
	RDX225	610*610*15							
	RDX625	600*1200*15	SQ	0.5	36	85%	46%	Low	\$\$
	RDX245	610*1220*15							
PLANKS	RDC325	300*1200*15	SQ	0.5	36	85%	32%	Low	\$ \$
	RDC145	310*1220*15							
	RDCR325	300*1200*15	SLT	0.5	36	85%	32%	Low	\$ \$
	RDCR145	310*1220*15							
	RDCRF325	300*1200*15	FLB	0.5	36	85%	32%	Low	\$ \$
	RDCRF145	310*1220*15							
	RDS669	600*600*19	SQ	0.6	37	85%	32%	Low	\$\$
	RDS229	610*610*19							
	RDSR669	600*600*19	SLT	0.6	37	85%	32%	Low	\$\$
	RDSR229	610*610*19							
	RDC669HNRC	600*600*19	SQ	0.7	40	85%	32%	Low	\$\$
	RDC229HNRC	610*610*19							
PLANKS	RDCR669HNRC	600*600*19	SLT	0.7	40	85%	32%	Low	\$\$
	RDCR229HNRC	610*610*19							
	RDC329	300*1200*19	SQ	0.6	37	85%	32%	Low	\$\$\$
	RDC149	310*1220*19							
	RDCR329	300*1200*19	SLT	0.6	37	85%	32%	Low	\$\$\$
	RDCR149	310*1220*19							
	RDCRF329	300*1200*19	FLB	0.6	37	85%	32%	Low	\$\$\$
	RDCRF149	310*1220*19							
	RDC669W	600*600*19	SQ	0.6	40	85%	32%	Low	\$\$\$
	RDC229W	610*610*19							
	RDCR669W	600*600*19	SLT	0.6	40	85%	32%	Low	\$\$\$
	RDCR229W	610*610*19							
	RDC6622	600*600*22	SQ	0.8	40	85%	32%	Low	\$\$\$
	RDC2222	610*610*22							
	RDCR6622	600*600*22	SLT	0.8	40	85%	32%	Low	\$\$\$
	RDCR2222	610*610*22							



RADAR™

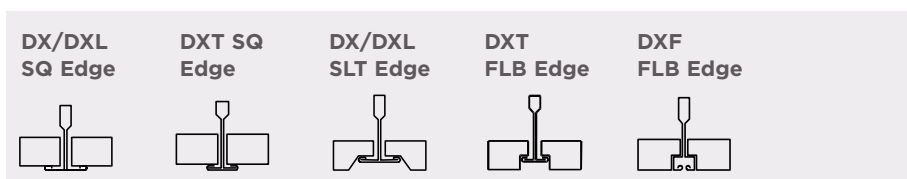

PART 2- PRODUCT

Product Specification Details | Acoustical Ceilings | 09 51 13

2.1 General

Provide Acoustical Ceiling Material manufactured to meet requirements of this specification in accordance with ASTM E 1264 and EN 13964.

2.2 Materials

Acoustical Ceiling Units:

1. Type III, Form 2, Pattern [C] [D] [E]
2. Fine non-directional fissured panel
3. Size 15, 19, 22mm thick [600 x 600] [600 x 1200] [300 x 1200]
4. Edge Detail Trim (Square), Reveal (SLT) (FLB)
5. Noise Reduction Coefficient (NRC) [0.5] [0.60] [0.70] [0.80]
6. Ceiling Attenuation Class (CAC) [35-40 dB]
7. Light Reflectance Coefficient (LR) 0.85
8. Recycled Content [32%] [46%]
9. Color White similar to RAL 9016
10. Surface Burning Characteristics per ASTM E 84 Class A, Flame Spread: 10, Smoke development: 20 Reaction to Fire: Euroclass A2-s1,d0 in accordance with EN-13501-1
11. Underwriters Laboratories Inc. Fire-Resistance (ASTM E 119) ANSI/UL 263 Time-Rated Assembly [2hrs] [J201]
12. Thermal Resistance: 0.23 m² °K/W - R 1.3 (15mm), 0.31 m² °K/W - R 1.8 (19mm), R - 1.9 (19mm High NRC)
13. Humidity Resistance Maximum 99% RH / 40°C for ClimaPlus
14. Weight: 3.55 kg/m² (Regular / ClimaPlus) 15mm, 5 kg/m² (Fire code) 15mm, 4.5 kg/m² (Regular / ClimaPlus) 19mm, 6.85 kg/m² (Fire code) 19mm
15. Mold Prevention application available upon request per ASTM D3273-1, Rate 10 per D3274
16. Relevant LEED Credit: EA Credit 1 | MR Credit 4 | MR Credit 5 | MR Credit 6 IEQ Credit 3 | IEQ Credit 3.2 | IEQ Credit 4.6 | IEQ Credit 8.1 | IEQ Credit 9
17. Manufacturer, subject to compliance with USG Boral ME terms & Conditions
18. Product Name [Radar™]

RADAR™ CERAMIC

STANDARD SPECIFICATION



Features & Benefits:

- 100% Ceramic Bonded Mineral Fiber
- Ensure Durability and considered the highest Environmental Resistant Panel
- Withstands high heat, ultra high humidity, corrosive chemical fumes & steam
- Ideally in live steam to withstand applications such as saunas & steam rooms
- Provides high Sound attenuation due to it's high density, for room to room privacy
- Humidity resistance up to 100% RH, 40°C without visible sag and in Fire code formulation
- Meets U.S. Coast Guard standards and can be used in high-humidity marine applications.
- 360° non directional pattern with a fresh, clean appearance offers fast, efficient installation
- Installed with DONN® ZXLA Aluminum corrosion-resistant grid system

Applications:

- Pools and shower areas
- Exterior soffits
- Parking Garages
- Saunas and steam rooms
- Food preparation areas
- Laboratories





Item	Size	Edge Detail	NRC	CAC	LR	Recycled Content	VOC Emission	Cost
RDXX665	600*600*15	SQ	0.4	40	83%	46%	N/A	\$\$\$\$
RDXX225	610*610*15							

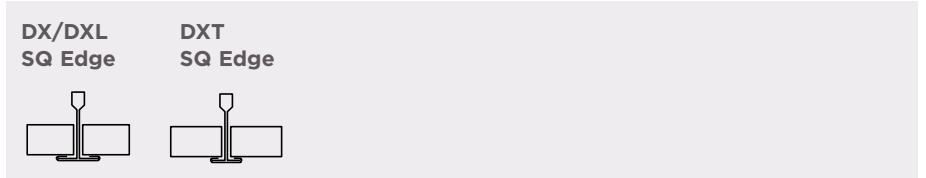

PART 2- PRODUCT

Product Specification Details | Acoustical Ceilings | 09 51 13

2.1 General

Provide Acoustical Ceiling Material manufactured to meet requirements of this specification in accordance with ASTM E 1264 and EN 13964.

2.2 Materials

Acoustical Ceiling Units:

1. Type XX, Form 2, Pattern [C] [D] [E]
2. Water Felted Ceramic Bonded Mineral fiber non-directional fissured panel
3. Size 15mm thick [600 x 600]
4. Edge Detail Trim (Square)
5. Noise Reduction Coefficient (NRC) [0.4]
6. Ceiling Attenuation Class (CAC) [40 dB]
7. Light Reflectance Coefficient (LR) 0.83
8. Recycled Content [46%]
9. Color White similar to RAL 9016
10. Surface Burning Characteristics per ASTM E 84 Class A, Flame Spread: 10, Smoke development: 20 Reaction to Fire: Euroclass A2-s1,d0 in accordance with EN-13501-1
11. Underwriters Laboratories Inc. Fire-Resistance (ASTM E 119) ANSI/UL 263 Time-Rated Assembly [2hrs] [G202]
12. Thermal Resistance: 0.23 m² °K/W - R 1.3 (15mm)
13. Humidity Resistance Maximum 100% RH / 40°C
14. Weight: 7.8 kg/m²
15. Inert to Mold Growth
16. Relevant LEED Credit: EA Credit 1 | MR Credit 4| MR Credit 5 | MR Credit 6 IEQ Credit 3 | IEQ Credit 3.2 | IEQ Credit 4.6 | IEQ Credit 8.1 |IEQ Credit 9
17. Manufacturer, subject to compliance with USG Boral ME terms & Conditions
18. Product Name [Radar Ceramic™]

SANDRIFT™

STANDARD SPECIFICATION

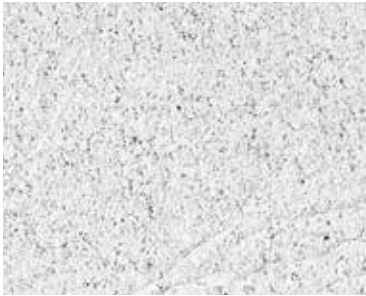

Features & Benefits:



- Casted Panels with a durable surface that resist scrapes commonly caused by accessing ceiling plenum
- Soft, rolling texture of drifting sand
- Embossed texture that replicates the natural beauty of drifting snow, ideal for use with up lighting or strong side lighting to accentuate the textured design
- Combination of High sound absorption and High sound attenuation when laminated with Paper back surface for effective reduction of unwanted noise and excellent privacy
- HRC (High Recycled Content) for optimized recycled content formulations to help maximize LEED recycled content contribution
- Available strictly in ClimaPlus for 95% RH resistance and Reveal Edge panels and in Firecode formulation
- Aluminum foil or paper backing acts as a sound barrier and resists air filtration for cleaner panels
- Classified as zero-emitting per standards established by the Collaborative for High-Performance Schools (CHPS), following California Specification 01350 testing methods

Applications:

- Conference and Lobby areas
- Department Stores
- Entertainment and Gaming
- Executive Offices
- Cafeteria/Restaurant

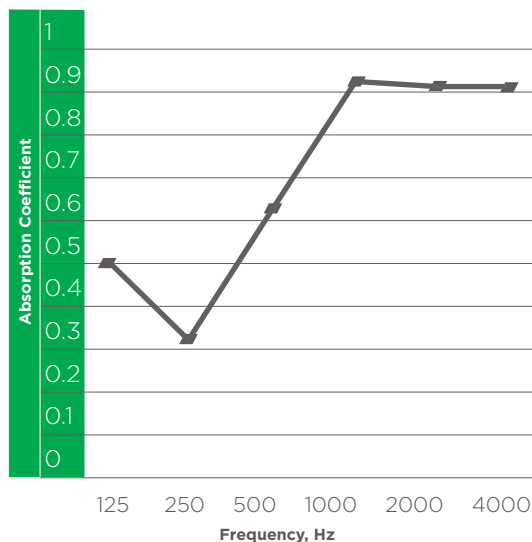
SANDRIFT™ SOUND ABSORPTION



	Item	Size	Edge Detail	NRC	CAC	LR	Recycled Content	VOC Emission	Cost
	808 Paper-Back	610*610*19	SL	0.7	38	83%	71%	Zero	\$\$\$
	809 Paper-Back	610*610*19	FL	0.7	38	83%	71%	Zero	\$\$\$
	815 Foil-Back	610*610*19	SL	0.55	35	83%	70%	Zero	\$\$\$

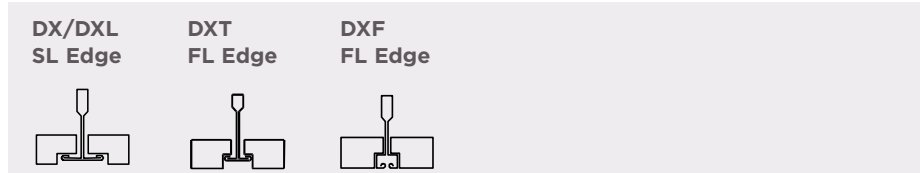

PART 2- PRODUCT

Product Specification Details | Acoustical Ceilings | 09 51 13

2.1 General

Provide Acoustical Ceiling Material manufactured to meet requirements of this specification in accordance with ASTM E 1264.

2.2 Materials

Acoustical Ceiling Units:

1. Type III, Form 4, Pattern [Z]
2. Fine textured panels
3. Size 19 mm thick [600 x 600]
4. Edge Detail Reveal (SL) (FL)
5. Noise Reduction Coefficient (NRC) [0.55] [0.7]
6. Ceiling Attenuation Class (CAC) [35-38 dB]
7. Light Reflectance Coefficient (LR) 0.83
8. Recycled Content [71%]
9. Color White similar to RAL 9016
10. Surface Burning Characteristics per ASTM E 84 Class A, Flame Spread:25, Smoke development:50
11. Underwriters Laboratories Inc. Fire-Resistance (ASTM E 119) ANSI/UL 263 Time-Rated Assembly [2hrs] [G228]
12. Thermal Resistance: R 1.7 (Class A), R 1.3 (Fire Code)
13. Humidity Resistance Maximum 95% RH / 40°C ClimaPlus
14. Weight: 8 kg/m² (Class A), 8.35 kg/m² (Fire code)
15. Mold Prevention application per ASTM D3273-1, Rate 10 per D3274
16. VOC Class: Zero emission per CHPS Collaborative for High-Performance Schools
17. Relevant LEED Credit: EA Credit 1 | MR Credit 4 | MR Credit 5 | MR Credit 6 | IEQ Credit 3 | IEQ Credit 3.2 | IEQ Credit 4.6 | IEQ Credit 8.1 | IEQ Credit 9
18. Manufacturer, subject to compliance with USG Boral ME terms & Conditions
19. Product Name [Sandrift™]

SKYROCK CLASSIC

STANDARD SPECIFICATION



Features & Benefits:

- Stone Wool substrate with Elegant monolithic White Surface
- Exceptional Sound Absorption with NRC values up to 1
- Low Gloss, High Light Reflectance (LR-0.85) reduces light fixtures & Energy use
- Moisture resistance to withstand conditions up to 25°C (77°F) / 95% relative humidity without visible sag when used with DONN Brand suspension system
- Eco-friendly mineral wool product made from natural stone

Applications:

- Open-plan Offices
- Offices with indirect lighting
- Restaurant Environments
- Media Room
- Conference facilities
- Reception Areas
- Libraries

SKYROCK CLASSIC SOUND ABSORPTION - 18 MM

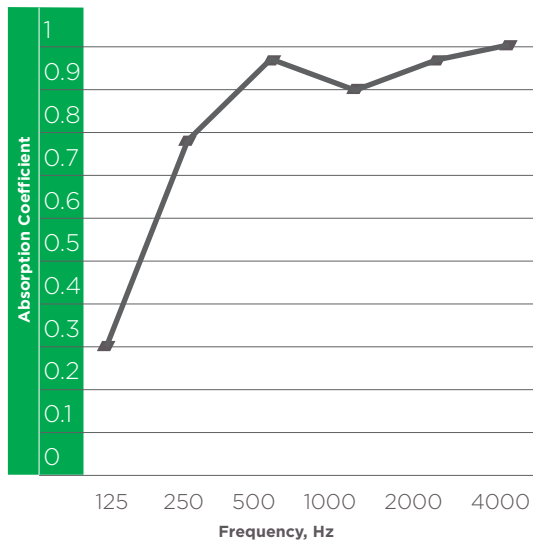

	Item	Size	Edge Detail	NRC	CAC	LR	Recycled Content	VOC Emission	Cost
☀️	SKC665	600*600*15	SQ	0.85		85%	15%	M1	\$\$\$
	SKC225	610*610*15							
☔️	SKCR665	600*600*15	SLT	0.85		85%	15%	M1	\$\$\$
	SKCR225	610*610*15							
☔️	SKCRF665	600*600*15	FL	0.85		85%	15%	M1	\$\$\$
	SKCRF225	610*610*15							
☀️	SKC668	600*600*18	SQ	0.9		85%	15%	M1	\$\$\$\$
	SKC228	610*610*18							
☔️	SKC628	600*1200*18	SQ	0.9		85%	15%	M1	\$\$\$\$
	SKC248	610*1220*18							
☀️	SKCR668	600*600*18	SLT	0.9		85%	15%	M1	\$\$\$\$
	SKCR228	610*610*18							
☔️	SKCRF668	600*600*18	FL	0.9		85%	15%	M1	\$\$\$\$
	SKCRF228	610*610*18							
☔️	SKC6625	600*600*25	SQ	0.95		85%	15%	M1	\$\$\$\$
	SKC2225	610*610*25							
☔️	SKC6225	600*1200*25	SQ	0.95		85%	15%	M1	\$\$\$\$
	SKC2425	610*1220*25							
☔️	SKC6240	600*1200*40	SQ	1	28	85%	15%	M1	\$\$\$\$
	SKC2440	610*1220*40							

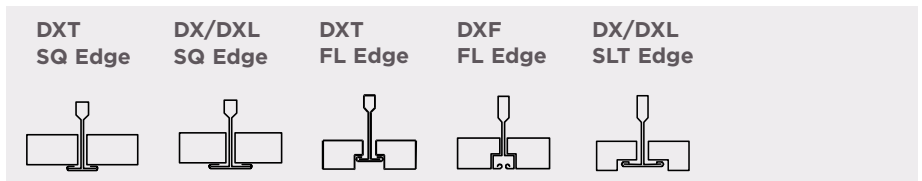

PART 2- PRODUCT

Product Specification Details | Acoustical Ceilings | 09 51 13

2.1 General

Provide Acoustical Ceiling Material manufactured to meet requirements of this specification in accordance with EN 13964:2014.

2.2 Materials

Acoustical Ceiling Units:

1. Type IV, Pattern [G]
2. Stone Wool Substrate finished with Pre Painted Fiber Glass scrim layer & Backside thin Glass fiber tissue
3. Size 15,18,25,40 mm thick [600 x 600] [600 x 1200]
4. Edge Detail Trim (Square) (SLT) (FL)
5. Noise Reduction Coefficient (NRC) [0.85][0.9][0.95][1]
6. Ceiling Attenuation Class (CAC) [28 dB]
7. Light Reflectance Coefficient (LR) 0.85
8. Recycled Content [15%]
9. Color White similar to RAL 9016 and Flat Black Color similar to RAL 9005
10. Surface Burning Characteristics per ASTM E84 Class A, Flame Spread<25, Smoke developed<50 Reaction to Fire: Euroclass A2-s1,d0 in accordance with EN-13501-1
11. Thermal Resistance: 0.44 m² °K/W (15mm), 1.17 m² °K/W (40mm)
12. Humidity Resistance 95% RH / 30°C
13. Weight: 1.1 kg/m² for 15mm, 1.4 kg/m² for 18mm, 1.8 Kg/m² for 25mm, 2.8 kg/m² for 40mm
14. Manufacturer, subject to compliance with USG Boral ME terms & Conditions
15. Product Name [Skyrock Classic]

SKYROCK NORDIC

STANDARD SPECIFICATION



Features & Benefits:

- Stone Wool substrate with White surface layer for basic requirements and applications
- Exceptional Sound Absorption with NRC of 0.95
- Low Gloss, White surface layer that has a low gloss factor and good light reflection (LR-0.83)
- Moisture resistance to withstand conditions up to 25°C (77°F) / 95% relative humidity without visible sag when used with DONN Brand suspension system
- Non Combustible panels (Euro Class A1) and exceptional Humidity Resistance up to 95% RH

Applications:

- Public Space
- Offices
- Schools
- Nurseries
- Commercial Premises

SKYROCK NORDIC SOUND ABSORPTION - 15 MM

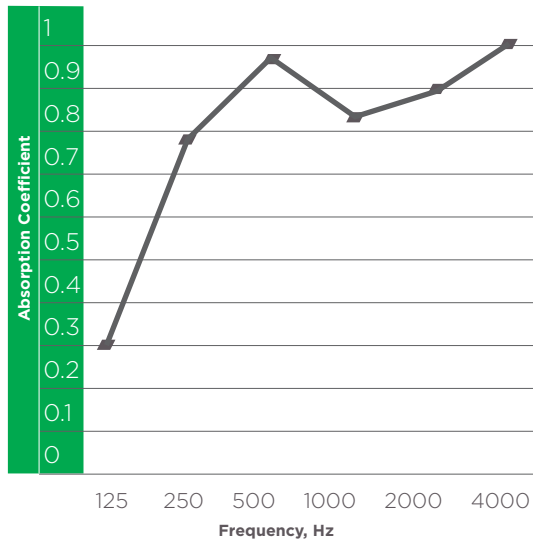

	Item	Size	Edge Detail	NRC	CAC	LR	Recycled Content	VOC Emission	Cost
☀️	SKX662	600*600*12	SQ	0.8		77%	15%	M1	\$\$
	SKX222	610*610*12							
☀️	SKNR665	600*600*15	SLT	0.85		83%	15%	M1	\$\$\$
	SKN225	610*610*15							
☀️	SKNR665	600*600*15	SLT	0.85		83%	15%	M1	\$\$\$
	SKNR225	610*610*15							
☀️	SKNRF665	600*600*15	FL	0.85		83%	15%	M1	\$\$\$
	SKNRF225	610*610*15							
☀️	SKN668	600*600*18	SQ	0.9		83%	15%	M1	\$\$\$\$
	SKN228	610*610*18							
☀️	SKN628	600*1200*18	SQ	0.9		83%	15%	M1	\$\$\$\$
	SKN248	610*1220*18							
☀️	SKNR668	600*600*18	SLT	0.9		83%	15%	M1	\$\$\$\$
	SKNR228	610*610*18							
☀️	SKNRF668	600*600*18	FL	0.9		83%	15%	M1	\$\$\$\$
	SKNRF228	610*610*18							
☀️	SKN6625	600*600*25	SQ	0.95		83%	15%	M1	\$\$\$\$
	SKN2225	610*610*25							
☀️	SKN6225	600*1200*25	SQ	0.95		83%	15%	M1	\$\$\$\$
	SKN2425	610*1220*25							

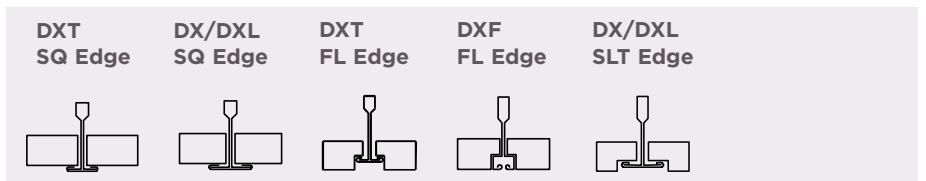

PART 2- PRODUCT

Product Specification Details | Acoustical Ceilings | 09 51 13

2.1 General

Provide Acoustical Ceiling Material manufactured to meet requirements of this specification in accordance with EN 13964:2014.

2.2 Materials

Acoustical Ceiling Units:

1. Type IV, Pattern [G]
2. Stone Wool Substrate finished with Pre Painted Fiber Glass scrim layer & Backside thin Glass fiber tissue
3. Size 12,15,18,25mm thick [600 x 600] [600 x 1200]
4. Edge Detail Trim (Square) (SLT) (FL)
5. Noise Reduction Coefficient (NRC) [0.85][0.9][0.95]
6. Light Reflectance Coefficient (LR) 0.83
7. Recycled Content [15%]
8. Color White similar to RAL 9016
9. Reaction to Fire: Euroclass A1 in accordance with EN-13501-1
10. Thermal Resistance: 0.44 m² °K/W (15mm)
11. Humidity Resistance 95% RH / 25°C
12. Weight: 0.85 kg/m² for 12mm, 1.1 kg/m² for 15mm, 1.4 kg/m² for 18mm, 1.8 Kg/m² for 25mm
13. Manufacturer, subject to compliance with USG Boral ME terms & Conditions
14. Product Name [Skyrock Nordic]

SONATA

STANDARD SPECIFICATION



Features & Benefits:

- Fine, monolithic texture Industry's highest light reflectance LR 0.89 reduces light fixtures and energy use is part of Indirect lighting
- High Impact and scratch resistance, durable and cleanable surface
- Available in High NRC formulation and in optimized recycled content formulations to help maximize LEED recycled content contribution
- ClimaPlus type with antimicrobial treatment is suitable for healthcare application
- Available for water repellency application on both Top and back surfaces
- Available in Plank size, FLB edges compatible with Logix Integrated Ceiling System

Applications:

- Healthcare
- Executive Offices and Conference rooms
- Reception areas and Lobbies
- Classrooms
- Corridors
- Dining rooms, kitchens and food-prep areas

SONATA SOUND ABSORPTION - 19 MM

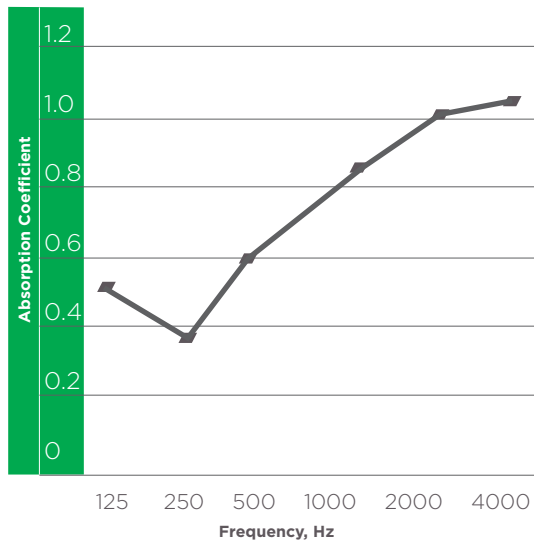

	Item	Size	Edge Detail	NRC	CAC	LR	Recycled Content	VOC Emission	Cost
☂	SC669	600*600*19	SQ	0.75	37	89%	83%	Low	\$\$\$\$
	SC229	610*610*19							
☂	SCR669	600*600*19	SLT	0.75	37	89%	83%	Low	\$\$\$\$
	SCR229	610*610*19							
☂	SCRF669	600*600*19	FLB	0.75	37	89%	83%	Low	\$\$\$\$
	SCRF229	610*610*19							
☂	SC629	600*1200*19	SQ	0.75	37	89%	83%	Low	\$\$\$\$
	SC249	610*1220*19							
☂	SCR629	600*1200*19	SLT	0.75	37	89%	83%	Low	\$\$\$\$
	SCR249	610*1220*19							
☂	SCRF629	600*1200*19	FLB	0.75	37	89%	83%	Low	\$\$\$\$
	SCRF249	610*1220*19							

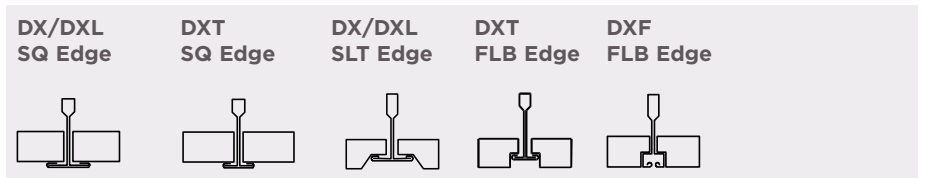

PART 2- PRODUCT

Product Specification Details | Acoustical Ceilings | 09 51 13

2.1 General

Provide Acoustical Ceiling Material manufactured to meet requirements of this specification in accordance with ASTM E 1264 and EN 13964.

2.2 Materials

Acoustical Ceiling Units:

1. Type IV, Form 2, Pattern [E] [G]
2. Mineral Fiber Substrate manufactured in wet Felted Technology and finished with Painted Fiber Glass scrim
3. Size 19,22 mm thick [600 x 600] [600 x 1200] [300 x 1200] [300 x 1500]
4. Edge Detail Trim (Square), Reveal (SLT) (FLB)
5. Noise Reduction Coefficient (NRC) [0.75]
6. Ceiling Attenuation Class (CAC) [37-40 dB]
7. Light Reflectance Coefficient (LR) 0.89
8. Recycled Content [up to 83%]
9. Color White similar to RAL 9016
10. Surface Burning Characteristics per ASTM E84 Class A, Flame Spread:20, Smoke development:70 Reaction to Fire: Euroclass A2-s1,d0 in accordance with EN-13501-1
11. Fire Resistance ASTM E 119 ANSI/UL 263 time-rated assembly [2hrs] [J201]
12. Thermal Resistance: 0.31 m² °K/W - R 1.8 (19mm)
13. Humidity Resistance Maximum 99% RH / 40°C
14. Weight: 5 kg/m²
15. Mold Prevention application per ASTM D3273-1, Rate 10 per D3274
16. Washability / Scrubbability: Exceeds 1000 Wash/Scrub Cycles without surface break or the extent of abrasion per ASTM D4828 & D2486
17. Available in Water Repellency on Top & Back surface for HealthCare application up to 5 Hours under [Sonata HealthCare]
18. Relevant LEED Credit: EA Credit 1 | MR Credit 4 | MR Credit 5 | MR Credit 6 | IEQ Credit 3 | IEQ Credit 3.2 | IEQ Credit 4.6 | IEQ Credit 8.1 | IEQ Credit 9
19. Manufacturer, subject to compliance with USG Boral ME terms & Conditions
20. Product Name [Sonata]

SONATA HEALTHCARE

STANDARD SPECIFICATION



Features & Benefits:

- Water repellent membrane on both top and back surfaces
- Fine, monolithic texture Industry's highest light reflectance LR 0.89 reduces light fixtures and energy use is part of Indirect lighting
- High Impact and scratch resistance, durable and cleanable surface
- Available in High NRC formulation and in optimized recycled content formulations to help maximize LEED recycled content contribution
- Available in Plank size, FLB edges compatible with Logix Integrated Ceiling System
- Washable and scrubbable finish
- CLIMAPLUS 30 year lifetime system warranty against visible sag, mold and mildew. Also with antimicrobial treatment

Applications:

- Healthcare
- Executive Offices and Conference rooms
- Reception areas and Lobbies
- Classrooms
- Corridors
- Dining rooms, kitchens and food-prep areas

SONATA HEALTHCARE SOUND ABSORPTION - 19 MM

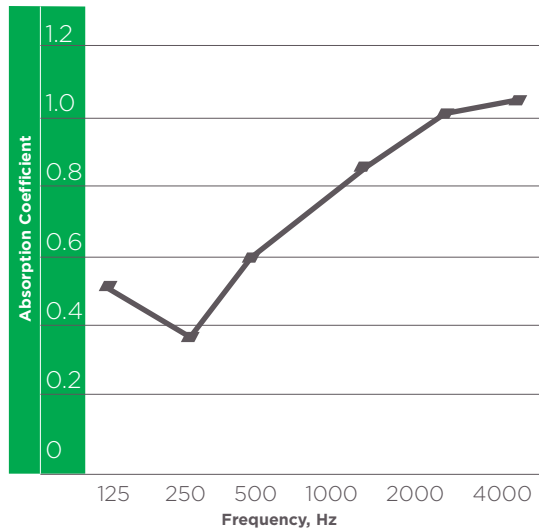

	Item	Size	Edge Detail	NRC	CAC	LR	Recycled Content	VOC Emission	Cost
☂	SC669HC	600*600*19	SQ	0.75	37	89%	83%	Low	\$\$\$\$
	SC229HC	610*610*19							
☂	SCR669HC	600*600*19	SLT	0.75	37	89%	83%	Low	\$\$\$\$
	SCR229HC	610*610*19							
☂	SCRF669HC	600*600*19	FLB	0.75	37	89%	83%	Low	\$\$\$\$
	SCRF229HC	610*610*19							
☂	SC629HC	600*1200*19	SQ	0.75	37	89%	83%	Low	\$\$\$\$
	SC249HC	610*1220*19							
☂	SCR629HC	600*1200*19	SLT	0.75	37	89%	83%	Low	\$\$\$\$
	SCR249HC	610*1220*19							
☂	SCRF629HC	600*1200*19	FLB	0.75	37	89%	83%	Low	\$\$\$\$
	SCRF249HC	610*1220*19							

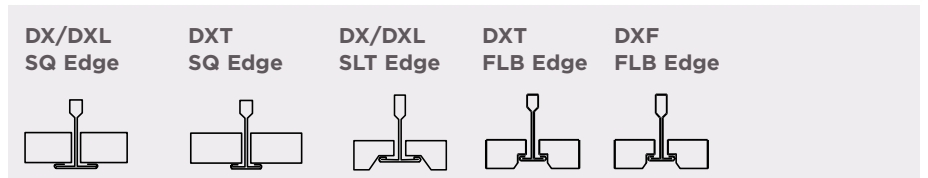

PART 2- PRODUCT

Product Specification Details | Acoustical Ceilings | 09 51 13

2.1 General

Provide Acoustical Ceiling Material manufactured to meet requirements of this specification in accordance with ASTM E 1264 and EN 13964.

2.2 Materials

Acoustical Ceiling Units:

1. Type IV, Form 2, Pattern [E] [G]
2. Mineral Fiber Substrate manufactured in wet Felted Technology and finished with Painted Fiber Glass scrim
3. Size 19,22 mm thick [600 x 600] [600 x 1200] [300 x 1200] [300 x 1500]
4. Edge Detail Trim (Square), Reveal (SLT) (FLB)
5. Noise Reduction Coefficient (NRC) [0.75]
6. Ceiling Attenuation Class (CAC) [37-40 dB]
7. Light Reflectance Coefficient (LR) 0.89
8. Recycled Content [up to 83%]
9. Color White similar to RAL 9016
10. Surface Burning Characteristics per ASTM E84 Class A, Flame Spread:20, Smoke development:70 Reaction to Fire: Euroclass A2-s1,d0 in accordance with EN-13501-1
11. Fire Resistance ASTM E119 ANSI/UL 263 Time-Rated Assembly (2Hrs) (J201)
12. Thermal Resistance: 0.31 m² °K/W - R 1.8 (19mm)
13. Humidity Resistance Maximum 99% RH / 40°C
14. Weight: 5 kg/m²
15. Mold Prevention application per ASTM D3273-1, Rate 10 per D3274
16. Washability / Scrubbability: Exceeds 1000 Wash/Scrub Cycles without surface break or the extent of abrasion per ASTM D4828 & D2486
17. Water repellent membrane on Top & Back surface up to 5 Hours
18. Relevant LEED Credit: EA Credit 1 | MR Credit 4 | MR Credit 5 | MR Credit 6 | IEQ Credit 3 | IEQ Credit 3.2 | IEQ Credit 4.6 | IEQ Credit 8.1 | IEQ Credit 9
19. Manufacturer, subject to compliance with USG Boral ME terms & Conditions
20. Product Name [Sonata HealthCare]

SPARTA

STANDARD SPECIFICATION

Plain White



Star Plus



Features & Benefits:

- Laminated Washable Vinyl facing for easy maintenance
- Available only in Plain facings with smooth appearance for Plain White pattern and light texture for Star Plus pattern
- Ultra high humidity resistant and sag resistance ensures durability in standard or extreme environmental conditions. May be installed early in the building program
- It comes with Aluminum Foil backing which acts as a vapor barrier and resists breathing so panel stays cleaner longer
- Scrub resistant. Dirt marks are easy to remove
- Scuff and scratch resistant, for longer life
- Very suitable for HealthCare applications
- Economical and easy to trim and install

Applications:

- Healthcare / Laboratories
- Leisure/ IT Room
- Toilet/Wet Areas
- Department Stores
- Retail Showrooms



Item	Size	Edge Detail	NRC	CAC	LR	Recycled Content	VOC Emission	Cost
LSP665 LSP225	600*600*15 610*610*15	SQ	0.15	35	84%	32%	Low	\$
LPW665 LPW225	600*600*15 610*610*15	SQ	0.15	35	84%	32%	Low	\$
LSP669 LSP229	600*600*19 610*610*19	SQ	0.15	36	84%	32%	Low	\$\$
LPW669 LPW229	600*600*19 610*610*19	SQ	0.15	36	84%	32%	Low	\$\$

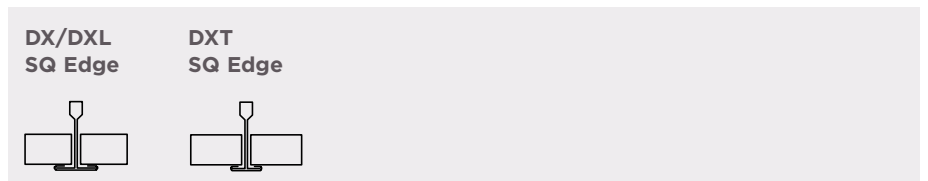

PART 2- PRODUCT

Product Specification Details | Acoustical Ceilings | 09 51 13

2.1 General

Provide Acoustical Ceiling Material manufactured to meet requirements of this specification in accordance with ASTM E 1264.

2.2 Materials

Acoustical Ceiling Units:

1. Type X, Pattern [G]
2. Smooth and textured laminated panels
3. Size 15, 19mm thick [600 x 600]
4. Edge Detail Trim (Square)
5. Noise Reduction Coefficient (NRC) [0.15]
6. Ceiling Attenuation Class (CAC) [35-36 dB]
7. Light Reflectance Coefficient (LR) 0.84
8. Recycled Content [32%]
9. Color White similar to RAL 9016
10. Thermal Resistance: 0.23 m² °K/W - R 1.3 (15mm), 0.31 m² °K/W - R 1.8 (19mm)
11. Humidity Resistance Maximum 99% RH / 40°C
12. Weight: 3.5 kg/m² 15mm, 4.5 kg/m² 19mm
13. Mold Prevention: Inherent to Mold/Mildew growth
14. Relevant LEED Credit: EA Credit 1 | MR Credit 4| MR Credit 5 | MR Credit 6
IEQ Credit 3 | IEQ Credit 3.2 | IEQ Credit 4.6 | IEQ Credit 8.1 | IEQ Credit 9
15. Manufacturer, subject to compliance with USG Boral ME terms & Conditions
16. Product Name [Sparta]

TAIGA HYGIENE

STANDARD SPECIFICATION

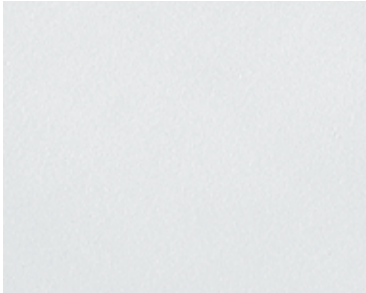

Features & Benefits:

- Panels are offered in smoothed Plain and are suitable for healthcare application.
- Taiga Hygiene has been developed to meet the most stringent demand on hygiene and clean ability
- All Taiga Hygiene items have a special fungicide treatment in the core and on the finished painted surface to enhance the resistance to growth of micro-organisms and ensure regular clean ability. It contains a broad-spectrum antimicrobial additive on the face and the back of the panel that provides resistance against the growth of mold and mildew.
- High light reflectance performance 86%
- High humidity resistant in ClimaPlus, suitable for applications with intermittent heating and Cooling

Applications:

- Healthcare
- Consulting/Patient/treatment Rooms
- Clinics / Laboratories
- Schools
- General Offices



Item	Size	Edge Detail	NRC	CAC	LR	Recycled Content	VOC Emission	Cost
NA4107M-ME	600*600*15	SQ	0.15	33	86%	32%	Low	\$\$
NA4107M-IM	610*610*15							
NB4107M-ME	600*600*15	SLT	0.15	33	86%	32%	Low	\$\$
NB4107M-IM	610*610*15							
NC4107M-ME	600*600*19	FLB	0.15	36	86%	32%	Low	\$\$
NC4107M-IM	610*610*19							
NA4997M-ME	600*600*19	SQ	0.15	36	86%	32%	Low	\$\$\$
NA4997M-IM	610*610*19							
NB4997M-ME	600*600*19	SLT	0.15	36	86%	32%	Low	\$\$\$
NB4997M-IM	610*610*19							

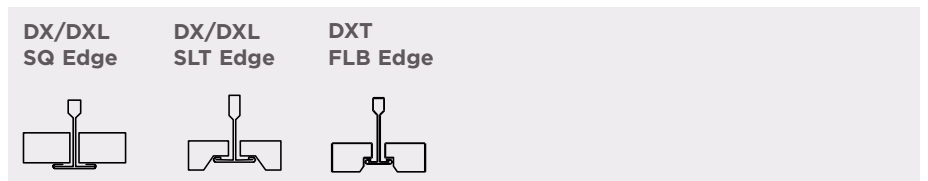

PART 2- PRODUCT

Product Specification Details | Acoustical Ceilings | 09 51 13

2.1 General

Provide Acoustical Ceiling Material manufactured to meet requirements of this specification in accordance with ASTM E 1264 and EN 13964.

2.2 Materials

Acoustical Ceiling Units:

1. Type III, Form 2, Pattern [G]
2. Plain finish panels
3. Size 15, 19mm thick [600 x 600]
4. Edge Detail Trim (Square), Reveal (SLT)
5. Noise Reduction Coefficient (NRC) [0.15]
6. Ceiling Attenuation Class (CAC) [33-36 dB]
7. Light Reflectance Coefficient (LR) 0.86
8. Recycled Content [32%]
9. Color White similar to RAL 9016
10. Surface Burning Characteristics per ASTM E 84 Class A, Flame Spread: 10, Smoke development: 20 Reaction to Fire: Euroclass A2-s1,d0 in accordance with EN-13501-1
11. Thermal Resistance: 0.23 m² °K/W - R 1.3 (15mm), 0.31 m² °K/W - R 1.8 (19mm)
12. Humidity Resistance Maximum 99% RH / 40°C for ClimaPlus
13. Weight: 3.5 kg/m² 15mm, 4.5 kg/m² 19mm
14. Mold Prevention application per ASTM D3273-1, Rate 10 per D3274
15. Washability / Scrubbability: Exceeds 1000 Wash/Scrub Cycles without surface break or the extent of abrasion per ASTM D4828 & D2486
16. Relevant LEED Credit: EA Credit 1 | MR Credit 4 | MR Credit 5 | MR Credit 6 | IEQ Credit 3 | IEQ Credit 3.2 | IEQ Credit 4.6 | IEQ Credit 8.1
17. Manufacturer, subject to compliance with USG Boral ME terms & Conditions
18. Product Name [Taiga Hygiene]

WOOD TONE

STANDARD SPECIFICATION

Beech



Cherry



Maple



Walnut



Alder



Oak



Mahogany



Polaris



Features & Benefits:

- Mineral Fiber Panels finished with Decorative Laminates of wood for Rustic and Majestic look for Residential & Business centers
- Ideal for Traditional, Casual, Contemporary appearance in Residential application, Kitchens, Dining room, Hotel Breakfast area, Restaurant
- Laminated with Thin layer of CPL (Continuous Press Laminates) of wood
- Panel Finished with textures: Oak, Alder, Cherry, Maple, Beech, walnut and available in 9 different wood tone colors
- Ultra high humidity resistant and sag resistance ensures durability in standard or extreme environmental conditions.
- It can come with Aluminum Foil backing which acts as a vapor barrier and resists breathing so panel stays cleaner longer
- Easy washable dirt marks are easy to remove. It may be cleaned with warm water and mild soaps
- Extra Durable, Scratch and impact resistance for long life Ceiling

Applications:

- Leisure
- Theaters
- Restaurants/ cafes
- Exhibitions
- Conference Room
- Basement
- Residential: Dining Room, Kitchen
- Hotels



Item	Size	Edge Detail	NRC	CAC	Recycled Content	VOC Emission	Cost
LWT665	600*600*15	SQ	0.15	35	32%	Low	\$\$\$\$
LWT225	610*610*15						
LWT669	600*600*19	SQ	0.15	36	32%	Low	\$\$\$\$
LWT229	610*610*19						

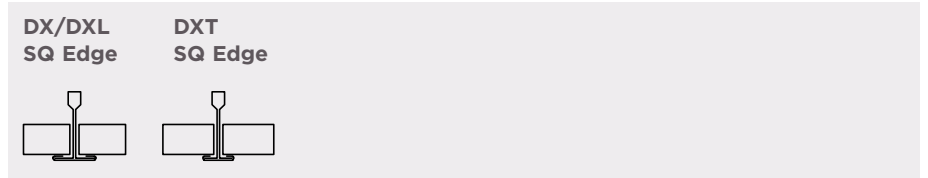

PART 2- PRODUCT

Product Specification Details | Acoustical Ceilings | 09 51 13

2.1 General

Provide Acoustical Ceiling Material manufactured to meet requirements of this specification in accordance with ASTM E 1264.

2.2 Materials

Acoustical Ceiling Units:

1. Type X, Pattern [G]
2. Smooth and textured laminated panels
3. Size 15, 19mm thick [600 x 600]
4. Edge Detail Trim (Square)
5. Noise Reduction Coefficient (NRC) [0.15]
6. Ceiling Attenuation Class (CAC) [35-36 dB]
7. Recycled Content [32%]
8. Available in multiple colors
9. Surface Burning Characteristics per ASTM E84, Class B
- 10 Thermal Resistance: 0.23 m² °K/W - R 1.3 (15mm), 0.31 m² °K/W - R 1.8 (19mm)
11. Humidity Resistance Maximum 95% RH / 40°C
12. Weight: 4 kg/m² 15mm, 5 kg/m² 19mm
13. Mold Prevention: Inherent to Mold/Mildew growth
14. Relevant LEED Credit: MR Credit 4 | MR Credit 5 | MR Credit 6 | IEQ Credit 3 | IEQ Credit 3.2 | IEQ Credit 4.6
15. Manufacturer, subject to compliance with USG Boral ME terms & Conditions
16. Product Name [Wood Tone]



METAL CEILING INSPIRED BY YOU



METAL CEILING SYSTEMS

USG BORAL ME BUILDS A WORLD OF POSSIBILITIES

USG Boral ME offers a wide range of high quality aluminum alloy and metal ceiling system that increase the aesthetic and functional value of your interiors within a modest ceiling budget.

USG Boral ME's superior quality metal ceiling products are available in standard suspended ceiling systems such as exposed grid / concealed suspension system; custom-made metal ceiling is also available on request to meet the different requirements of architect specification design.

UNLIMITED DESIGN, RELIABLE PERFORMANCE

The USG Boral ME portfolio combines aesthetic, durability and performance:

- Wide range of standard patterns, other patterns are available upon request
- Durable and washable polyester powder finish
- Easy access for service maintenance
- Robust and easy to clean
- High sound absorption and sound attenuation
- Extensive range of perimeter options
- Environmentally friendly and recyclable

APPLICATION

USG Boral ME also offers unique systems providing the specifier unlimited design possibilities for applications ranging from banks to corporate offices, airports till shopping malls. For Metal Ceiling exterior application under a soffit, contact USG Boral ME technical team.

MATERIALS AND MANUFACTURER

Metal ceiling panels are all antibacterial tiles which are press formed from aluminum alloy series 3000 or mild steel and factory finished with an electrostatically applied polyester powder coat (70-90 microns). The paint's grade varies widely from commercial to super durable to comply with most of the projects requirements. Panel thickness range from 0.6 to 1.4mm, other thickness is available upon request. Suspension components are made from galvanized steel or and pre-painted steel/ aluminum.



COLOR

The standard color is RAL 9016 white 20% gloss, RAL9006 and RAL9010. Other colors are available upon request.

HIGH QUALITY STANDARD

Our design and manufacture are strictly in conformance with the plant's Good Manufacturing Practice.

LIFE CYCLE BENEFITS

USG Boral ME metal ceilings are very durable, which can be easily cleaned and have a long life span.

RECYCLABLE PRODUCT

USG Boral ME's ceiling panels are available with High Recycled Content (HRC). HRC Ceiling Panels and Trim are classified as containing above 50% of total recycled content. Total recycled content is based on product composition of post-consumer and pre-consumer (post-industrial) recycled content per FTC guidelines. The use of recyclable materials has obvious environmental benefits when the products are ready for disposal.

SEISMIC PERFORMANCE

Available upon request in full compliance with ASTM E580.

FIRE PERFORMANCE

Fire rated designed class A as per ASTM E84 is available upon request.

ACOUSTICAL PERFORMANCE

A balanced acoustical environment often plays an important part in improving productivity, comfort and people's sense of well being. Through appropriate selection of perforation pattern and acoustic infill, it is possible to improve speech intelligibility, reduce unwanted noise and increase privacy within space or between adjacent offices.

SOUND ABSORPTION

"Sound absorption" describes the reduction of noise within a room. Perforated ceiling tiles with an acoustic fleece overlay or mineral wool pad absorb sound energy and serve to control acoustic reverberation time. Different combinations of perforated open areas and acoustic pad density / thickness provide different levels of sound absorption. NRC defines the average sound absorption of the ceiling system.

SOUND ATTENUATION

Sound attenuation refers to noise passing into room from outside, such as room to room noise from the services above ceiling. The test data in dB for each ceiling panel gives guidance on sound insulation but should be seen in the context on the overall room construction. USG Boral ME ceiling panels can be manufactured with a range of mineral wool acoustic infill

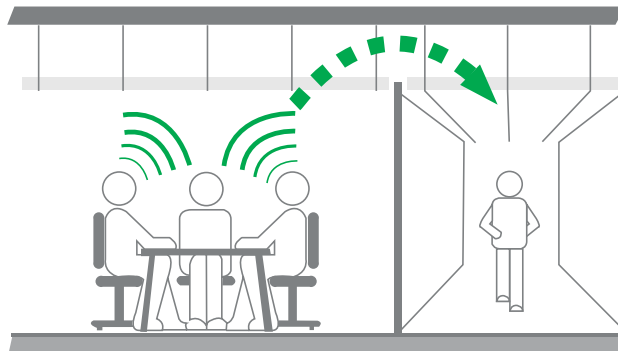

ACOUSTICAL PERFORMANCE DETAILS

		SOUND ABSORPTION		SOUND ATTENUATION
	INFILL	NRC	α_w	CAC
Lay-In Panels	Plain	N/A	N/A	35-40
	Standard Acoustical Fleece	0.45-0.60	-	<20
	Premium Acoustical Fleece	0.65	Class C	<20
	Premium Acoustical Fleece+Rockwool	0.90	Class A	20-25
	Mineral Fiber Board	0.40-0.50	-	30-35
Clip-In Panels	Plain	N/A	N/A	35-40
	Standard Acoustical Fleece	0.45-0.60	-	<20
	Premium Acoustical Fleece	0.70	Class C	<20
	Premium Acoustical Fleece+Rockwool	0.90	Class A	20-25
	Mineral Fiber Board	0.40-0.50	-	30-35

ASTM C423, ASTM E1414 and EN ISO11654 "Standard test method for sound absorption and sound absorption coefficients by the reverberation room"

PRODUCT PERFORMANCE



HUMIDITY

Metal ceilings from USG Boral ME are ideal for fast tract construction as they can be installed early in the building program. The building should be closed but need not to be heated during and after installation.

LIGHT REFLECTANCE









USG Boral ME metal ceiling systems offer a light reflectance performance of LR-1, which can contribute to energy savings.

APPLICATION GUIDE

TILE & PLANK CEILING SYSTEM		TYPICAL USES	AIRPORT	AUDITORIUM	CLEAN ROOMS	EXTERIOR	FACTORIES	GYMNASIUMS	HEALTHCARE	HOTELS	LOBBIES	MUSEUMS	OFFICES	PUBLIC AREAS	RESTAURANTS	SCHOOLS	SHOPPING MALL	SHOWROOM	STORES	
	CLIP-IN		•	•	•	•	•	•	•	•	•	•	•	•	•	•	•	•	•	•
	LAY-IN		•	•			•	•	•	•	•	•	•	•	•	•	•	•	•	•

SYSTEM USG BORAL ME CLIP-IN CEILINGS

SUSPENSION COMPONENTS

DESCRIPTION & MATERIAL	APPLICATION	
Suspension hanger rod	Suspends primary channel from soffit	
Suspension channel	Provides primary support and lateral restraint	
Spring tee bar (Triangle type)	Provides support for clip-in tile flanges, Suspend below suspension channel	
Wire connecting clips	For coupling	
Primary channel brackets	To suspend the primary channels using hangers	
Butterfly clip	Provide easy plenum height adjustment	
L-Trim	22 x 19.5mm - 0.48 thick	
U-Trim	30 x 50 x 30mm - 0.48 thick	



USG BORAL ME CLIP IN

PRODUCT INFORMATION

ITEM NO.	DESCRIPTION	TOTAL THICKNESS	EDGE DETAIL	NRC	COLOUR	SUSPENSION OPTION
AC-11 (6)(7)(8) R (16)(10)(06)	Clip-in panel 300x300mm Alum, Plain	0.60/0.70/0.80mm	Beveled	0.45-0.90	RAL9016/9010/9006	Carrier Connection
ACPA1-11 (6)(7)(8) R (16)(10)(06)	Clip-in panel 300x300mm Alum, Perforated	0.60/0.70/0.80mm	Beveled	0.45-0.90	RAL9016/9010/9006	Carrier Connection
AC-22 (6)(7)(8) R (16)(10)(06)	Clip-in panel 600x600mm Alum, Plain	0.60/0.70/0.80mm	Beveled	0.45-0.90	RAL9016/9010/9006	Carrier Connection
ACPA1-22 (6)(7)(8) R (16)(10)(06)	Clip-in panel 600x600mm Alum, Perforated	0.60/0.70/0.80mm	Beveled	0.45-0.90	RAL9016/9010/9006	Carrier Connection
SC-22 (6)(7) R (16)(10)(06)	Clip-in panel 600x600mm Steel, Plain	0.50/0.60mm	Beveled	0.45-0.90	RAL9016/9010/9006	Carrier Connection
SCPA1-22 (6)(7) R (16)(10)(06)	Clip-in panel 600x600mm Steel, Perforated	0.50/0.60mm	Beveled	0.45-0.90	RAL9016/9010/9006	Carrier Connection
AC-14 (8)(9)(10) R (16)(10)(06)	Clip-in panel 300x1200mm Alum, Plain	0.80/0.90/1.0mm	Beveled	0.45-0.90	RAL9016/9010/9006	Carrier Connection
ACPA1-14 (8)(9)(10) R (16)(10)(06)	Clip-in panel 300x1200mm Alum, Perforated	0.80/0.90/1.0mm	Beveled	0.45-0.90	RAL9016/9010/9006	Carrier Connection
AC-15 (8)(9)(10) R (16)(10)(06)	Clip-in panel 300x1500mm Alum, Plain	0.80/0.90/1.0mm	Beveled	0.45-0.90	RAL9016/9010/9006	Carrier Connection
ACPA1-15 (8)(9)(10) R (16)(10)(06)	Clip-in panel 300x1500mm Alum, Perforated	0.80/0.90/1.0mm	Beveled	0.45-0.90	RAL9016/9010/9006	Carrier Connection
AC-24 (8)(9)(10) R (16)(10)(06)	Clip-in panel 600x1200mm Alum, Plain	0.80/0.90/1.0mm	Beveled	0.45-0.90	RAL9016/9010/9006	Carrier Connection
ACPA1-24 (8)(9)(10) R (16)(10)(06)	Clip-in panel 600x1200mm Alum, Perforated	0.80/0.90/1.0mm	Beveled	0.45-0.90	RAL9016/9010/9006	Carrier Connection
AC-44 (14) R (16)(10)(06)	Clip-in panel 1200x1200mm Alum, Plain	1.4mm	Beveled	0.45-0.90	RAL9016/9010/9006	Carrier Connection
ACPA1-44 (14) R (16)(10)(06)	Clip-in panel 1200x1200mm Alum, Perforated	1.4mm	Beveled	0.45-0.90	RAL9016/9010/9006	Carrier Connection

PERFORATION PATTERNS

The provided thickness in the above table is the Total Coated Thickness (TCT), which includes the Base Material Thickness (BMT) + the thickness of the paint. Panels may be supplied either plain or in a range of perforation patterns with a nominal 12mm plain border. Illustrated below are the most widely used patterns and plain border dimensions are available on request.

Pattern A (Open area: 19.5%)

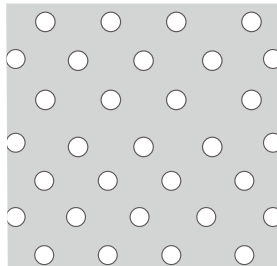

Offset round perforation OD 1.8 mm

Pattern B (Open area: 10%)

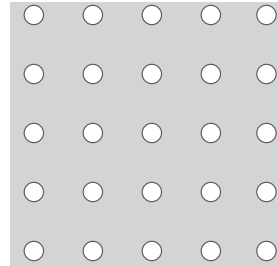

Offset round perforation OD 1.8 mm

Pattern C (Open area: 5.5%)

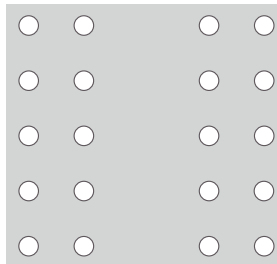

Offset round perforation OD 1.8 mm

Pattern D (Open area: 4.5%)

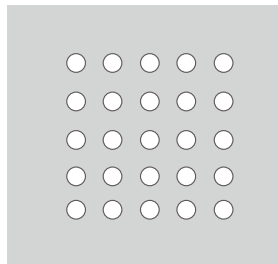

Offset round perforation OD 1.8 mm

Customized patterns are available upon request.

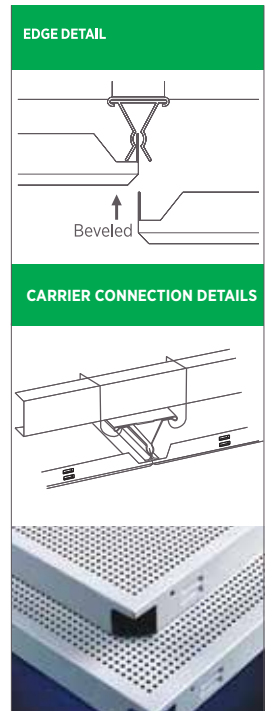

CUT VIEW DETAILS



Perforation of round hole OD 2.3mm is available on the sizes 300 x 300mm, 300x1200mm and 300x1500mm

SYSTEM USG BORAL ME LAY-IN CEILINGS

PRODUCT INFORMATION

ITEM NO.	DESCRIPTION	TOTAL THICKNESS	EDGE DETAIL	NRC	COLOR	SUSPENSION OPTION	
ALN-11 (6)(7)(8) R (16)(10)(06)	Lay-in panel 300x300mm Alum, Plain	0.60/0.70/0.80mm	FL	0.45- 0.90	RAL9016/ 9010/9006	Option 1- DX/DXL Exposed T24 Grid Imperial	
ALPA1N-11 (6)(7)(8) R (16)(10)(06)	Lay-in panel 300x300mm Alum, Perforated	0.60/0.70/0.80mm	FL	0.45- 0.90	RAL9016/ 9010/9006		
ALN-22 (6)(7)(8) R (16)(10)(06)	Lay-in panel 600x600mm Alum, Plain	0.60/0.70/0.80mm	FL	0.45- 0.90	RAL9016/ 9010/9006		
ALPA1N-22 (6)(7)(8) R (16)(10)(06)	Lay-in panel 600x600mm Alum, Perforated	0.60/0.70/0.80mm	FL	0.45- 0.90	RAL9016/ 9010/9006		
SLN-22 (6)(7) R (16)(10)(06)	Lay-in panel 600x600mm Steel, Plain	0.50/0.60mm	FL	0.45- 0.90	RAL9016/ 9010/9006		Option 2- DXLT15 EXPOSED T15 Grid Metric
SLPA1N-22 (6)(7) R (16)(10)(06)	Lay-in panel 600x600mm Steel, Perforated	0.50/0.60mm	FL	0.45- 0.90	RAL9016/ 9010/9006		
ALN-24 (8)(9)(10) R (16)(10)(06)	Lay-in panel 600x1200mm Alum, Plain	0.80/0.90/1.0mm	FL	0.45- 0.90	RAL9016/ 9010/9006		
ALPA1N-24 (8)(9)(10) R (16)(10)(06)	Lay-in panel 600x1200mm Alum, Perforated	0.80/0.90/1.0mm	FL	0.45- 0.90	RAL9016/ 9010/9006		
ALW-11 (6)(7)(8) R (16)(10)(06)	Lay-in panel 300x300mm Alum, Plain	0.60/0.70/0.80mm	SL	0.45- 0.90	RAL9016/ 9010/9006		DX/DXL Exposed T24 Grid Metric
ALPA1W-11 (6)(7)(8) R (16)(10)(06)	Lay-in panel 300x300mm Alum, Perforated	0.60/0.70/0.80mm	SL	0.45- 0.90	RAL9016/ 9010/9006		
ALW-22 (6)(7)(8) R (16)(10)(06)	Lay-in panel 600x600mm Alum, Plain	0.60/0.70/0.80mm	SL	0.45- 0.90	RAL9016/ 9010/9006		
ALPA1W-22 (6)(7)(8) R (16)(10)(06)	Lay-in panel 600x600mm Alum, Perforated	0.60/0.70/0.80mm	SL	0.45- 0.90	RAL9016/ 9010/9006		
SLW-22 (6)(7) R (16)(10)(06)	Lay-in panel 600x600mm Steel, Plain	0.50/0.60mm	SL	0.45- 0.90	RAL9016/ 9010/9006		
SLPA1W-22 (6)(7) R (16)(10)(06)	Lay-in panel 600x600mm Steel, Perforated	0.50/0.60mm	SL	0.45- 0.90	RAL9016/ 9010/9006		
ALW-24 (8)(9)(10) R (16)(10)(06)	Lay-in panel 600x1200mm Alum, Plain	0.80/0.90/1.0mm	SL	0.45- 0.90	RAL9016/ 9010/9006		
ALPA1W-24 (8)(9)(10) R (16)(10)(06)	Lay-in panel 600x1200mm Alum, Perforated	0.80/0.90/1.0mm	SL	0.45- 0.90	RAL9016/ 9010/9006		

SPECIFICATIONS SYSTEM USG LI 200 LAY-IN METAL CEILINGS

T24 LAY IN PANEL DETAIL

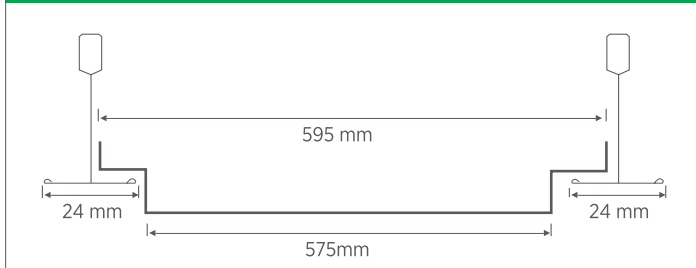

T15 LAY IN PANEL DETAIL

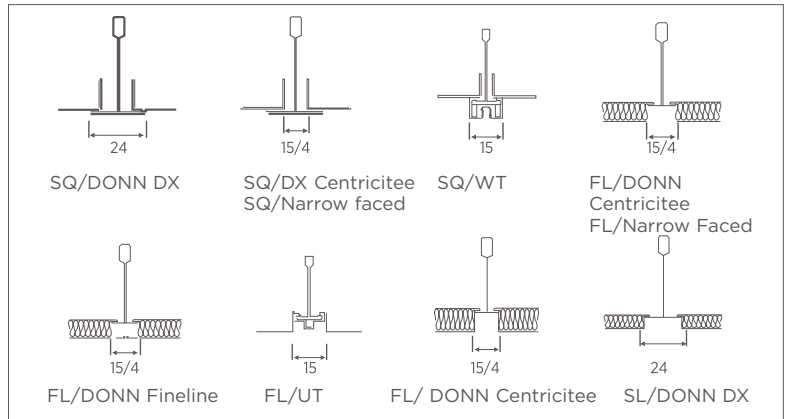
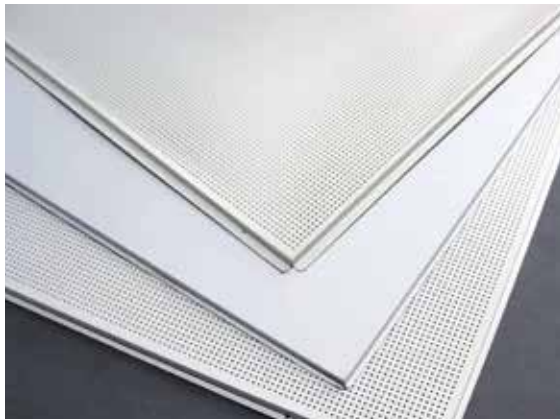
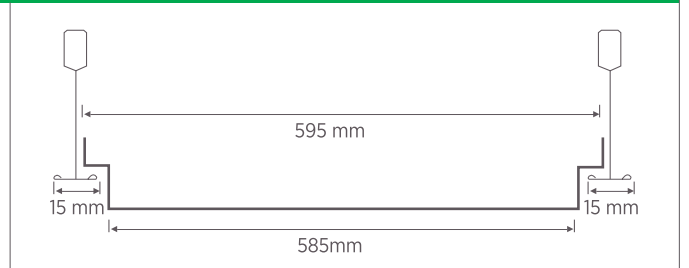

DESCRIPTION

USG Boral Lay-in System is a demountable tile, flush or regular effect system which is particularly suitable for commercial, retail and display areas, where access to the ceiling void is required. Designed to lay in an exposed grid suspension system, either DX, DXT, DXF, OMEGA grid, to form flush or Tegular suspended metal ceiling.

- Strong modular or flush appearance
- A range of module sizes
- Simple to install
- Head fixing
- Sealed-in acoustic infills

ACCESS

Tiles can be simply lifted out of the suspension system to gain access to the ceiling void.

SHAPE

Tiles are squares or rectangular with formed edges to rest on the flanges of the grid system.

SYSTEM MODULES SIZES

Standard nominal tile sizes: 300x300mm, 600x600mm and 600x1200mm.

LOCATION AND RELOCATION OF PARTITIONING

The continuous linear thread form allows the easy location and relocation of partition heads by means of a M6 bolt, without causing damage to the ceiling. To maintain the acoustic attenuation performance, the partitioning contractor in the threaded recess should insert a gasket across the width of the partition head.

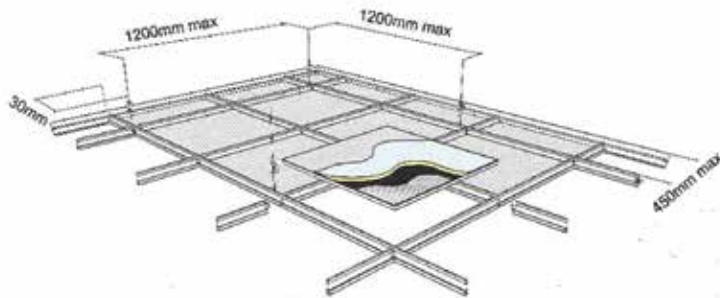
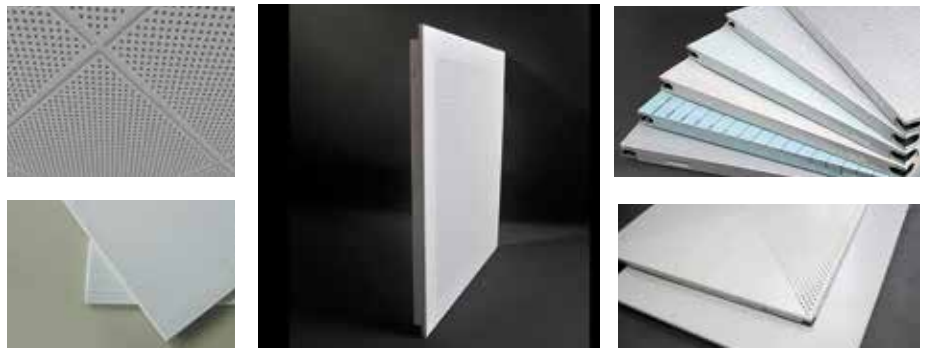

PERFORATION PATTERNS

Panels may be supplied either plain or in a range of perforation patterns with a nominal 12mm plain border. Illustrated below are the most widely used patterns and plain border dimensions are available on request.

Pattern A (Open area: 19.5%)

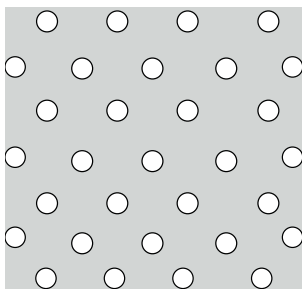

Offset round perforation OD 18 mm

Pattern B (Open area: 10%)

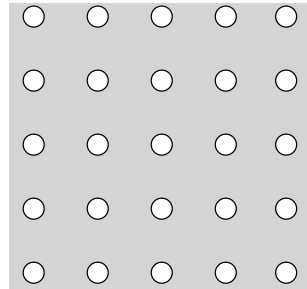

Offset round perforation OD 18 mm

Pattern C (Open area: 5.5%)

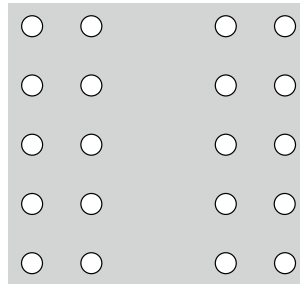

Offset round perforation OD 18 mm

Pattern D (Open area: 4.5%)

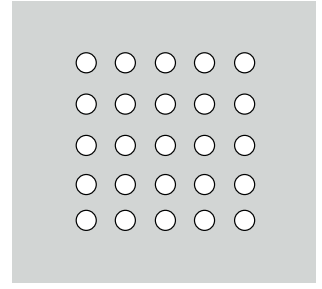

Offset round perforation OD 18 mm

APPLICATION GUIDE SPECIFICATIONS

1.1 SUMMARY

1.2 SUBMITTALS

1.3 REFERENCES

1.4 QUALITY ASSURANCE

1.5 DELIVERY, STORAGE AND HANDLING

1.6 PROJECT CONDITIONS

PART 1: GENERAL

Description of Work: Work of this Section includes, but is not limited to, the following:

- Metal ceiling panels.
- Metal suspension systems.
- Accessories.

Product Data: Submit manufacturer's specifications and installation instructions with Project conditions Submittals materials clearly identified or detailed for each required system.

1. ASTM C635:

Standard specifications for Metal Suspension Systems for Acoustical Tile and Lay-in Panel Ceilings.

2. ASTM C636:

Recommended Practice for Installation of Metal Suspension System for Acoustical Tile and Lay-in Panels.

3. ASTM E119:

Fire Tests of Building Construction and Materials.

4. ASTM C423:

Test Method for Sound Absorption and Sound Absorption Coefficients by the Reverberation Room Method.

5. ASTM E84:

Fire Hazard Classification.

1. Reference Standards:

- ASTM C635, Standard Specifications for Metal Suspension Systems
- ASTM Recommended Practice for Installation of Metal Suspension Systems.

2. Submittals:

Samples: Submit actual samples and technical data for suspension system main tees and cross tees for review.

3. Manufacturer's Data:

System Details: Submit manufacturer's catalogue cuts or standard drawing showing the system's details with project conditions clearly identified and manufacturer's recommended installation instructions.

1. Delivery:

- Deliver materials to site promptly without undue exposure to weather
- Deliver in manufacturer's unopened containers or bundles, fully identified by name, brand, type and grade

2. Inspection:

Promptly inspect delivered materials, file freight claims for damage during shipment, and order replacement materials as required. Any damaged materials shall be promptly removed from the job site

3. Storage:

- Store above ground in dry, ventilated space.
- Protect materials from soiling, rusting and damage.

4. Handling:

Handle in such manner to avoid racking, distortion or physical damage of any kind.

Environmental Requirements:

Do not install the system or any parts until space is enclosed and the weatherproof, wet-work is completed and dry, in addition to the completion of the work above installation, and the maintenance of the space temperature and humidity as designed for occupancy.

1.7 COORDINATION WITH OTHER WORK

1. General:

Coordinate with other work including mechanical and electrical works and partition systems. Installation of conduit and ductwork above suspension system shall be complete before installation of the suspension system.

2. Protection:

- Follow good safety and industrial hygiene practices during handling and installing all the products and systems with personnel to take necessary precautions and wear appropriate personal protective equipment as needed.
- Read Material Safety Data Sheets and related literature for important information on products before installation.
- Contractor will be solely responsible for all personal safety issues during and subsequent to the installation; the architect, specifier, owner and manufacturer will rely on contractor's performance in such regard.

PART 2: MATERIALS

1. Clip-In metal ceiling panels:

Manufactured by USGBORAL ME, Dammam in compliance with the applicable ASTM Standards.

2. Panel finishes

- Refer to page 5 for materials description, size, patterns and finish availability.
- Refer to page 4 for Accesories and Suspension systems.

3. Metal lay-in ceiling panels:

- Manufactured by USGBORAL ME , Dammam, in compliance with the applicable ASTM Satandards.

- Panel finishes:

Refer to page 5 for size, patterns and finish availability.

Refer to page 6 for materials description



APPLICATION GUIDE SPECIFICATIONS

PART 3: EXECUTION

3.1 GENERAL

1. Standard for Ceiling Suspension System Installations: Comply with ASTM C636.
2. Standard for Ceiling Suspension Systems Requiring Seismic Restraint: Comply with ASTM E 580.

3.2 INSPECTION

1. Examine the areas where the ceiling panels are received for conditions that will adversely affect installation. Provide written report on the discrepancies.
2. Do not start work until unsatisfactory conditions are corrected.
3. Work to be concealed: Verify work above ceiling is complete and installed in a manner that will not affect the layout and installation of ceiling panels.
4. Beginning of installation shall signify acceptance of conditions in areas to receive ceiling panels.
5. Fire-rating requirements: Construction above fire-rated assembly shall meet requirements of UL Design specified in 2: Products.

Field dimensions must be verified prior to installation.

3.3 PREPARATION

3.4 INSTALLATION

1. Standard reference: Install ceiling panels and suspension system, including necessary hangers, grillage, splines, and other supporting hardware, in accordance with ASTM C636, and any applicable code requirement.
2. Manufacturer's reference: Install ceiling panels in exposed grid systems supported on all edges, in accordance with the manufacturer's warranty.
3. Drawing reference: Install ceiling panels in accordance with the approved shop drawings.
4. Hanger Wires:
 - Spacing: Space hanger wires on main tees not more than 1.200 mm o.c. a maximum of 1200 mm o.c, attaching hangers directly to the structure above, or as required to support loads
 - Limitations: Do not support wires from mechanical and/or electrical equipment, piping or other equipment occurring above ceiling.
5. Accessories: Install accessories as applicable to meet the project requirements.
6. Install edge moldings and trim of the type indicated at perimeter of acoustical ceiling area and where necessary to conceal edges of acoustical tiles.
7. Install suspension system runners, so that they are shaped as a square and securely interlocked with one another. Remove and replace dented, bent, or kinked members.
8. Panels.
 - For Clip-In panels: install by clipping panels to the underside of the Spring T. After installation, leave 10 removal tools for maintenance.
 - For Lay-in panels: Install by dropping panels down into grid frame from above.

3.5 CLEANING

1. Suspension System: Remove panel material and perform any necessary cleaning maintenance with non-solvent based commercial cleaner.
2. Immediately remove any corrosive substances or chemicals that would attack painted finishes (i.e. wallpaper adhesives).
3. Touch up all minor scratches and spots, as acceptable, or replace damaged sections when touch-up is not permitted.
4. Painting: Repainting of suspension member shall be with high-quality solvent based enamel paint and applied as recommended by the paint manufacturer. Ceiling panels may be touched-up by spraying thinned, non-bridging vinyl-acrylic flat wall paint. The type of paint selected and the method of application can alter the acoustical performance and fire ratings of any acoustical product. Therefore, USGBORAL ME cannot guarantee that the field-painted panels will match the published performance.
5. Removal of debris: Remove all debris resulting from work on this section.

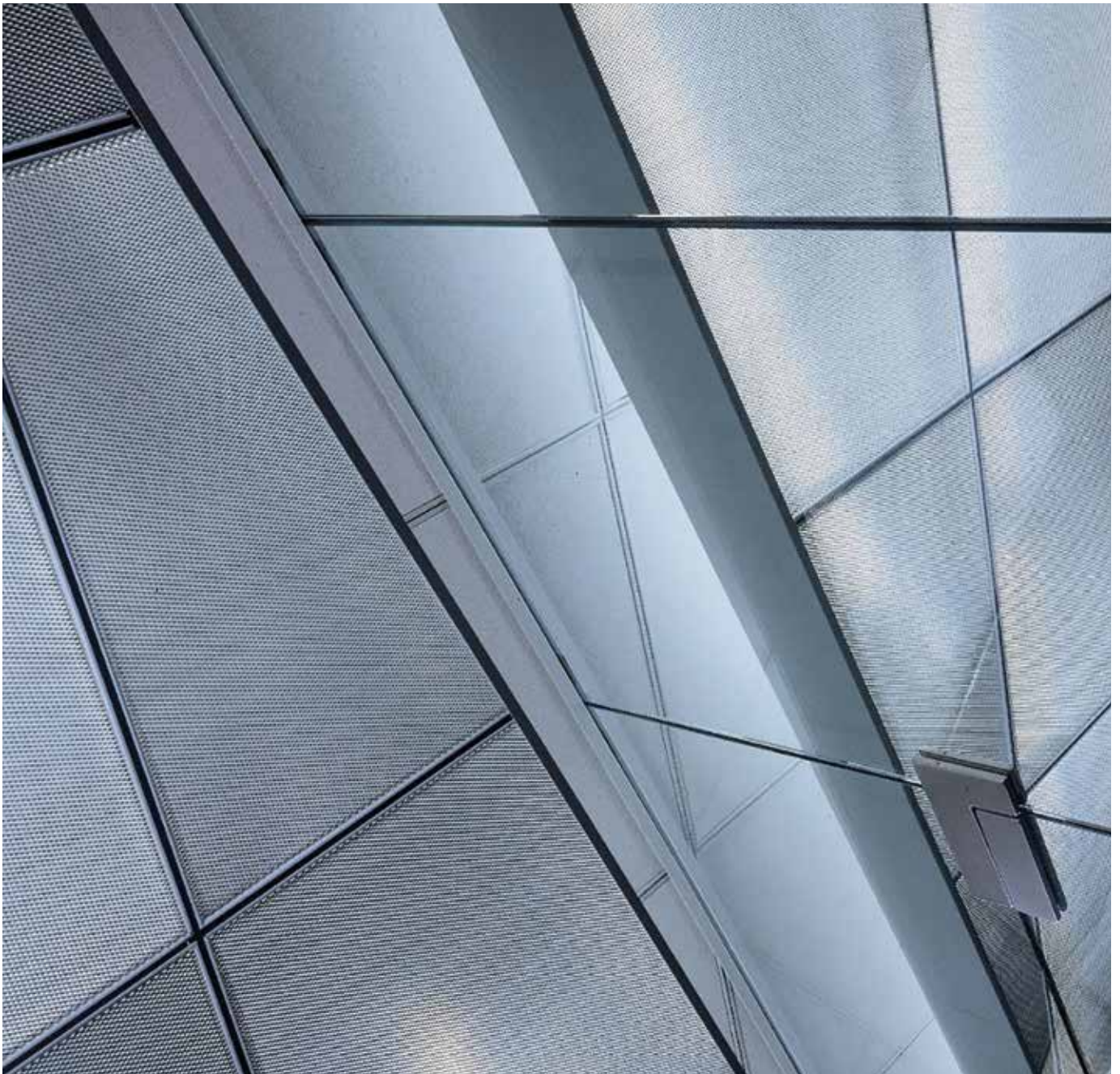



**DONN[®]DX/DXL GRID
SUSPENSION SYSTEM
INSPIRED BY YOU**

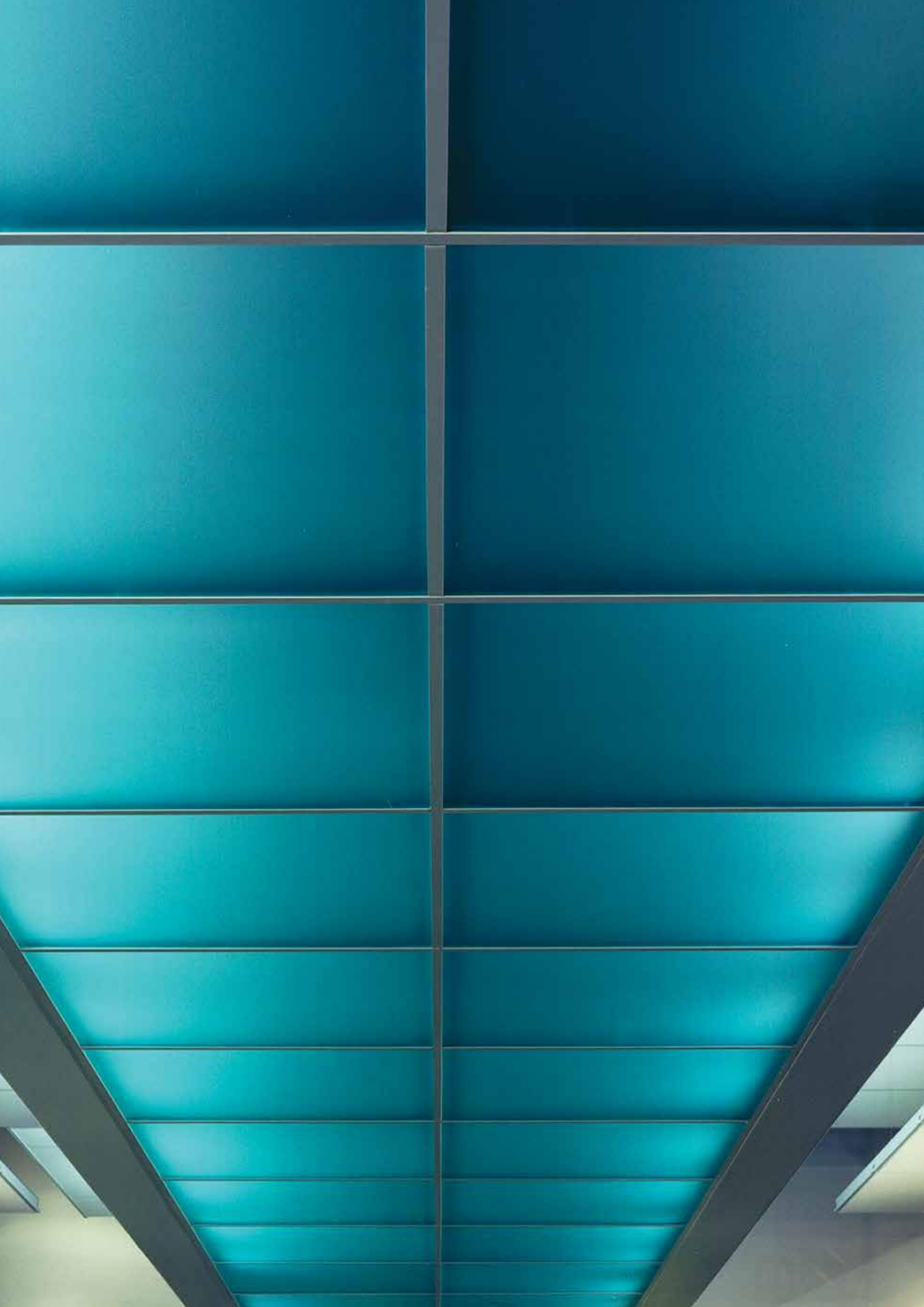

INSTALLING A DONN® GRID SYSTEM

The appearance of a suspended acoustical ceiling is dependent both on the materials used and on the quality of the installation. USG Boral ME manufactures components to meet ASTM C635, BSEN13964, assuring that the material, structural and quality standards are as prescribed. Installation must meet BS8290, assuring proper level and secure attachment as prescribed. Good construction conditions are very important when successfully installing a suspended ceiling. It is recommended that the temperature and humidity range be 14 – 25°C and max. 75% relative humidity. Store materials in a protected area, store tiles on the job at least 3 days prior to installation.

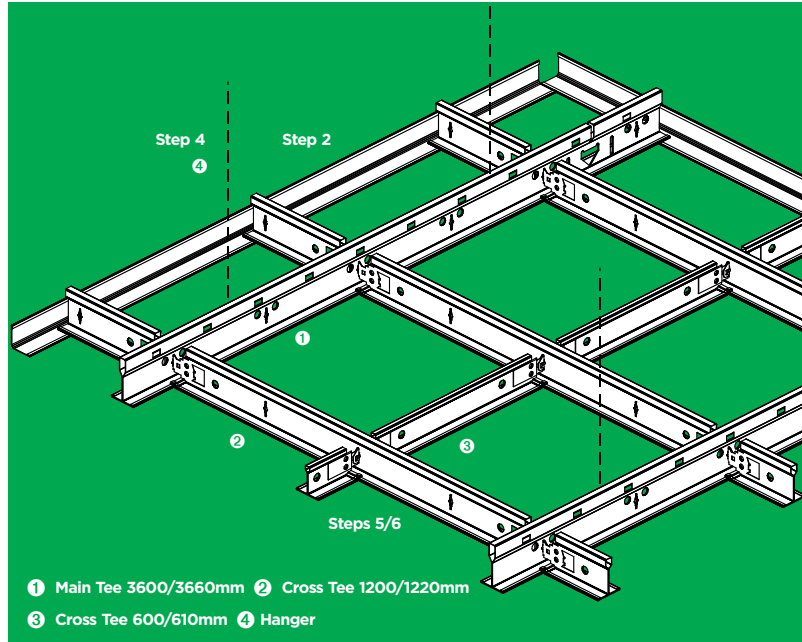

Step 1

Measuring and planning are key first steps in the installation process.

Measurement and placement of the tees will be on center (o.c.), meaning from the center of one to the center of the next. Planning starts with a drawing of the room that shows all walls, including bays, alcoves beams and stairwells. Note which direction the joists (if any) are running, or if architectural drawings necessitate working in one direction or another. Determine the lines for main runners and cross tees in such a way that the tiles that about the wall are at least half a tile (300mm).

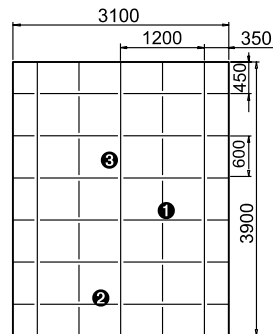

1 Main tee 3600/3660mm 2 Cross Tee 1200/1220mm
3 Cross Tee 600/610mm

Step 2

Mark the desired ceiling height (maintaining at least 70mm clearance below the lowest duct, pipe or beam.)

Measure and mark the walls at all corners above the installation level (= add the height of the wall angle to the desired ceiling height.) Snap a chalk line and test for level. Measuring down from joists or up from the floor is not recommended, since neither may be level. Install wall angle with top edge of angle at the chalk line, spacing appropriate fixings 450mm o.c. or closer. Cut and mitre outside and inside angles at 45°, fitting them snugly together. Alternatively, simply butt angles at corner (as in system illustration).

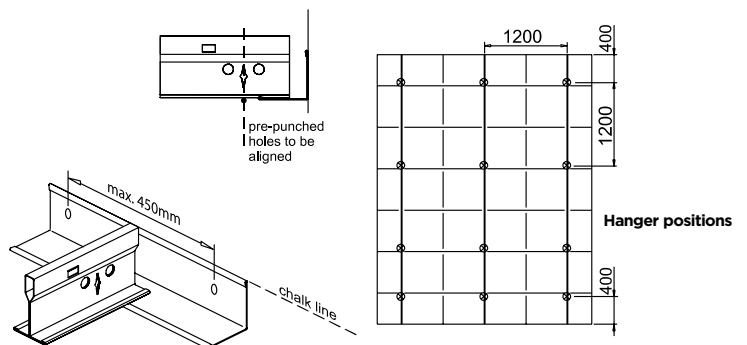

Step 3

To confirm level, stretch a string until taut along the positions which the main tee will occupy.

Inserting a nail between the wall and the wall angle at marked locations serves as a good anchor for this purpose. Stretch another string across the room where the first row of cross tees will be located. This identifies where the first pre-punched slots need to fall. Check to be sure the cross tee string is at 90° to the main tee string via the 3-4-5 method. Install the hangers at 1200mm o.c. above the lines of the main runners. Fix to the structure above using appropriate plugs, screws or other devices.

Step 4

Attach the main runners to the hangers.

In each row, trim the main tee so that the cross-tee slot will line up with the cross-tee string. Mount main tees, resting the cut end of the main tee on the wall angle. The cut end of the main runner should be about 5mm away from the wall.

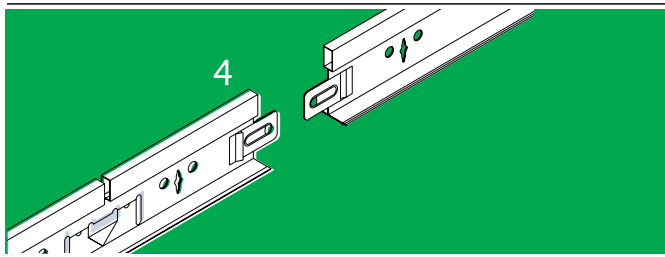

Step 5

Install cross tees, assuring that they are adequately connected to main tees (they “click” in place when properly seated).

Where two cross tees intersect in the same slot, insert second cross-tee end to the left of the first. Where a cross-tee is installed without an opposing cross-tee, a nail should be slipped into the opening of the cross-tee clip to maintain the pull-out value for the cross-tee.

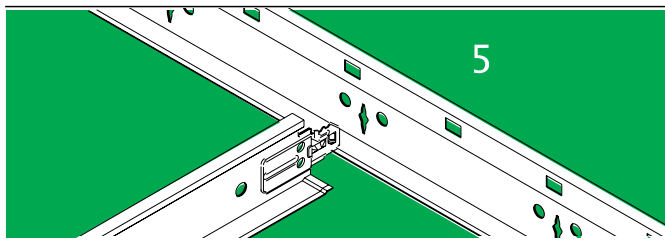

Step 6

Lay in panels, beginning at one corner and completing row by row.

Tilt each panel up through the opening and lower it to rest squarely on all four tees.

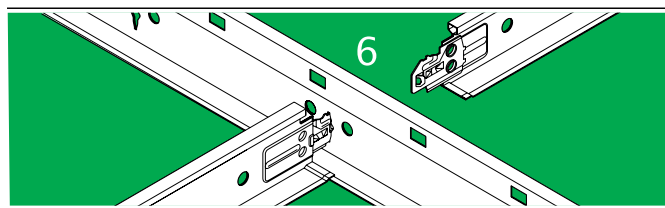

Step 7

Removal as easy as installation. Just grasp the main tee with one thumb under the main tee-cross tee connection and, pushing up with the thumb, give the main tee a quick, short twist. That's all it takes - no tools needed. The strong clip means that the grid can be reinstalled straightaway with no tearing or bending of the clip.

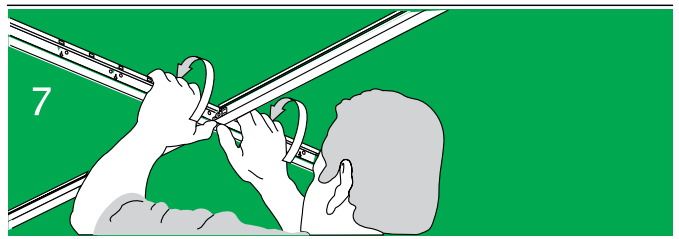

Step 8

Main tee demounting

Using a straight shearing motion, push with your left hand and pull with your right hand to disconnect the main runner splice. Note: do not twist the splice during the removal procedure

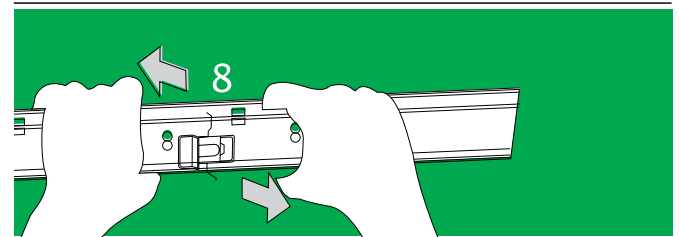

Other installation tips

- A.** Cut tees with aviation snips, first the stem and then the flanges.
- B.** Cut mineral fiber panels with utility knife and straight edge, cutting the face first. Cut panels should be at least 15mm larger than the opening.
- C.** To install panels around obstructions, draw their exact locations on the panels and cut out. Then cut the panel in two parts through the largest section of the cut-out to enable fitting.
- D.** To trim for Shadowline edge, use a utility knife to cut the panel, first at the face, then from the edge, to the same depth as Shadowline. If windows, stairwells, etc., extend above the ceiling plane, build suitable valances and attach wall angle.

DONN® EXPOSED GRID

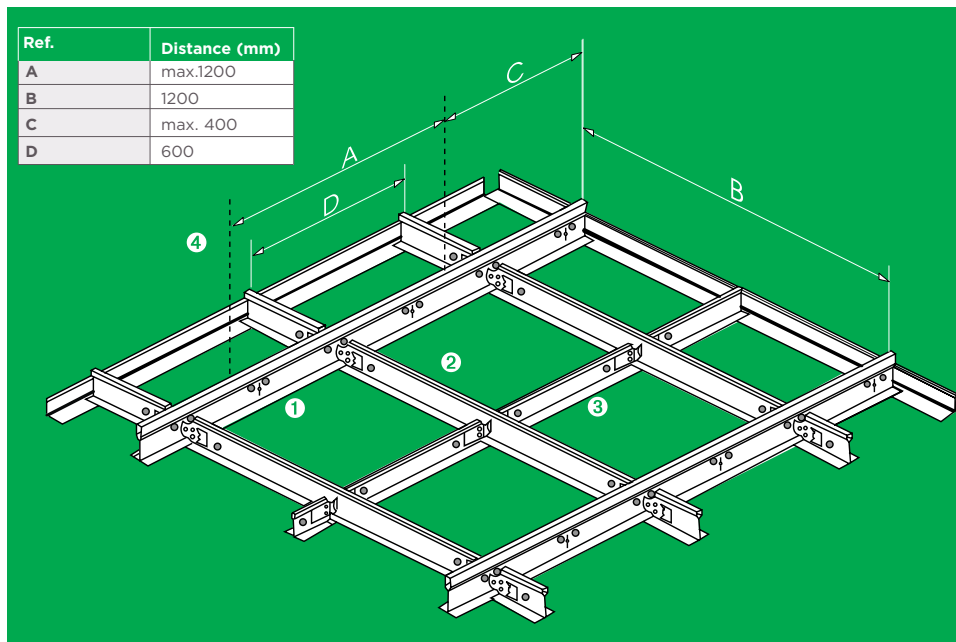
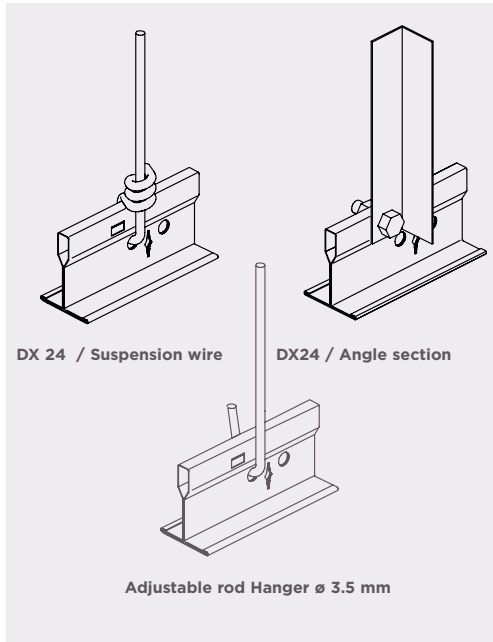

Materials

All USG Boral ME suspension systems feature a body and cap made of hot-dip galvanized steel. To ensure that the cap remains attractive and rust-free for long term, manufacturing includes an exclusive four-step coating process that outperforms the competition in paint adhesion and corrosion resistance, as proven by industry-standard salt spray tests conducted by an Independent laboratory.

For our extreme environments we offer our grid system, with hot-dipped galvanized steel body and painted aluminum cap for additional corrosion and humidity resistance.

Product Information

Nr	Description	Item reference	
		Metric	Imperial
1	Main Runner	DX3600LD	DX3660LD
2	Long Cross Tee	DX1200LM	DX1220LM
3	Short Cross Tee	DX600LM	DX610LM
4	Wall Angle	MT3600-MS3600-MS164L-MTA3600	
5	Hanger	35RHXXX-38RHXXX	

Quantity

Linear meter required per square meter

For construction layouts use the following formulas to calculate linear meters (LM) per square meter (m²)

• Main tee

(1/ Main Tee centers)

eg. if MT at 1200mm centers $\frac{1}{1.2} = 0.83\text{LM}/\text{m}^2$

• Cross tee

(1/ Cross Tee centers)

eg. if CT at 600mm centers $\frac{1}{0.60} = 1.67\text{LM}/\text{m}^2$

Note: These calculations do not allow for wastage, damage or irregularities but are intended as an informative guideline to assist with the calculation of product required for a given area (in m²)

System characteristics:

- Exposed 24mm system
- The most widely used grid system in the world
- Safe, fast and simple to install & easily accessible
- Maximum economy and design simplicity
- Cross-tees with override-ends resist twisting and give Professionally finished look with no exposed steel edges
- Patented QUICK-RELEASE™ clip design: demountable without tools
- Compatible with square edge and SLB edge ceiling tiles
- Audible Click means you know when tees are connected
- Exceed load compliance specifications as per ASTM C 635
- Available in metric and imperial sizes

DONN® DX24 LIGHT DUTY

Main Runner DX3600LD

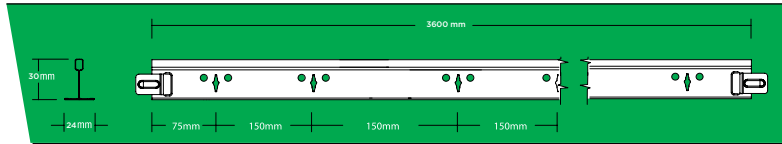

Long Cross Tee DX1200LM

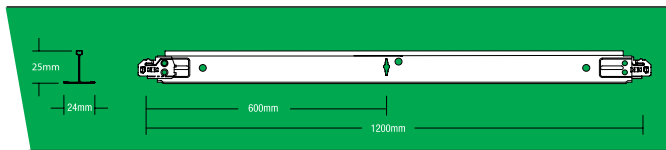

Short Cross Tee DX600LM



Maximum allowed weight of tiles per m² of ceiling

Hanger distance (mm)	Module			
	Main runner at 1200mm		Main runner at 600mm	
800	20.90	21.20	-	-
1000	20.90	21.20	41.90	42.90
1200	10.50	10.50	20.90	20.90
1500	4.10	4.20	8.70	8.90

Note: The load per m² must be distributed uniformly (no point loads) over the ceiling area. After loading, the deflection of any grid component will remain within the maximum deflection per span as stated in BS: 8290: 1991, provided the grid layout is as presented in the sketch.

Please consult USG for other layouts, load or hanger distance.

Tile edge supported



DX24 / SLT DX24 / SQ DX24 / SLB

Cross section

Main tee and cross tee connection.

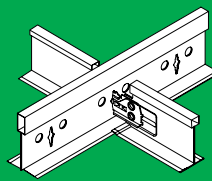

Clip to Clip Security

Clip to Clip Connection

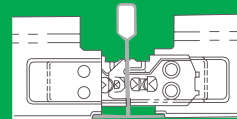

180 kg

Hold Down Clip

Partition head fixing using revolve clips with DX24.

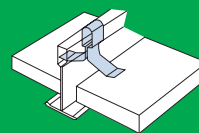

Spring clip

Spring clip application.

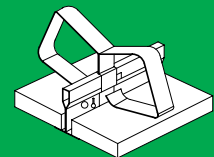

Specification DONN® DX24-LD

Grid shall be DONN® DX24 exposed grid system, hot dipped galvanized steel 'T' section with pre-painted capping. Table width 24mm. To suit variable module sizes, most typically 600 x 600mm and 1200 x 600mm. Main runners: 30 x 24mm, ref DX3600LD shall be normally spaced at 1200mm centers and suspended from the structure or soffit using pre-straightened 2.6mm diameter HDG steel wire hangers, or adjustable rod hanger ø 35 mm, ref 35 RHXXXX at typically 1200mm centers. First hanger shall be no more than 450mm from the perimeter. Main runners joined end on by means of the integral splice. Splice connections shall be supported within 150mm with a hanger, and shall be staggered across the ceiling area.

Cross tees: 1200mm cross tees, 25 x 24mm ref DX1200LM, shall be installed perpendicular between the main runners at 600mm centers to form a 1200 x 600mm module. If applicable, 600mm cross tees, 25 x 24mm ref DX600LM, shall be installed perpendicular between the 1200mm cross tees to form a 600 x 600mm module. All cross tees feature a 'joggled' end detail.

Perimeter trims: 22mm x 19.5mm / 19 x 9 x 9 x 19mm/20 x 20 x 20 x 20mm painted HDG steel angle trim, ref MT3600/MS3600/MS164L/MTA3600, fixed to perimeter wall using fixings appropriate to the structure at maximum 450mm centers. Corners shall normally be finished with a lapped or butt joint.

Hangers - Seismic Application: Shall be from pre straightened 2.6mm diameter HDG steel wire, ref DSW2. Hangers shall be fixed through holes in stalk or bulb of main runner and wrapped around itself a minimum of 3 times. Alternatively, hangers can be formed from 25 x 25mm HDG steel angle section, or ø 35mm rod hanger, fixed to main runners using appropriate self drilling screws or nut and bolt fixings. Hangers shall be normally spaced at 1200mm centers although alternative spacings are acceptable provided maximum loadings stated above are not exceeded. Hangers to be fixed to structure or soffit using fixings appropriate to the structure or soffit.

Hold down clips: Where applicable, these shall be non removable type clips. These generally will only be required in certain fire protecting assemblies or where there is a risk of tile uplift. Where fitted, these should be applied to all grid members at a rate of 1 clip per 600mm of tile edge.

DONN® DX24 INTERMEDIATE DUTY

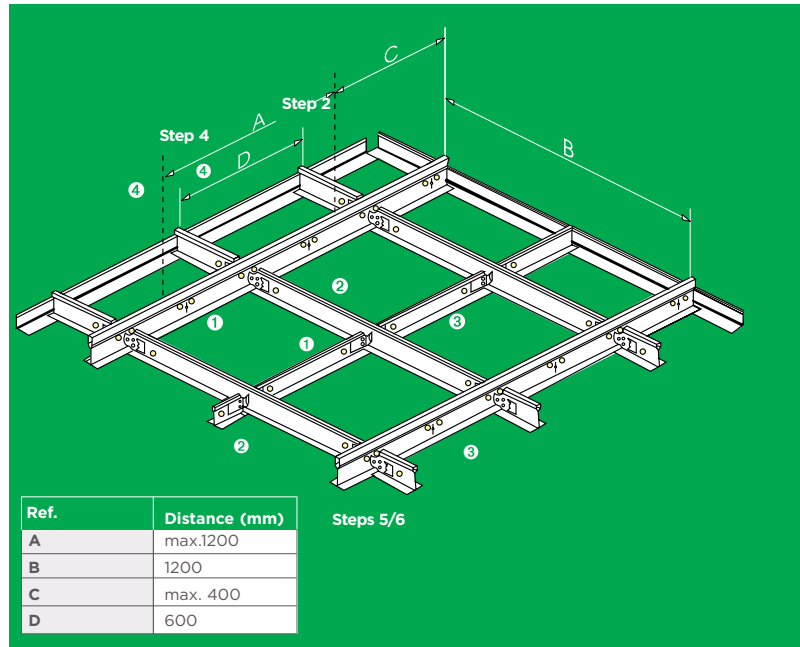
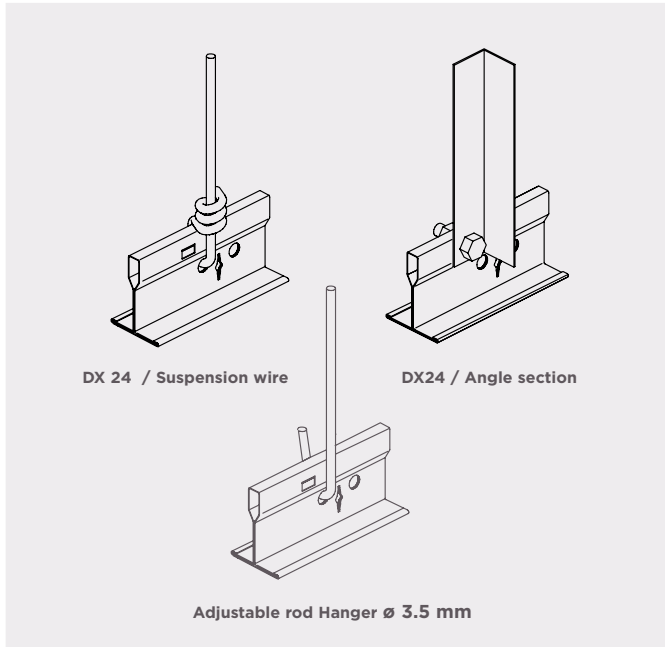

Materials

All USG Boral ME suspension systems feature a body and cap made of hot-dip galvanized steel. To ensure that the cap remains attractive and rust-free for long term, manufacturing includes an exclusive four-step coating process that outperforms the competition in paint adhesion and corrosion resistance, as proven by industry-standard salt spray tests conducted by an independent laboratory. For our extreme environments we offer our grid system, with hot-dipped galvanized steel body and painted aluminum cap for additional corrosion and humidity resistance.

Product Information

Nr	Description	Item reference	
		Metric	Imperial
1	Main Runner	DX3600IM	DX3660IM
2	Long Cross Tee	DX1200LM	DX1220LM
3	Short Cross Tee	DX600LM	DX610LM
4	Wall Angle	MT3600-MS3600-MS164L-MTA3600	
5	Hanger	35RHXXX-38RHXXX	

Quantity

Linear meter required per square meter
For construction layouts use the following formulas to calculate linear meters (LM) per square meter (m²)

• **Main tee**

(1/ Main Tee centers)

eg. if MT at 1200mm centers $\frac{1}{1.2} = 0.83LM/m^2$

• **Cross tee**

(1/ Cross Tee centers)

eg. if CT at 600mm centers $\frac{1}{0.60} = 1.67LM/m^2$

Note: These calculations do not allow for wastage, damage or irregularities but are intended as an informative guideline to assist with the calculation of product required for a given area (in m²)

System characteristics:

- Exposed 24mm system
- The most widely used grid system in the world
- Safe, fast and simple to install & easily accessible
- Maximum economy and design simplicity
- Cross-tees with override-ends resist twisting and give professionally finished look with no exposed steel edges
- Patented QUICK-RELEASE™ clip design: demountable without tools
- Compatible with square edge and SLB edge ceiling tiles
- Audible Click means you know when tees are connected
- Exceed load compliance specifications as per ASTM C 635
- Available in metric and imperial sizes

Main Runner DX3600IM

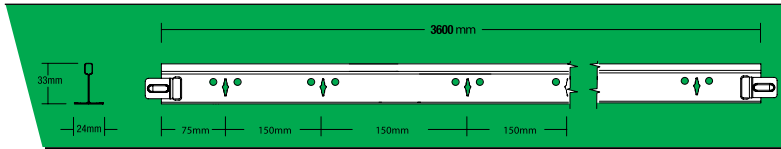

Long Cross Tee DX1200LM

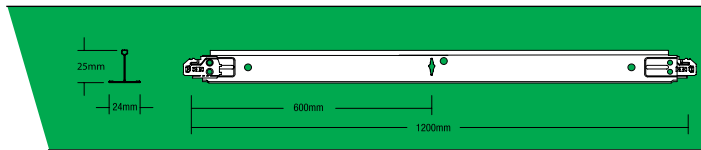

Short Cross Tee DX600LM

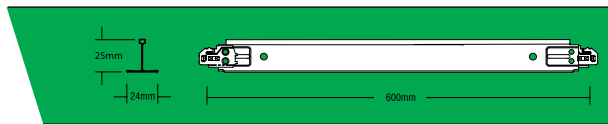

Maximum allowed weight of tiles per m² of ceiling

Hanger distance (mm)	Module			
	Main runner at 1200mm		Main runner at 600mm	
800	600 x 600	600 x 1200	600 x 600	600 x 1200
1000	23.2	23.5	46.5	47.6
1200	11.6	11.6	23.2	23.4
1500	4.5	4.6	9.7	9.9
<p>Note: The load per m² must be distributed uniformly (no point loads) over the ceiling area. After loading, the deflection of any grid component will remain within the maximum deflection per span as stated in BS: 8290: 1991, provided the grid layout is as presented in the sketch.</p> <p>Please consult USG for other layouts, load or hanger distance.</p>				

Tile edge supported



DX24 / SLT DX24 / SQ DX24 / SLB

Cross section

Main tee and cross tee connection.

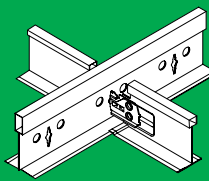

Clip to Clip Security

Clip to Clip Connection

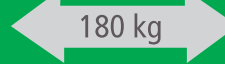
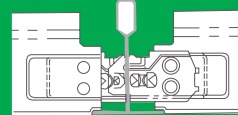

Hold Down Clip

Partition head fixing using revolve clips with DX24.

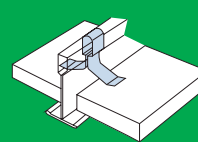

Spring clip

Spring clip application.

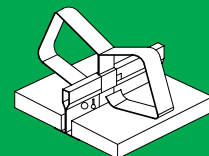

Specification DONN® DX24-IM

Grid shall be DONN® DX24 exposed grid system, hot dipped galvanized steel < T > section with pre-painted capping. Table width 24mm. To suit variable module sizes, most typically 600 x 600mm and 1200 x 600mm. Main runners: 33 x 24mm, ref DX3600IM shall be normally spaced at 1200mm centers and suspended from the structure or soffit using pre-straightened 2mm diameter HDG steel wire hangers, ref on adjustable rod hanger ø 3.5 , ref 35 RHXXX at typically 1200mm centers. First hanger shall be no more than 450mm from the perimeter. Main runners joined end on by means of the integral splice. Splice connections shall be supported within 150mm with a hanger, & shall be staggered across the ceiling area.

Cross tees: 1200mm cross tees, 25 x 24mm ref DX1200LM, shall be installed perpendicular between the main runners at 600mm centers to form a 1200 x 600mm module. If applicable, 600mm cross tees, 25 x 24mm ref DX600LM, shall be installed perpendicular between the 1200mm cross tees to form a 600 x 600mm module. All cross tees feature a 'joggled' end detail.

Perimeter trims: 22mm x 19.5mm/ 19 x 9 x 9 x 19mm/ 20 x 20 x 20 x 20mm painted HDG steel angle trim, ref MT3600/MS3600/MS164L /MTA3600, fixed to perimeter wall using fixings appropriate to the structure at maximum 450mm centers. Corners shall normally be finished with a lapped or butt joint.

Hangers - Seismic Application: Shall be from pre straightened 2mm diameter galvanized wire hanger, ref 35RHXXXX. Hangers shall be fixed through holes in stalk or bulb of main runner and wrapped around itself a minimum of 3 times. Alternatively, hangers can be formed from 25 x 25mm HDG steel angle section, on 35 ø mm rod hanger fixed to main runners using appropriate self drilling screws or nut and bolt fixings. Hangers shall be normally spaced at 1200mm centers although alternative spacings are acceptable provided maximum loadings stated above are not exceeded. Hangers to be fixed to structure or soffit using fixings appropriate to the structure or soffit.

Hold down clips: Where applicable, these shall be non removable type clips. These generally will only be required in certain fire protecting assemblies or where there is a risk of tile uplift. Where fitted, these should be applied to all grid members at a rate of 1 clip per 600mm of tile edge.

DONN® DX24 HEAVY DUTY - STANDARD

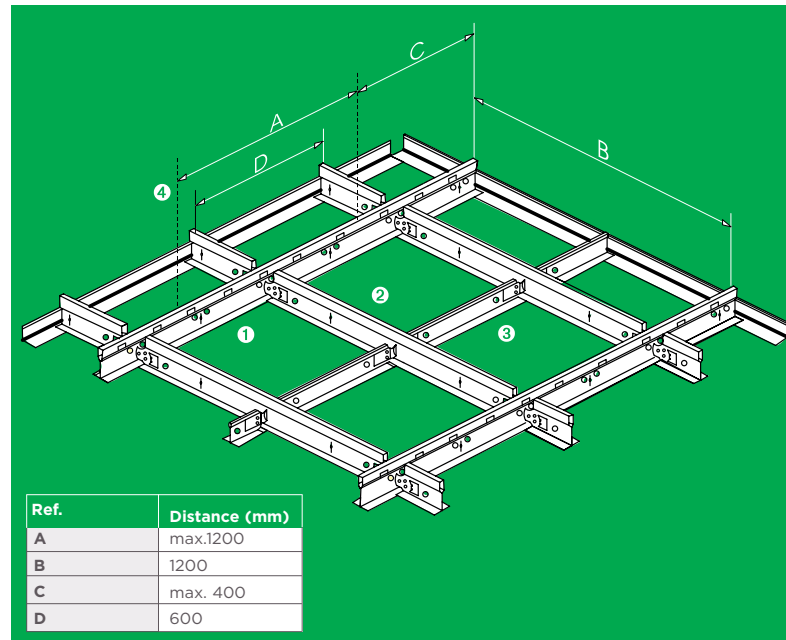
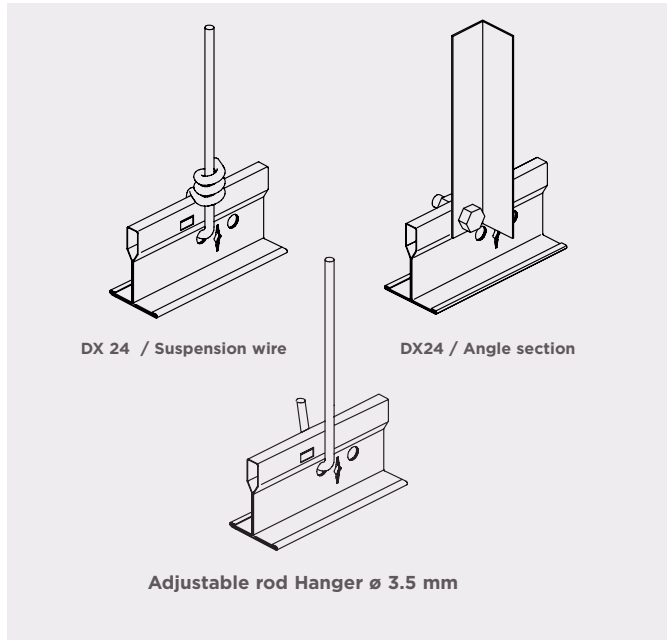

Materials

All USG Boral ME suspension systems feature a body and cap made of hot-dip galvanized steel. To ensure that the cap remains attractive and rust-free for long term, manufacturing includes an exclusive four-step coating process that outperforms the competition in paint adhesion and corrosion resistance, as proven by industry-standard salt spray tests conducted by an independent laboratory. For our extreme environments we offer our grid system, with hot-dipped galvanized steel body and painted aluminum cap for additional corrosion and humidity resistance.

Product Information

Nr	Description	Item reference	
		Metric	Imperial
1	Main Runner	DX3600H	DX3660H30
2	Long Cross Tee	DX1200H30 / DX1200 LM	DX1220H30 / DX 1220LM
3	Short Cross Tee	DX600H30 / DX600LM	DX610H30 / DX610LM
4	Wall Angle	MT3600-MS3600-MS164L-MTA3600	
5	Hanger	35RHXXXX	

Quantity

Linear meter required per square meter
For construction layouts use the following formulas to calculate linear meters (LM) per square meter (m²)

• **Main tee**

(1/ Main Tee centers)
eg. if MT at 1200mm centers $\frac{1}{1.2} = 0.83LM/m^2$

• **Cross tee**

(1/ Cross Tee centers)
eg. if CT at 600mm centers $\frac{1}{0.60} = 1.67LM/m^2$

Note: These calculations do not allow for wastage, damage or irregularities but are intended as an informative guideline to assist with the calculation of product required for a given area (in m²)

System characteristics:

- Exposed 24mm system
- The most widely used grid system in the world
- Safe, fast and simple to install & easily accessible
- Maximum economy and design simplicity
- Cross-tees with override-ends resist twisting and give Professionally finished look with no exposed steel edges
- Patented QUICK-RELEASE™ clip design: demountable without tools
- Compatible with square edge and SLB edge ceiling tiles
- Audible Click means you know when tees are connected
- Exceed load compliance specifications as per ASTM C635
- Available in metric and imperial size

Main Runner DX3600H

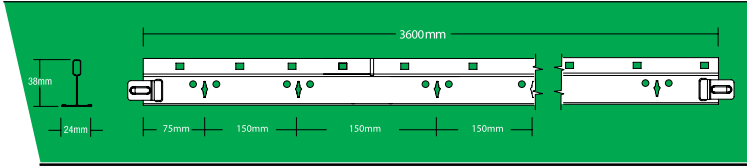

Long Cross Tee DX1200H30 / DX1200LM

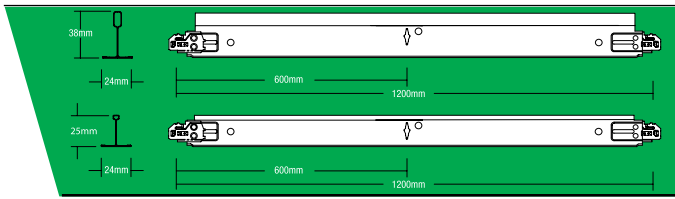

Short Cross Tee DX600H30 / DX 600LM

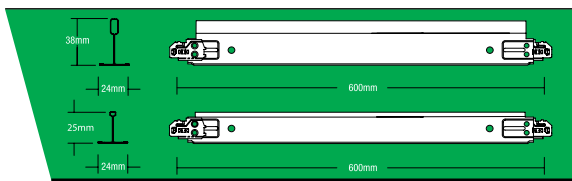

Maximum allowed weight of tiles per m² of ceiling

Hanger distance (mm)	Module			
	Main runner at 1200mm		Main runner at 600mm	
	600 x 600	600 x 1200	600 x 600	600 x 1200
800	23.2	23.5	-	-
1000	23.2	23.5	46.8	48.6
1200	12.3	12.4	24.6	25.2
1500	4.5	4.6	9.7	9.9

Note: The load per m² must be distributed uniformly (no point loads) over the ceiling area. After loading, the deflection of any grid component will remain within the maximum deflection per span as stated in BS: 8290: 1991, provided the grid layout is as presented in the sketch.

Please consult USG for other layouts, load or hanger distance.

Specification DONN® DX24-H

Grid shall be DONN® DX24 exposed grid system, hot dipped galvanized steel ' T ' section with pre painted capping. Table width 24mm. To suit variable module sizes, most typically 600 x 600mm and 1200 x 600mm. Main runners: 38 x 24mm, ref DX3600H shall be normally spaced at 1200mm centers and suspended from the structure or soffit using pre-straightened 2mm diameter HDG steel wire hangers, at typically 1200mm centers. First hanger shall be no more than 450mm from the perimeter. Main runners joined end on by means of the integral splice. Splice connections shall be supported within 150mm with a hanger, and shall be staggered across the ceiling area.

Cross tees: 1200mm cross tees, 38 x 24mm ref DX 1200H30 and 25 x 24mm ref DX1200LM, shall be installed perpendicular between the main runners at 600 mm centers to form a 1200 x 600mm module. If applicable, 600mm cross tees, 25 x 24mm ref DX600LM and 38 x24mm ref DX600H30, shall be installed perpendicular between the 1200mm cross tees to form a 600 x 600mm module. All cross tees feature a 'joggled' end detail.

Perimeter trims: 22mm x 19.5mm/19x9x9x19mm / 20 x 20 x 20 x

Tile edge supported



DX24 / SLT DX24 / SQ DX24 / SLB

Cross section

Main tee and cross tee connection.

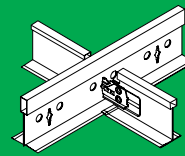

Clip to Clip Security

Clip to Clip Connection

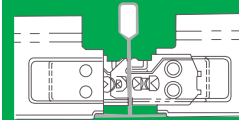

DX24 / revoc clip

Partition head fixing using revoc clips with DX24.

Spring clip

Spring clip application.

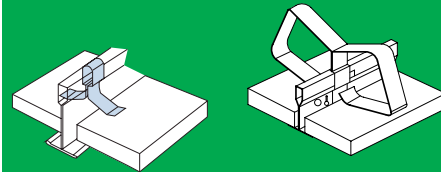

20mm painted HDG steel angle trim, ref MT3600/MS3600/MS164L, fixed to perimeter wall using fixings appropriate to the structure at maximum 450mm centers. Corners shall normally be finished with a lapped or but joint.

Hangers - Seismic Application: Shall be from pre straightened 2.6mm diameter HDG steel wire, ref 35RHXXXX. Hangers shall be fixed through holes in stalk or bulb of main runner and wrapped around itself a minimum of 3 times. Alternatively, hangers can be formed from ø 3.5mm adjustable rod hanger on 25 x 25mm HDG steel angle section, ref DGA5, fixed to main runners using appropriate self drilling screws or nut and bolt fixings. Hangers shall be normally spaced at 1200mm centers although alternative spacings are acceptable provided maximum loadings stated above are not exceeded. Hangers to be fixed to structure or soffit using fixings appropriate to the structure or soffit.

Hold down clips: Where applicable, these shall be non removable type clips. These generally will only be required in certain fire protecting assemblies or where there is a risk of tile uplift. Where fitted, these should be applied to all grid members at a rate of 1 clip per 600mm of tile edge.

DONN® DXL24 HEAVY DUTY - FIRE RATED

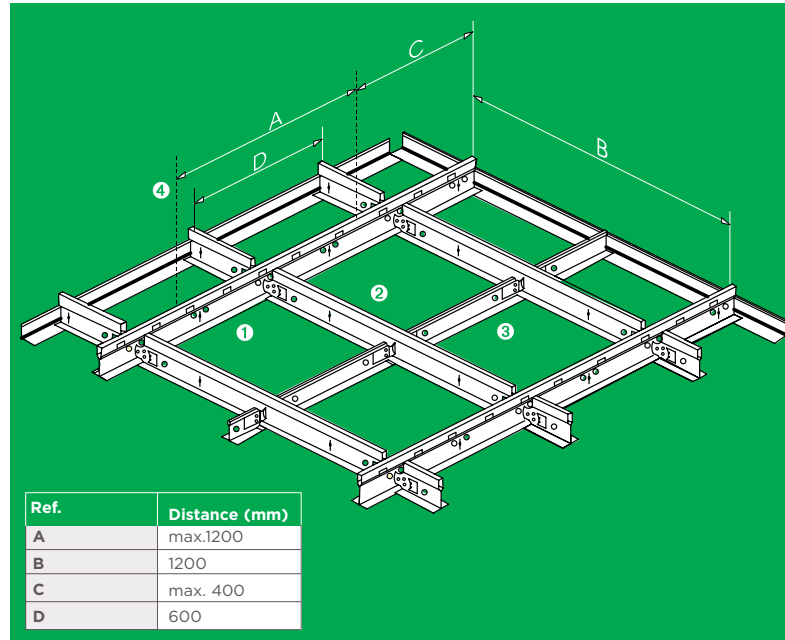
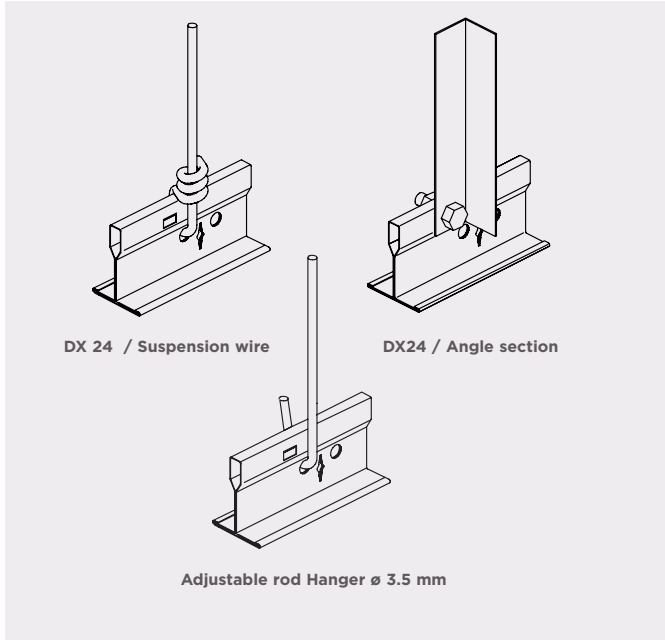

Materials

All USG Boral ME suspension systems feature a body and cap made of hot-dip galvanized steel. To ensure that the cap remains attractive and rust-free for long term, manufacturing includes an exclusive four-step coating process that outperforms the competition in paint adhesion and corrosion resistance, as proven by industry-standard salt spray tests conducted by an independent laboratory. For our extreme environments we offer our grid system, with hot-dipped galvanized steel body and painted aluminum cap for additional corrosion and humidity resistance.

Product Information

Nr	Description	Item reference	
		Metric	Imperial
1	Main Runner	DXL3600	DXL3660
2	Long Cross Tee	DX1200H30	DX1220H30
3	Short Cross Tee	DX600H30	DX610H30
4	Wall Angle	MT3600-MS3600-MS164L-MTA3600	
6	Hanger	35RHXXXX-38RHXXX	

Quantity

Linear meter required per square meter
For construction layouts use the following formulas to calculate linear meters (LM) per square meter (m²)

• **Main tee**

(1/ Main Tee centers)

eg. if MT at 1200mm centers $\frac{1}{1.2} = 0.83LM/m^2$

• **Cross tee**

(1/ Cross Tee centers)

eg. if CT at 600mm centers $\frac{1}{0.60} = 1.67LM/m^2$

Note: These calculations do not allow for wastage, damage or irregularities but are intended as an informative guideline to assist with the calculation of product required for a given area (in m²)

System characteristics:

- Exposed 24mm system
- The most widely used grid system in the world
- Safe, fast and simple to install & easily accessible
- Maximum economy and design simplicity
- Cross-tees with override-ends resist twisting and give professionally finished look with no exposed steel edges
- Patented QUICK-RELEASE™ clip design: demountable without tools
- Compatible with square edge and SLB edge ceiling tiles
- Audible Click means you know when tees are connected
- Exceed load compliance specifications as per ASTM C635
- Available in metric and imperial size

Main Runner DXL3600

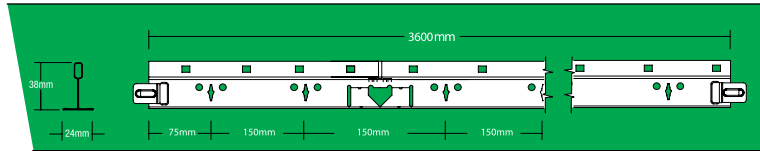

Long Cross Tee DX1200H30

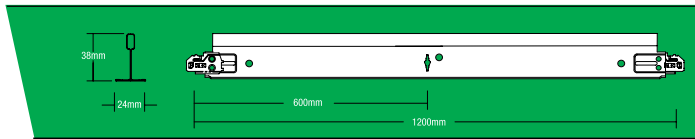

Short Cross Tee DX600H30

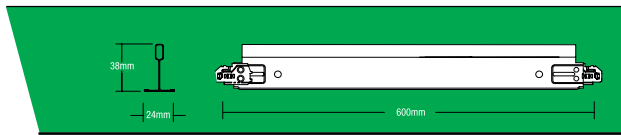

Maximum allowed weight of tiles per m² of ceiling

Hanger distance (mm)	Module			
	Main runner at 1200mm		Main runner at 600mm	
800	23.7	23.9	-	-
1000	23.7	23.9	55.9	56.3
1200	12.8	12.9	26.3	26.6
1500	4.6	4.8	10	10.3

Note: The load per m² must be distributed uniformly (no point loads) over the ceiling area. After loading, the deflection of any grid component will remain within the maximum deflection per span as stated in BS: 8290: 1991, provided the grid layout is as presented in the sketch.

Please consult USG for other layouts, load or hanger distance.

Specification DONN® DXL24

Grid shall be DONN® DX24 exposed grid system, hot dipped galvanized steel ' T ' section with pre-painted capping. Table width 24mm. To suit variable module sizes, most typically 600 x 600mm and 1200 x 600mm. Main runners: 38 x 24mm, ref DXL3600 shall be normally spaced at 1200mm centers and suspended from the structure or soffit using pre-straightened 2mm diameter HDG steel wire hangers, at typically 1200mm centers. First hanger shall be no more than 450mm from the perimeter. Main runners joined end on by means of the integral splice. Splice connections shall be supported within 150mm with a hanger, and shall be staggered across the ceiling area.

Cross tees: 1200mm cross tees, 38 x 24mm ref DX1200H30, shall be installed perpendicular between the main runners at 600mm centers to form a 1200 x 600mm module. If applicable, 600mm cross tees, 38 x 24mm ref DX600H30 shall be installed perpendicular between the 1200mm cross tees to form a 600 x 600mm module. All cross tees feature a 'joggled' end detail.

Tile edge supported



DX24 / SQ DX24 / SLT DX24 / SLB

Cross section

Main tee and cross tee connection.

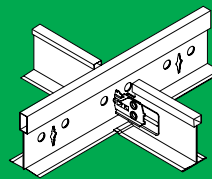

Fire protection

DX main tees are designed to expand at the fire lance in the event of a fire (shown here). This maintains the structural integrity of the ceiling and holds tiles in place.

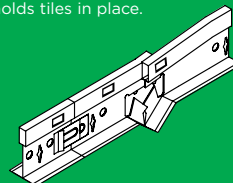

Hold Down Clip

Partition head fixing using revolve clips with DX24.

Spring clip

Spring clip application.

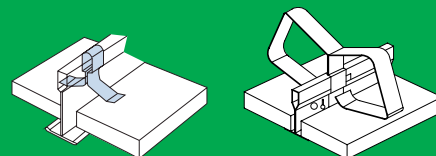

Perimeter trims: 22mm x 19.5mm/19x9x9x19mm painted HDG steel angle trim, ref MT3600/MS3600/MS164/MTA3600, fixed to perimeter wall using fixings appropriate to the structure at maximum 450mm centers. Corners shall normally be finished with a lapped or butt joint.

Hangers - Seismic Application: Shall be from pre straightened 2mm diameter HDG steel wire, ref 35RHXXXX. Hangers shall be fixed through holes in stalk or bulb of main runner and wrapped around itself a minimum of 3 times. Alternatively, hangers can be formed from ø 3.5mm adjustable rod hanger on 25 x 25mm HDG steel angle section, fixed to main runners using appropriate self drilling screws or nut and bolt fixings. Hangers shall be normally spaced at 1200mm centers although alternative spacings are acceptable provided maximum loadings stated above are not exceeded. Hangers to be fixed to structure or soffit using fixings appropriate to the structure or soffit.

Hold down clips: Where applicable, these shall be non removable type clips. These generally will only be required in certain fire protecting assemblies or where there is a risk of tile uplift. Where fitted, these should be applied to all grid members at a rate of 1 clip per 600mm of tile edge.

DONN® DX15 CENTRICITEE

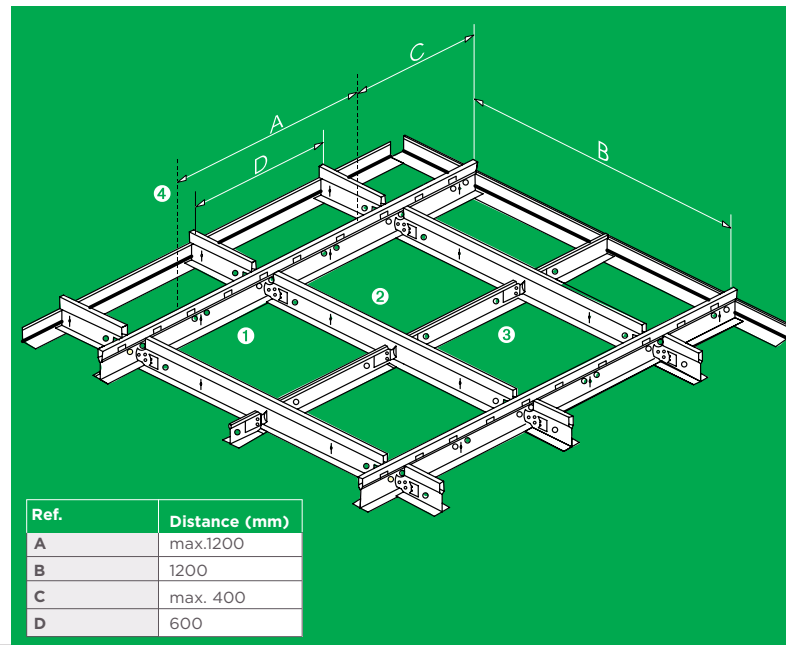
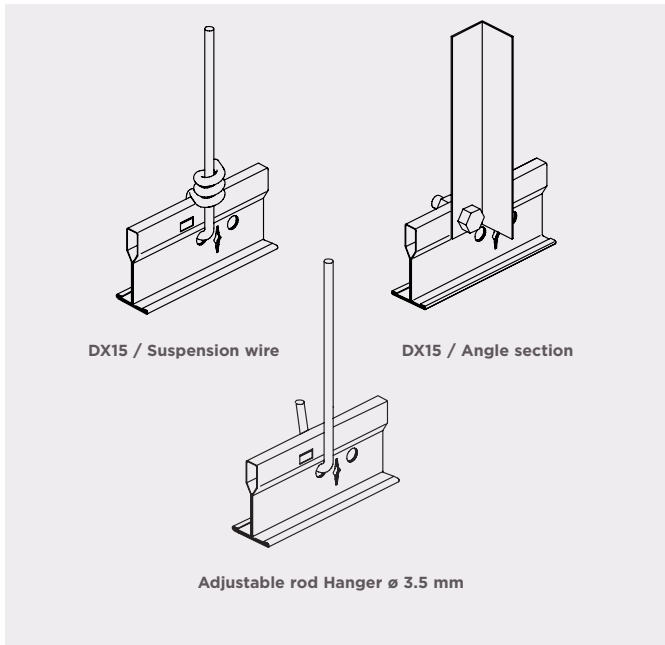

Materials

All USG Boral ME suspension systems feature a body and cap made of hot-dip galvanized steel. To ensure that the cap remains attractive and rust-free for long term, manufacturing includes an exclusive four-step coating process that outperforms the competition in paint adhesion and corrosion resistance, as proven by industry-standard salt spray tests conducted by an independent laboratory. For our extreme environments we offer our grid system, with hot-dipped galvanized steel body and painted aluminum cap for additional corrosion and humidity resistance.

Product Information

Nr	Description	Item reference	
		Metric	Imperial
1	Main Runner	DXT15-3600M	DXT15-3660IM
2	Long Cross Tee	DXT15-1200M	DXT15-1220IM
3	Short Cross Tee	DXT15-600M	DXT15-610IM
4	Wall Angle	M93600-MS3600	
5	Hanger	35RHXXX-38RHXXX	

Quantity

Linear meter required per square meter
For construction layouts use the following formulas to calculate linear meters (LM) per square meter (m²)

• **Main tee**

(1/ Main Tee centers)
eg. if MT at 1200mm centers $\frac{1}{1.2} = 0.83LM/m^2$

• **Cross tee**

(1/ Cross Tee centers)
eg. if CT at 600mm centers $\frac{1}{0.60} = 1.67LM/m^2$

Note: These calculations do not allow for wastage, damage or irregularities but are intended as an informative guideline to assist with the calculation of product required for a given area (in m²)

System characteristics:

- Exposed 15mm system
- Narrow table grid for subtle visual effect
- Cross-tees with override-ends resist twisting and give professionally finished look with no exposed steel edges
- Patented QUICK-RELEASE™ clip design: easy to remove without tools
- Safe, fast and simple to install and easily accessible
- Standard jogged (overriding) cross tee system
- Suitable for FLB edge and most “face cut design” ceiling tiles
- Designed for fire rated ceilings
- Lay-on Cross Tees resist twist and gapping • Audible Click means you know when tees are connected
- Exceed load compliance specifications as per ASTM C635
- Available in metric in imperial size

Main Runner DXT15-3600M

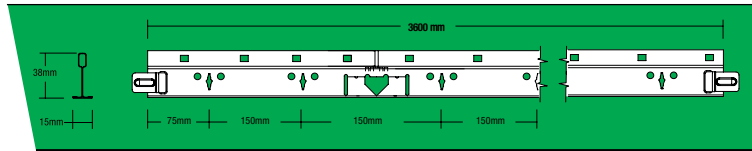

Long Cross Tee DXT15-1200M

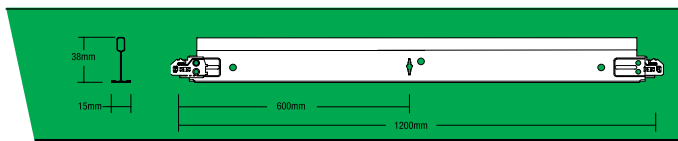

Short Cross Tee DXT15-600M

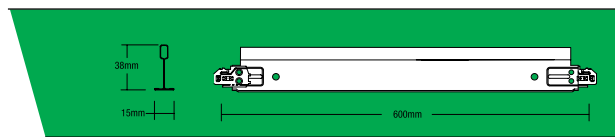

Maximum allowed weight of tiles per m² of ceiling

Hanger distance (mm)	Module			
	Main runner at 1200mm		Main runner at 600mm	
800	24.0	24.2	-	-
1000	24.0	24.2	54.0	54.2
1200	12.4	12.5	25.5	25.7
1500	4.5	4.7	9.8	10.0

Note: The load per m² must be distributed uniformly (no point loads) over the ceiling area. After loading, the deflection of any grid component will remain within the maximum deflection per span as stated in BS: 8290: 1991, provided the grid layout is as presented in the sketch.

Please consult USG for other layouts, load or hanger distance.

Specification DONN® DXLT15

Grid shall be DONN® DX15 exposed grid system, hot dipped galvanized steel 'T' section with pre-painted capping. Table width 15mm. To suit variable module sizes, most typically 600 x 600mm and 1200 x 600mm. Main runners: 38 x 15mm, ref DXT15-3600M shall be normally spaced at 1200mm centers and suspended from the structure or soffit using pre-straightened 2mm diameter HDG steel wire hangers, at typically 1200mm centers. First hanger shall be no more than 450mm from the perimeter. Main runners joined end on by means of the integral splice. Splice connections shall be supported within 150mm with a hanger, and shall be staggered across the ceiling area.

Cross tees: 1200mm cross tees, 38 x 15mm ref DXT15-1200M, shall be installed perpendicular between the main runners at 600mm centers to form a 1200 x 600mm module. If applicable, 600mm cross tees, 38 x 15mm ref DXT15-600M shall be installed perpendicular between the 1200mm cross tees to form a 600 x 600mm module. All cross tees feature a 'joggled' end detail.

Tile edge supported



DX15 / FL DX15 / FLB

Cross section (joggled)

Main tee and cross tee connection.

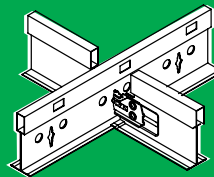

Cross section (butt cut)

Main tee and cross tee connection.

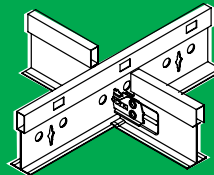

Fire protection

DX main tees are designed to expand at the fire lance in the event of a fire (shown here). This maintains the structural integrity of the ceiling and holds tiles in place.

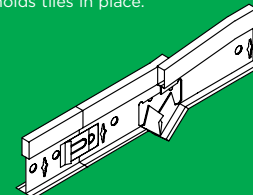

Perimeter trims: 15mm x 24 mm/19x9x9x19mm painted HDG steel angle trim, ref M93600/MS3600, fixed to perimeter wall using fixings appropriate to the structure at maximum 450mm centers. Corners shall normally be finished with a lapped or butt joint.

Hangers - Seismic Application: Shall be from pre straightened 2mm diameter HDG steel wire, ref 35RHXXXX. Hangers shall be fixed through holes in stalk or bulb of main runner and wrapped around itself a minimum of 3 times. Alternatively, hangers can be formed from 25 x 25mm HDG steel angle section, on ø 3.5mm rod hanger fixed to main runners using appropriate self drilling screws or nut and bolt fixings. Hangers shall be normally spaced at 1200mm centers although alternative spacings are acceptable provided maximum loadings stated above are not exceeded. Hangers to be fixed to structure or soffit using fixings appropriate to the structure or soffit.

Hold down clips: Where applicable, these shall be non removable type clips. These generally will only be required in certain fire protecting assemblies or where there is a risk of tile uplift. Where fitted, these should be applied to all grid members at a rate of 1 clip per 600mm of tile edge.



DONN® EXPOSED GRID

DONN®
CENTRICITEE
15mm
EXPOSED
GRID

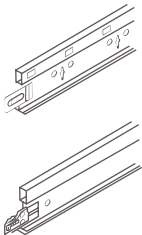

15mm Tee System

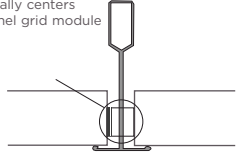

	PROFILE	PRODUCT	PROFILE HEIGHT	COMPONENT LENGTH	THICKNESS	PANEL EDGE OPTIONS
MAIN TEE	 Deep	Main Tee-Centricitee Heavy Duty- Fire Rated	38mm	3600/3660mm	0.38mm	A,B,C,D
CROSS TEE	 Deep	Cross Tee (Heavy) Cross Tee (Heavy)	38mm 38mm	1200mm 600mm	0.30mm	A,B,C,D
	A Square Edge (SQ) ²	B Fineline Bevel Edge (FLB)	C Fineline (FL)	D Interline Tapered (ILT)	Patented self centering device in cross tees automatically centers ceiling panel grid module	
USG Boral ME Panel Edge Detail						

Fire Rated Option

DONN® DXT15 is available only as a Fire Rated option providing protection up to 2 hours, subject to assembly design

Main Tee (Fire Rated)

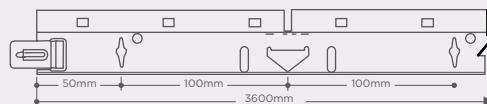

**DONN® DX
24mm
EXPOSED GRID**



24mm Tee System

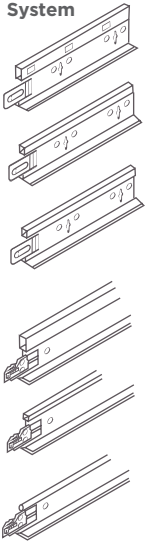

	PROFILE	PRODUCT	PROFILE HEIGHT	COMPONENT LENGTH	THICKNESS	PANEL EDGE OPTIONS
MAIN TEE	Deep	Heavy-Standard	38mm	3600/3660mm	0.30mm	A,B,C,D
		Fire Rated	38mm		0.38mm	A,B,C,D
	Medium	Intermediate Duty	33mm	3600/3660mm	0.30mm	A,B,C,D
		Light Duty	30 mm		0.30mm	A,B,C,D
CROSS TEE	Deep	Fire Rated	38mm	1200/1220mm	0.30mm	A,B,C,D
		Fire Rated	38mm	600/610mm		A,B,C,D
	Medium	Intermediate Duty	33mm	1200/1220mm	0.30mm	A,B,C,D
		Intermediate Duty	33mm	600/610mm		A,B,C,D
	Shallow	Light Duty	25.5mm	1200/1220mm	0.30mm	A,B,C,D
		Light Duty	25.5mm	600/610mm		A,B,C,D
	A Square Edge (SQ)	B Shadowline Tapered (SLT)	C Shadowline (SL)	D Shadowline Bevel (SLB)		
USG Boral ME Panel Edge Detail						

Fire Rated Option

DONN® DXL is available as a Fire Rated option providing protection up to 2 hours, subject to assembly design

Main Tee (Fire Rated)

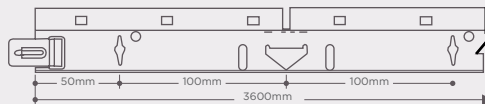

USG BORAL ME LIMITED

Loadings - DONN® DX 24mm Exposed Grid

Ceiling Mass - Kg/m²

Use of Maximum Allowable Gross Ceiling Weight Charts:

- Determine the maximum allowable ceiling weight for the chosen Main Tee and hanger spacings from Graph.
- Determine the maximum allowable ceiling weight for the chosen Cross Tee spacing from table.
- The maximum allowable gross weight is the lower of the values from step 1 and 2.
- Note that any heavy lighting, or other mechanical fixtures should be independently supported.
- Seismic considerations for in-plane loads may take precedence in determining the required section (refer USG Boral ME Representative for details).

CROSS TEES		
DONN DX	Cross Tee Spacing (m)	
Cross Tee Type	0.6	1.2
DX600L M	40.0	29.5
DX1200H 30	28.0	14.0
DX1200L M	9.8	4.9

NOTES:

- Values are based on simple span tests in accordance with recognized International Standard ASTM C635. Higher values can often be attained by allowing for the effect of continuous spans, the actual increase being subject to span arrangements. Please contact USG Boral ME Interiors for guidance.
- For cross-nogged configurations e.g.: where a 1200x600 mm panel runs parallel with the main tee, the spacing values should be used as for 1200x1200mm module.
- Where main tees are at 1200mm centers, creating a 600x600mm configuration does not significantly increase load carrying limits.

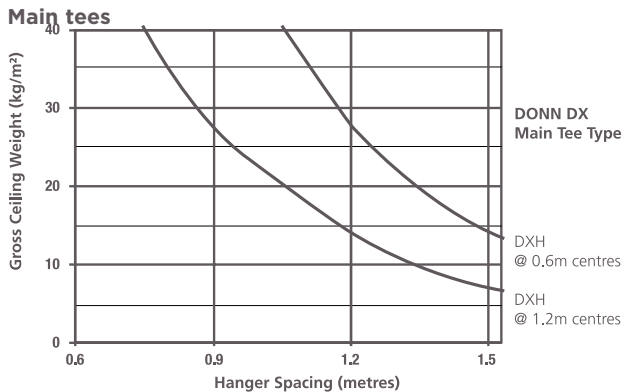

Uniform Loads - kg/lm (linear metre)

Uniform loads are loads that are transferred evenly along a given tee. The maximum load is the combined load on both sides of the tee.

Example:

A 1200 x 600 light fitting weighing 12.6 kg applies a load of 3.5 kg/lm (1.2 + 0.6 + 1.2 + 0.6 = 3.6 lm therefore 12.6 kg / 3.6 lm = 3.5 kg/lm) A 1200 x 600 ceiling panel weighing 3.6 kg applies a load of 1 kg /lm The combined load of light and ceiling panel is 4.5 kg/lm. The maximum allowable uniform load is the lesser of either main or cross tee values

DONN DX Component	Uniform Load kg/lm
Main Tee	
DX3600H	16.8
DX3600IM*	11.6
Cross Tee	
DX600LM	35.4
DX1200LM	16.7
DX1200LM	5.9

* Hanger spacing @ 1.2m centres

Point Loads - kg

Point loads are loads that transfer to a tee at a single point (or several points) over a very small area. The weakest point is assumed to be mid span. main tees are based on a 1200mm span.

The maximum allowable point load is the lesser of either main or cross tee values.

DONN DX Component	Point Load kg
Main Tee	
DX3600H	7.9
DX3600IM*	7.0
Cross Tee	
DX600LM	13.2
DX1200LM	7.9
DX1200LM	4.1

* Hanger spacing @ 1.2m centres

Lighting Installation DONN® DX 24mm Exposed Grid

DONN® DX

As worldwide leaders in acoustical ceiling systems, USG Boral ME Interior works with the major lighting manufacturers to ensure system compatibility is maintained. The following guidelines are designed to assist in the correct specification and installation of light fittings in USG Boral ME's DONN® Exposed Grid and acoustical ceiling systems.

Luminaire Positioning

Typical recessed pan fitting arrangements are shown below. Main Tees at 1200mm centers are shown horizontal, with suspension at 1200mm centers.

- Refer to Loadings (page 108) for maximum allowable point loads, uniform loads and gross ceiling loads depending on type of luminaire and DONN® grid selected. Where luminaire weight exceeds point or uniform load maximums consider:
 - A higher specifications DONN® grid option if applicable (refer to Loadings page 108 this brochure to ensure compliance).
 - Independent support from structure.
 - Additional suspension points as shown below, or similar.

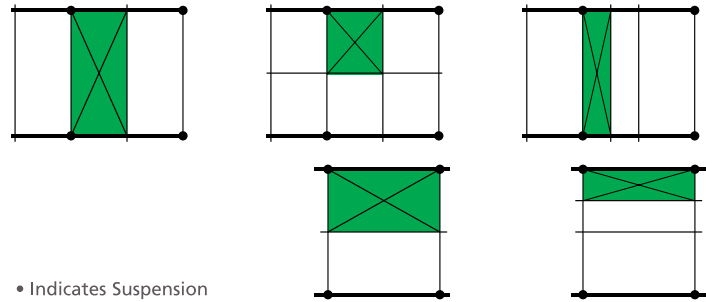

• Indicates Suspension

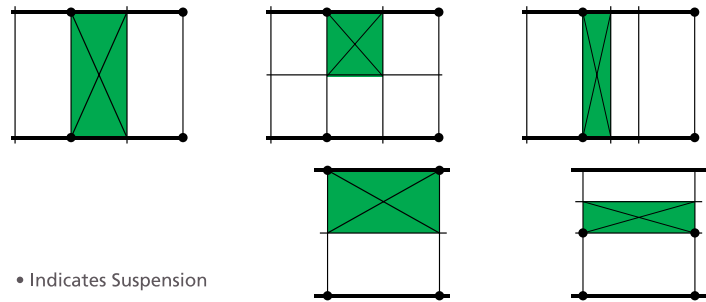

• Indicates Suspension

DONN® Grid Profiles

When recessed pan fittings use the top of the DONN® tee bulb for support, use the same height tee profiles for even support.

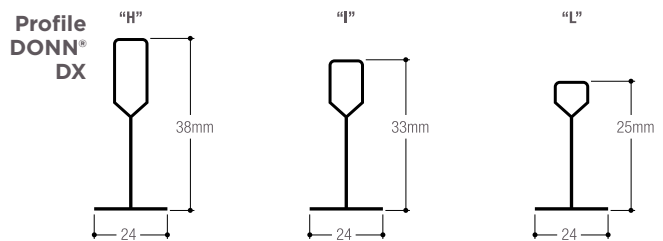

Ceiling panel Mounted Fittings light fittings mounted through USG Boral ME acoustical ceiling panels shall not rely on the ceiling panel for support. Their weight shall be transferred back to the grid by:

- Simple supports across the back of the ceiling panel.
- Simple supports onto the top of the tee bulb.
- An additional rigid panel across the back of the ceiling panel.

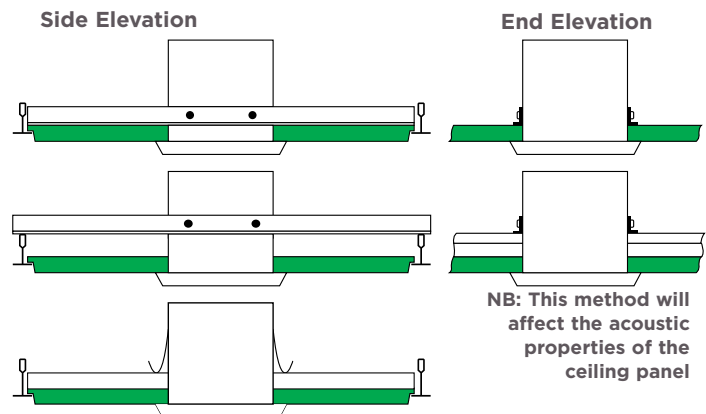

GRID EDGE DETAILS

DONN® DX is the most widely specified grid in Middle East. It includes a wide range of profiles and colors and is fully compatible with all USG Boral ME ceiling tiles as well as most third party brands. Precision design and quality manufacturing ensure both structural and aesthetic integrity in all ceiling designs. USG Boral ME offers the following suspension system and edge details options. Select a suspension system and match it with a corresponding panel edge details, or vice versa, to assure proper system fit and assembly.

Grid system	Edge detail	Square (SQ)	Shadowline Tapered (SLT)	Shadowline (SL)	FineLine (FL)	Pedestal	Shiplap	BESK	Designer (FL)
DONN DX24 DONN DX24K DONN DXE24 Espace									
DONN DX15									
DONN Meridian DXM									
DONN Finline DXF									
DONN Concealed T, Z									
DONN Concealed C, L									
DONN DX35 DONN DXE35 Espace									
DONN DP									

Grid suspension options

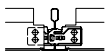
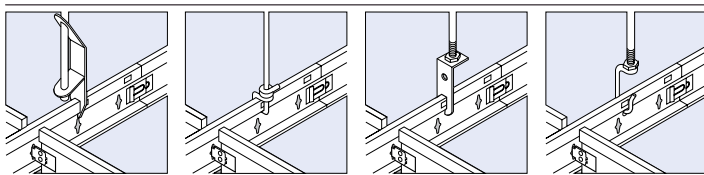

Insert into DX hole.



Rotate main tee.

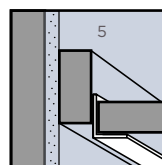
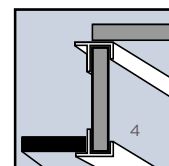
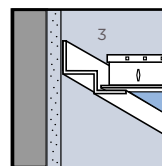
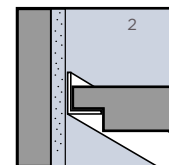
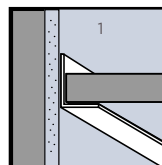
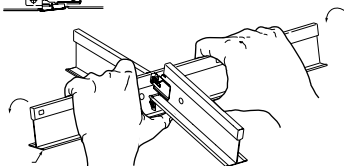
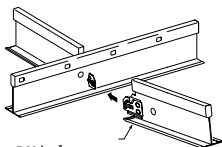

- 1- MI/L Angle with SQ edge.
- 2- L Angle-Standard angle (shown with site cut shadow edge tile).
- 3- MS-Shadowline trim
- 4- M/F Profile-for change of level and bulkheads
- 5- L Angle - Standard angle fixed to timber batten.

DONN DX is fast and simple to install. The Quick Release Clip makes it easy to remove for access and maintenance. No tools are required.

System performance

USG Boral ME ceiling systems should be installed in accordance with recommendations described within this catalogue and the DONN® grid application guide. System performance following any substitution of materials or compromises in assembly cannot be guaranteed and may result in failure under critical conditions. Reference should be made to BS 8290 1991 Suspended Ceilings parts 1, 2 and 3, and the European Standard for Suspended Ceilings BS EN 13964:2004.

Site storage and handling

Storage on site should be as short as possible with environmental conditions as near as possible to those specified for occupancy (see below). Any storage area should be secure and fully protected from the weather with cartons stored on a clean, dry base. Cartons of material should never be rolled, dropped or slid, and under no circumstances used as a workbase or substitute for ladders, scaffolding, etc.

Pattern direction

With directional face patterns, such as Glacier™ and Sandrift™, the orientation of pattern relative to light sources should be carefully considered for desired visual effect, and specified and installed accordingly. Variations in colour and fissure size in Glacier™ and Sandrift™ ceiling tiles will be of little consequence within a single production batch. However, minor variations can occur from time to time, and projects should be planned so that all material for continuous ceiling space is ordered and delivered from the same production batch. Some USG Boral ME tiles are marked with a directional arrow on the back and should always be installed with this in alignment to ensure total consistency of pattern and paint shade in a Production batch.

Overlaid material

Wherever possible, overlaid material such as insulation, should not be laid directly on the back of the ceiling membrane, as this will compromise the fire resistant properties of the ceilings. In normal conditions (BS 8290), overlaid material should not exceed 3.6kg/m² weight. For high humidity environments, overlaid installation shall be limited to 1.2 kg/m².

Installation/environmental conditions

For applications with normal controlled environmental conditions, products with 70% RH/29°C or better are suitable. Installation should only take place under ambient conditions after residual moisture from concrete and plaster has dissipated. The recommended relative humidity should not exceed 70% RH within a temperature range 65-85°F, 18-29°C for installation and occupancy.

Once ceiling installation has commenced, it is essential that RH% and temperature be maintained at acceptable levels by heating the building if necessary. Dry heating should be employed and paraffin or gas heaters avoided. These recommendations should still be applied between completion of contract and the occupation of the building. Unoccupied buildings with uncontrolled atmospheres may have a wide temperature range during a 24 hour period which could lead to an unacceptable change in dimension stability of the ceiling panels, causing excessive sag.

For applications with intermittent heating and cooling systems, products with 90%RH/32°C or better are recommended. (See Humidity selector, page 15.) For applications with uncontrolled environmental conditions, natural ventilation systems or in humid areas such as washrooms, kitchens or wet process areas, products with 95-99%RH/40°C or better are recommended. (See Humidity selector, page 15.) Radar Ceramic™ and Sonatone ceiling panels perform especially well in areas such as swimming pools, where the ceiling may be subject to unusually high levels of humidity up to 100% RH and chemical attack. They should be installed with USG Boral ME DONN® Corrosion Resistant ceiling grid and appropriate hangers to resist corrosion.

All USG Boral ME tiles should be protected from sustained direct contact with water except the treated one as water shield.

Maintenance and cleaning

General cleaning of dust and loose dirt may be easily achieved using a soft brush or vacuum cleaner. Soiled panels can be cleaned with an art gum eraser or dampened cloth or sponge containing as little water as possible.

Clean Room™ tiles can be wet wiped on a regular basis without damage.

Panels should never be soaked or immersed in water.

Cleaning can also be carried out by specialist contractors using proprietary methods and chemicals. It is strongly recommended that a trial area be cleaned to ensure that there is no detrimental effect on the ceiling panel or grid.

Re-decoration

It should be noted that a new paint finish may compromise the Surface Spread of Flame classification and acoustic absorption for that panel.

Please consult the USG Boral ME Technical Services Department for expert advice and recommendations.

Custom products

In addition to a wide standard range, USG Boral ME can satisfy specifiers' needs for non-standard, specialized ceilings. Please talk to your local USG Boral ME representative to arrange production of your specific ideas.

WALL ANGLES

System Components Construction Details

STANDARD Pre-Painted Steel (MT3600)

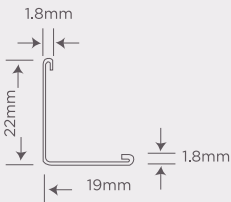

SHADOWLINE Pre-Painted Steel (MS3600) Pre-Painted Steel (MS164L)

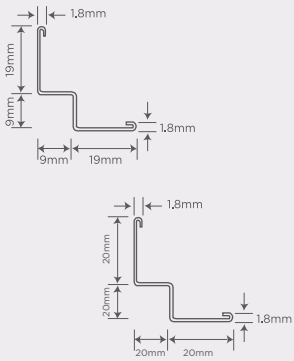

CENTRICITEE Pre-Painted Steel (M9-3600)

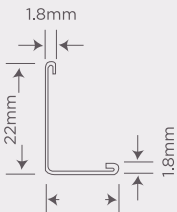

STANDARD

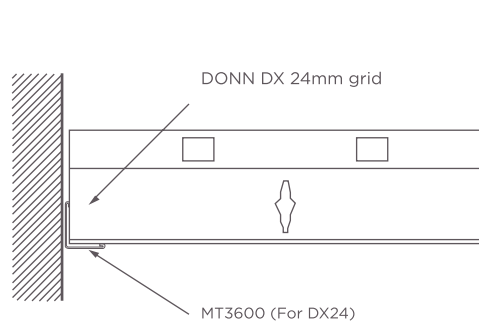

Trim to be fixed to wall, max 600mm centers. Fixing to be relevant to wall strata eg plug and screw or suitable nail type fixings.

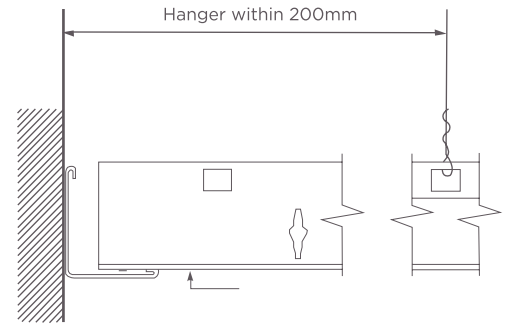

SHADOWLINE

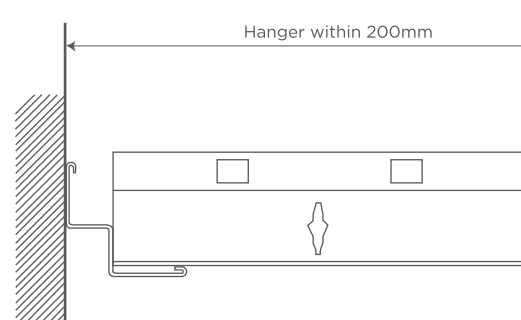

MS3600/ MS164L
Shadowline trim fixed to the perimeter wall, max 600mm centers as for standard trim

SHADOWLINE

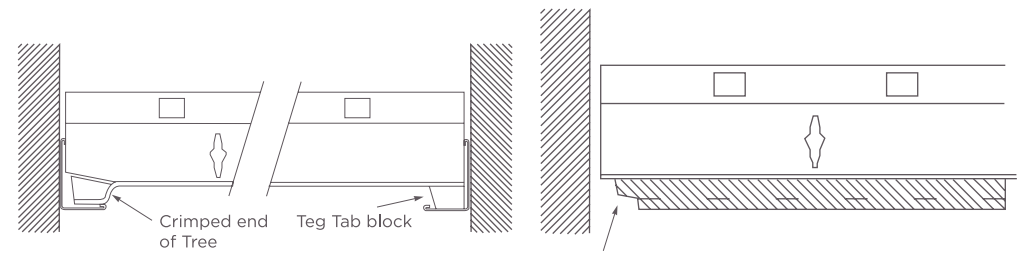

Cut, then form end with 6mm or 10mm crimping tool to suit depth of rebate on ceiling panel. When setting out ceiling plane, Lower wall angle accordingly to allow for these.

Trimmed perimeter panels hand rebated to match original rebate.

GUIDE SPECIFICATION

09120

Part 2 - Products | 2.01 System Description

Acoustical ceiling suspension system[s] conforming to ASTM C635 supplied by USG Boral ME Products, 2nd industrial city of Dammam, Saudi Arabia.

2.02 Materials

1. Web (Body) material: Hot Dipped Galvanized (HDG) steel to ASTM A635/A635M.

2. Cap material: Pre-painted Galvanized Steel or Aluminum

3. Finish on exposed cap surface:

a. Standard Painted finishes: DONN® Weiss white 10 - White- Blanc 137. Gloss level to be 15% +/- 5%.

4. Suspension system[s]:

a. Non-rated 15/16" (24mm) exposed two directional suspension system,

i. USG Boral ME DONN® DX24 intermediate duty system

ii. USG Boral ME DONN® DX24 Heavy duty System

iii. Module size to be 600x 600mm; 610 x 610mm; 600 x 1,200mm; 610 x 1,220mm; 750 x 1500mm; 762.5 x 1,525mm

b. Fire-rated 15/16" (24mm) exposed two directional suspension system certified and tested according to UL 263.

i. USG Boral ME DONN® DXL24, Heavy Duty-fire Rated System

ii. Module size to be 600x 600mm; 610 x 610mm; 600 x 1,200mm; 610 x 1,220mm; 750 x 1500mm; 762.5 x 1,525mm

c. Fire-rated 9/16" (15mm) exposed two directional suspension system certified and tested according to UL 263.

i. USG Boral ME DONN® DXLT15 Centricitiee, Heavy Duty fire rated systems.

ii. USG Boral ME DONN® DXLF Finline, Heavy Duty fire rated systems

iii. Module size to be 600x 600mm; 610 x 610mm; 600 x 1,200mm; 610 x 1,220mm; 750 x 1500mm; 762.5 x 1,525mm

d. 15/16" (24mm) DONN® DX/DXL Concealed suspension system.

5. Main runner: 1.5" (38mm) high inverted tee section of double web and cap design. Integral and reversible splice detail located at each end. Convenience holes located in the rectangular top bulb on 2.25" centers and include fire expansion notch for fire-rated main runners. Main runner length to be:

a. 3600mm with cross tee and hanger holes 75mm from each end and 150mm on center.

b. 3660mm with cross tee and hanger holes 76.25mm from each end and 152.5mm on center.

6. Cross Tee:

a. 1.5" (38mm) high inverted tee section of double web and cap design.

b. 1.3" (33mm) intermediate inverted tee section of double web and cap design.

c. 1.0" (25mm) Shallow inverted tee section of double web and cap design.

d. End detail to be stepped override design to resist twisting and provide an aesthetic hairline joint. End detail to include integral locking device for straight-in insertion and removal. Cross tee length to be:

i. 1200mm with cross tee and hanger holes at mid point

ii. 1200mm with cross tee and hanger holes at mid point

iii. 600 and 610mm short cross Tees

7. Angle Moldings:

a. Wall Angle size 22 x 19 x 3600mm long with finish on exposed surface

b. Wall Angle size 24 x 14 x 3600mm long with finish on exposed surface

c. Shadowline size 19 x 9 x 9 x 3600mm long with finish on exposed surface

8. Accessories:

a. Hanger wire. No. 12 gauge (2.7mm) galvanized, soft annealed, mild steel wire with a yield load not less than 3 times the specified (unfactored or working) design load.

DONN® SUSPENSION SYSTEM SEISMIC SOLUTIONS

Categories D, E, and F Category C

Since 1957 DONN® brand suspension systems have set the standard, using the strongest gauge steel to produce the tightest systems available with the greatest lateral and torsional stiffness. Building on this commitment to quality, USG teamed with the University at Buffalo (SUNY), the Department of Civil, Structural and Environmental Engineering - Structural Engineering and Earthquake Simulation Laboratory (SEESL) and the Earthquake Engineering Research Center (EERC) University of California, Berkeley to conduct full-scale seismic testing to evaluate and qualify the seismic performance of these systems. This testing proved that DONN® suspension systems provide a superior code-compliant solution to meeting International Building Code (IBC) requirements, including installations in Categories D, E and F, and Category C. USG is the only manufacturer to team with two separate earthquake engineering laboratories to qualify the performance of our systems.

When seismic requirements are a critical design issue, architects, contractors and building officials can rely on DONN® suspension systems to:

- Meet or exceed all national code requirements with 7/8" wall molding.
- Fulfill requirements for IBC seismic design categories C, D, E, and F.
- Provide evidence of compliance (and greatly exceed) ICC Evaluation Service, Inc. (ICC-ES) AC156 and AC368 requirements.
- Offer an aesthetically attractive option to traditional 2" angle molding.
- Provide approved solutions certified with the maximum sq. ft. weights accommodating complete ceilings systems.
- Offer compliant systems tested and verified by two separate earthquake engineering laboratories.
- Offer a seismic clip laboratory-tested to greatly exceed all structural requirements including tension, compression & tee fallout.

Seismic Qualification / Specifications

Seismic testing typically focuses primarily on the suspension system itself. Any ceiling panel can be installed in the test assembly regardless of how little it weighs, and components such as light fixtures and air handling equipment are usually excluded. In practical application, however, the suspension system must support and carry the weight of a fully functional ceiling system, including ceiling panels that can weigh as much as 2 lb./sq. ft. Therefore, USG tested suspension systems with weights commensurate with those found in real-world installations, including light fixtures and air handling equipment, using a wide variety of the ceiling panels that USG Boral ME offers. Full-scale testing performed at the University at Buffalo (SUNY) the department of Civil, Structural and Environmental Engineering - Structural Engineering and Earthquake Simulation Laboratory (SEESL) and the Earthquake Engineering Research Center (EERC) University of California, Berkeley certifies that USG Boral ME IBC-compliant assemblies are able to accommodate loads commensurate with those found in real-world installations.

Maximum Ceiling System Weight Tested

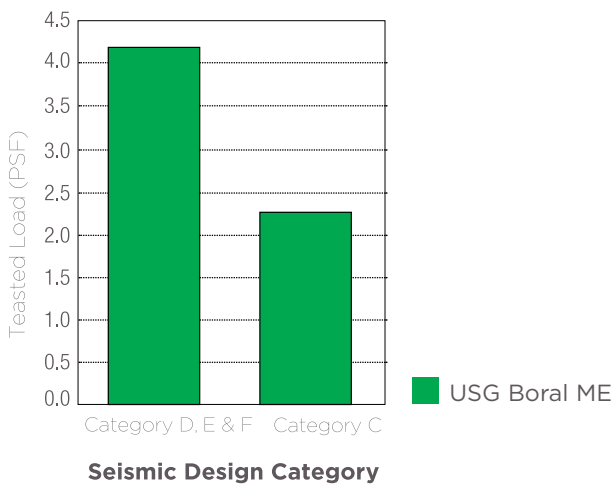

The USG figures presented are based on full-scale testing and evaluation performed at the University at Buffalo (SUNY) the department of Civil, Structural and Environmental Engineering – Structural Engineering and Earthquake Simulation Laboratory (SEESL) and the Earthquake Engineering Research Center (EERC) University of California, Berkeley. Comparative data obtained from public sources includes ICC-ES Reports, product literature and Web sites.

Testing

A complete range of USG ceiling systems was subjected to various levels of earthquake acceleration levels for the purpose of seismic qualification. The experimental studies were performed in the University at Buffalo (SUNY) the department of Civil, Structural and Environmental Engineering • Structural Engineering and Earthquake Simulation Laboratory (SEESL) and the Earthquake Engineering Research Center (EERC) University of California, Berkeley using an earthquake simulator. System performance was certified to tolerate forces in seismic Categories D, E and F that exceeded the minimum pass criterion of AC156 and AC368 by 42%.

USG Boral ME Exceeds AC156 Test Criteria

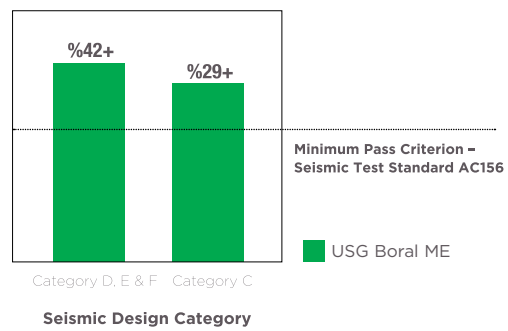

Testing per ICC Evaluation Service, Inc. (ICC-ES) AC156 and AC368:

SYSTEM DESIGN	Seismic Design Category	Maximum Ceiling System Weight Tested	Allowed Suspension System Load Carrying Capacity	Test Result
System DXL-H	D, E, F	2.50 lbs./sq.ft.	Heavy Duty	Passed
System DXL-I-C	C	2.27 lbs./sq.ft.	Intermediate Duty	Passed

With these certified IBC-compliant assemblies, USG Boral ME is the only manufacturer to offer:

- A seismic system that exceeds the minimum pass criterion of AC156 and AC368 by more than 42%.
- Seismic-system weights commensurate with typical ceiling systems.
- A seismic clip laboratory-tested to greatly exceed all structural and seismic requirements including tension, compression and tee fallout.
- Compliant systems tested and verified by two separate earthquake engineering laboratories.

Code Approval

Testing and evaluation performed at the University at Buffalo (SUNY), the Department of Civil, Structural and Environmental Engineering – Structural Engineering and Earthquake Simulation Laboratory (SEESL) and the Earthquake Engineering Research Center (EERC) University of California, Berkeley qualify the performance of these systems according to the AC156 – Seismic Qualification Specification, and AC368 – Acceptance Criteria for Suspended Ceiling Framing Systems. Several alternative materials, designs and methods of construction were evaluated and tested. Results of this investigation indicate that these tested alternative designs are at least the equivalent of that prescribed in the code for quality, strength, effectiveness, fire resistance, durability and safety. The data and test results presented provide technical evidence on which a code official can base approval. Construction details for these systems are shown on the following pages.

DONN® SUSPENSION SYSTEM SEISMIC SOLUTIONS

Categories D, E, and F Category C

Seismic Test Results

	System DXL-H	System DXL-I-C
Seismic Category	D, E, F	D, E, F
Suspension System	DONN® double-web, galvanized steel meeting or hot-dipped exceeding ASTM C635	DONN® double-web, hot-dipped galvanized steel meeting or exceeding ASTM C635
Duty rating	Heavy Duty	Intermediate Duty
Wall molding	7/8"	7/8"
Seismic Clip	ACM7	ACM7
Shake Table	Six degrees of freedom	Six degrees of freedom
Test Protocol	Simulated earthquake	Simulated earthquake
Qualification	AC156 and AC368	AC156 and AC368
Result	Passed	Passed
Minimum Acceleration Requirement	Exceeds by 42%	Exceeds by 29%
Two Adjacent Floating Sides - With Gap	Fastener attachment to tee through slot (optional), no fastener through wall molding	Fastener attachment to tee through slot (optional), no fastener through wall molding
Two Adjacent Fixed Sides - Tight, No Gap	Fastener attachment to tee (optional), one fastener through wall molding (optional)	Fastener attachment to tee (optional), one fastener through wall molding (optional)
Perimeter Wires	Yes	No
Stabilizer Bars	No	No
System Weight	2.50 lbs./sq.ft.	2.27 lbs./sq.ft.

Convenience holes located in the tee bulb may be used for any and all hanger wires. Load tests performed on 12-gauge hanger wires through convenience holes found the failure to be in excess of 400 lbs. This far exceeds the required 200 lbs. The performance of DONN® seismic systems is based on the specific combination of superior components, and design and installation methods shown. Components from other manufacturers were not evaluated, and their use or any mixed use is not recommended.

Systems Summary

	Category D,E,F Alternate Seismic Application	Standard Seismic Application
	DXL-H	
	Heavy Duty DXL-H System 7/8" Molding	Heavy Duty System 2" Molding
Suspension System Duty Rating	Heavy	Heavy
Wall Molding	7/8"	2"
Seismic Clip	ACM7	None
Two Adjacent Floating Sides - With Gap	ACM7 seismic clip with fastener attachment to tee through slot (optional), and no fastener through wall molding	No attachment of tee to molding
Two Adjacent Fixed Sides - Tight, No Gap	ACM7 seismic clip with fastener attachment to tee (optional), and one fastener through wall molding (optional)	Pop-rivet attachment of tee to molding
Perimeter Hanger Wires	Yes	Yes
Stabilizer Bars	None	Yes

	Category C Alternate Seismic Application	Standard Seismic Application
	DXL-I-C	
	Intermediate Duty System 7/8" Molding	Intermediate Duty System 7/8" Molding, Stabilizer Bars
Suspension System Duty Rating	Intermediate	Heavy
Wall Molding	7/8"	2"
Seismic Clip	ACM7	None (unless utilized in lieu of stabilizer bar)
Floating Sides - 3/8" Gap	ACM7 seismic clip with fastener attachment to tee through slot (optional), and one fastener through wall molding and one fastener through wall molding (optional)	No attachment of tee to molding
Perimeter Hanger Wires	None	None
Stabilizer Bars	None	Yes

All main DONN® suspension systems – DX®/DXL™, Finline® DXF™, Finline® 1/8 DXFF™, Centricitee™ DXT™/DXLT™, CE™, DXW™, DXLA™, and ZXLA™ – include the code-compliant intermediate-duty and heavy-duty main tees for Seismic Design Categories C, D, E, and F. For ceiling areas exceeding 2,500 ft.2 (232 m2), a seismic separation joint may be required. See SC2496 for information on seismic separation joints. The performance of DONN® seismic systems is based on the specific combination of superior components, and design and installation methods shown. Components from other manufacturers were not evaluated, and their use or any mixed use is not recommended. Convenience holes located in the tee bulb may be used for any and all hanger wires.

DONN® SUSPENSION SYSTEM SEISMIC SOLUTIONS

Categories D, E, and F Category C

System Summary

Suspension System Duty Rating	Heavy
Wall Molding	7/8"
Seismic Clip	ACM7
Two Adjacent Floating Sides - With Gap	3/49 gap; ACM7 seismic clip with fastener attachment to tee through slot (optional), and no fastener through wall molding.
Two Adjacent Fixed Sides - Tight, No Gap	Tight, no gap; ACM7 seismic clip with fastener attachment to tee (optional), and one fastener through wall molding (optional)
Perimeter Hanger Wires	Yes
Stabilizer Bars	None

Construction Details

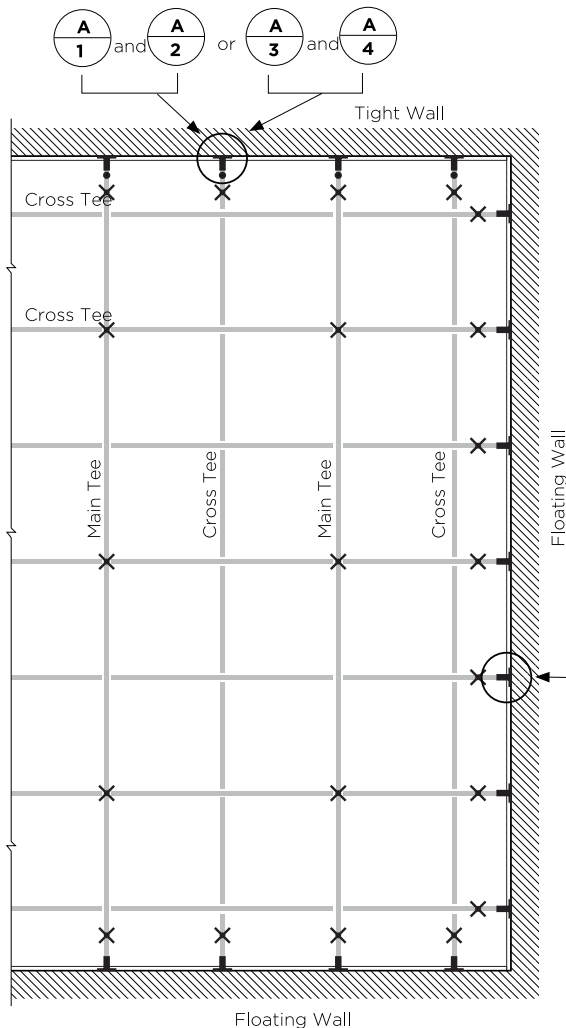

- X -12gauge hanger wire
- T ACM7 seismic clip
- T ACM7 seismic clip or riveted

All main DONN® suspension systems - DX/DXL, Finline DXF, Finline 1/8 DXFF, Centricitee DXT/DXLT, CE, DXW, DXLA, and ZXLA - include the Code compliant and heavy-duty main tees for Seismic Design Categories D, E, and F.

- A5 and A6

For ceiling areas exceeding 2,500 ft.2 (232 m²), a seismic separation joint may be required. See SC2496 for information on seismic separation joints.

The performance of DONN® seismic systems is based on the specific combination of superior components, and design and installation methods shown. Components from other manufacturers were not evaluated, and their use or any mixed use is not recommended.

Convenience holes located in the tee bulb may be used for any and all hanger wires.

ACM7 Clip, Tight Wall

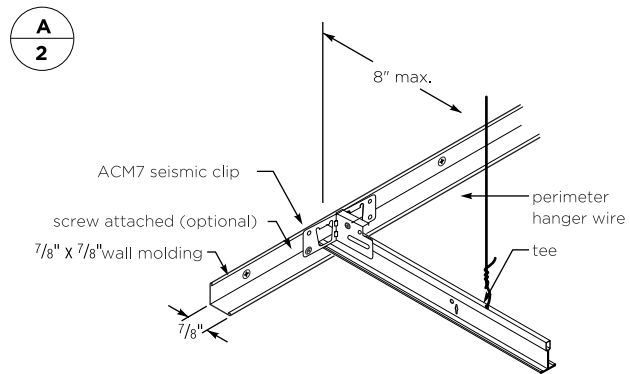
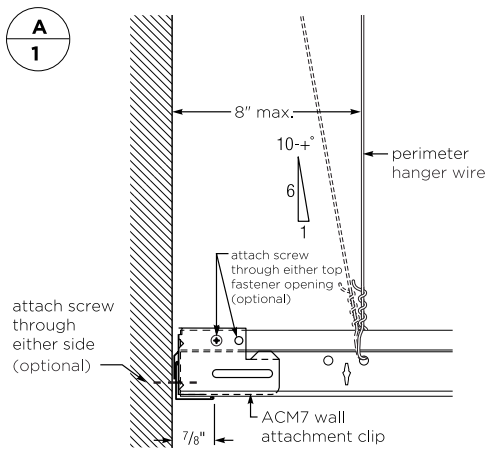

Tee Rivet, Tight Wall

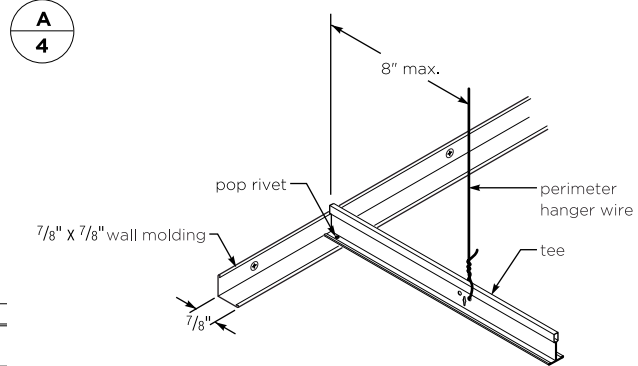
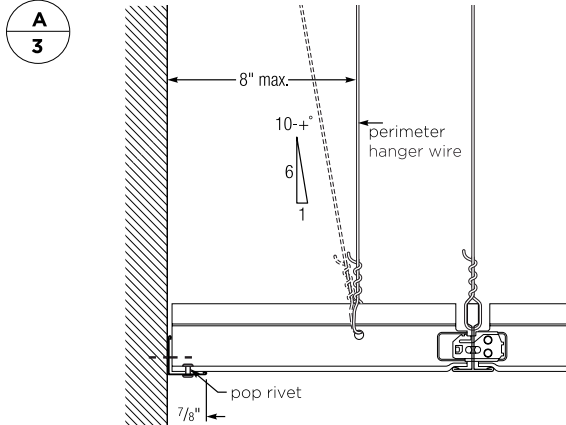

ACM7 Clip, Tight Wall

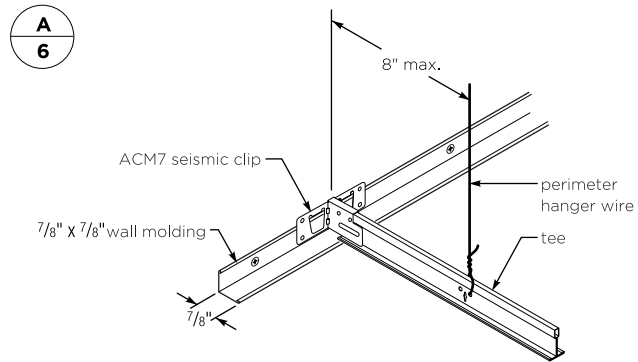
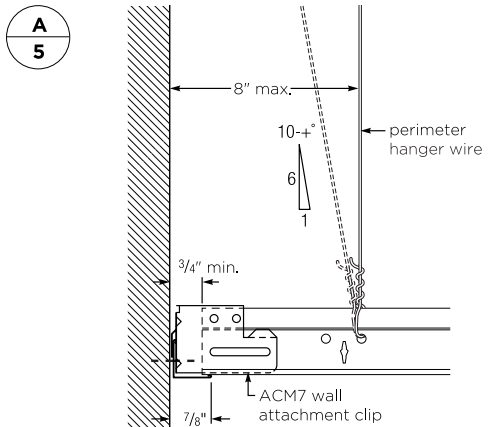

DONN® SUSPENSION SYSTEM SEISMIC SOLUTIONS

Categories D, E, and F Category C

System Summary

Suspension System Duty Rating	Heavy
Wall Molding	2"
Seismic Clip	None (unless utilized in lieu of stabilizer bars)
Two Adjacent Floating Sides - With Gap	3/4" gap; no attachment of tee to molding
Two Adjacent Fixed Sides - Tight, No Gap	Tight, no gap; pop-rivet attachment of tee to molding
Perimeter Hanger Wires	Yes
Stabilizer Bars	Yes

Construction Details

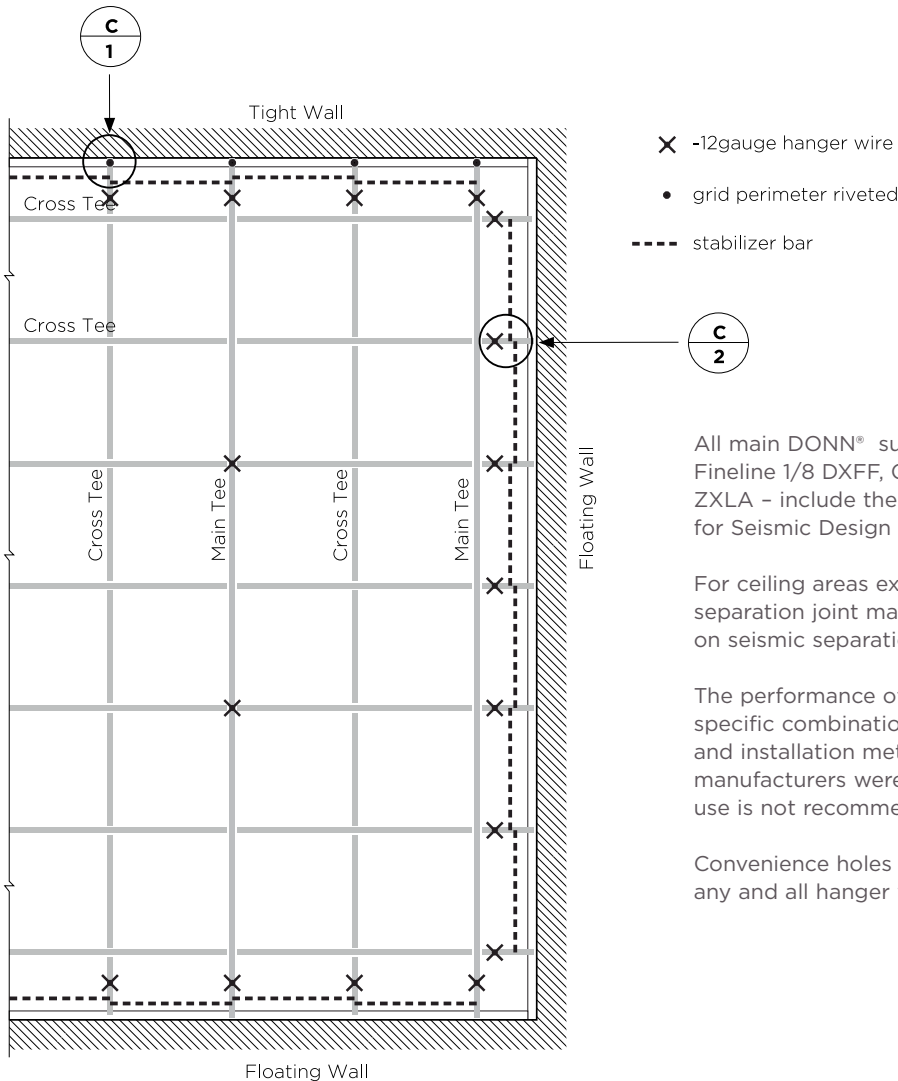

C 2

All main DONN® suspension systems - DX/DXL, Finline DXF, Finline 1/8 DXFF, Centricitee DXT/DXLT, CE, DXW, DXLA, and ZXLA - include the Code compliant heavy-duty main tees for Seismic Design Categories D, E, and F.

For ceiling areas exceeding 2,500 ft.2 (232 m²), a seismic separation joint may be required. See SC2496 for information on seismic separation joints.

The performance of DONN® seismic systems is based on the specific combination of superior components, and design and installation methods shown. Components from other manufacturers were not evaluated, and their use or any mixed use is not recommended.

Convenience holes located in the tee bulb may be used for any and all hanger wires.

Pop Rivet, Tight Wall

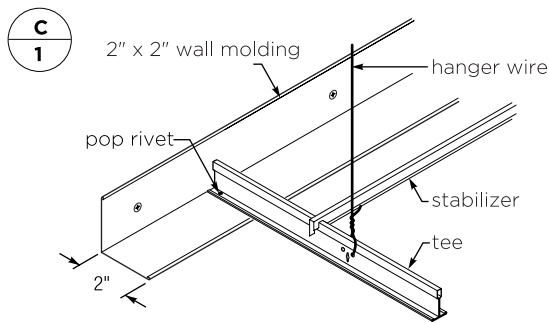

Tee Unattached, Floating Wall

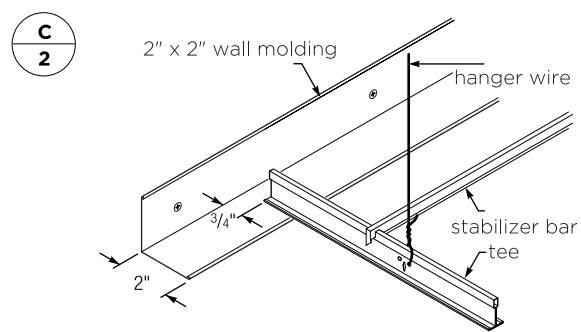

2" Seismic Shadow Molding

With a 3/4" reveal located by the wall to disguise its width, 2" shadow molding provides an aesthetically pleasing option to traditional 2" seismic molding. Designed for use with 15/16" exposed DONN® DX/DXL suspension systems, this seismic shadow molding meets or exceeds all national code requirements and fulfills requirements for Seismic Design Categories D, E, and F.

MS274

Profile

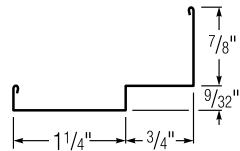
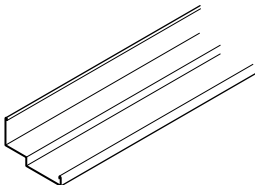

Preformed corners are available, eliminating the need to miter this molding.

Inside Corner Molding

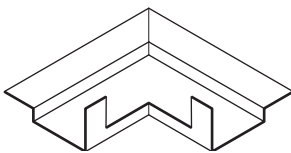

Outside Corner Molding

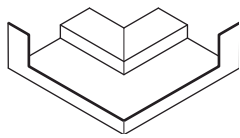

For more information about the MS274 2" seismic shadow molding, see Seismic Mold data sheet (AC3184) or Ceiling Systems catalogue (SC2000).

CATEGORY C ALTERNATE SEISMIC APPLICATION

Intermediate Duty DXL-I-C System 7/8" Molding

System Summary

Suspension System Duty Rating	Intermediate
Wall Molding	7/8"
Seismic Clip	ACM7
Two Adjacent Floating Sides - With Gap	ACM7 seismic clip with fastener attachment to tee through slot (optional), and one fastener through wall molding (optional).
Two Adjacent Fixed Sides - Tight, No Gap	Tight, no gap; pop-rivet attachment of tee to molding
Perimeter Hanger Wires	None
Stabilizer Bars	None

Construction Details

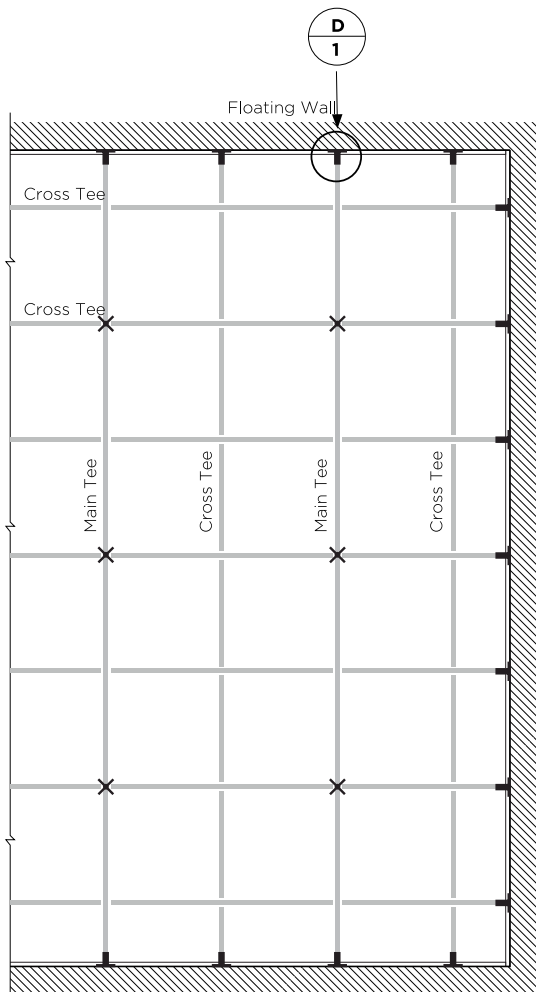

✕ -12gauge hanger wire

┌ ACM7 seismic clip

All main DONN® suspension systems - DX/DXL, Fineline DXF, Fineline 1/8 DXFF, Centricitee DXT/DXLT, CE, DXW, DXLA, and ZXLA - include the Code compliant intermediate-duty main tees for Seismic Design Categories A, B and C.

The performance of DONN® seismic systems is based on the specific combination of superior components, and design and installation methods shown. Components from other manufacturers were not evaluated, and their use or any mixed use is not recommended.

Convenience holes located in the tee bulb may be used for any and all hanger wires.
Alternate Seismic Application

ACM 7 Clip, Floating Walls

D
1

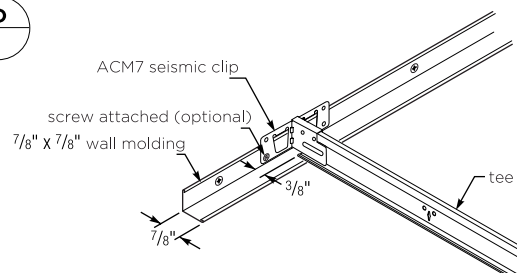

CATEGORY C STANDARD SEISMIC APPLICATION

Intermediate Duty System 7/8" Molding, Stabilizer Bars

System Summary

Suspension System Duty Rating	Intermediate
Wall Molding	7/8"
Seismic Clip	None
Floating Sides	3/8" gap; no attachment of tee to molding
Perimeter Hanger Wires	None
Stabilizer Bars	Yes

Construction Details

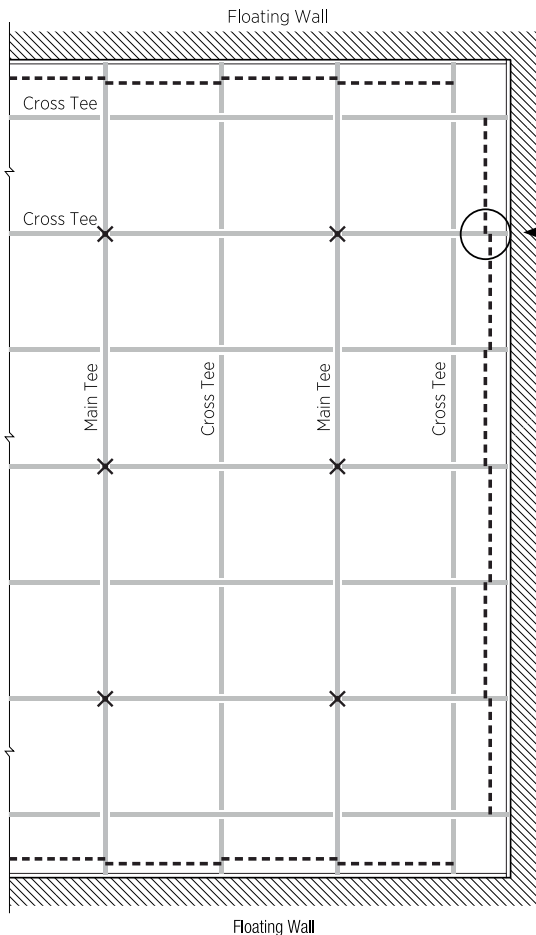

X -12 gauge hanger wire

--- stabilizer bar

E
1

All main DONN® suspension systems – DX/DXL, Finline DXF, Finline 1/8 DXFF, Centricitee DXT/DXLT, CE, DXW, DXLA, and ZXLA – include the Code compliant intermediate-duty main tees for Seismic Design Categories A, B and C.

The performance of DONN® seismic systems is based on the specific combination of superior components, and design and installation methods shown. Components from other manufacturers were not evaluated, and their use or any mixed use is not recommended.

Convenience holes located in the tee bulb may be used for any and all hanger wires.
Standard Seismic Application

Tee Unattached, Floating Wall

E
1

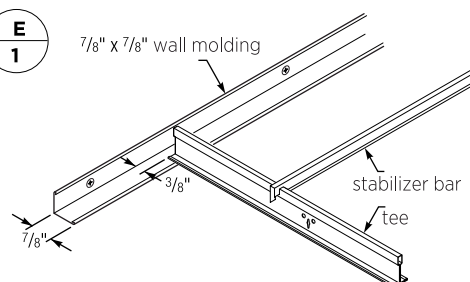



USG BORAL ME TERMS & CONDITIONS



USG BORAL ME TERMS & CONDITIONS

Delivery and Storage of Materials

A. All materials shall be delivered in their original unopened packages and stored in an enclosed shelter providing protection from damage and exposure to the elements. Never Open the cartons and keep the boards in standing position. This will boost the possibility of warpage of the tile.

B. Storage:

1. Panels: Storage time of materials at the job site should be as short as possible, and environmental conditions should be as near as possible to those specified for occupancy (see Environmental Conditions below). Excess humidity during storage can cause expansion of material and possible warp, sag, or poor fit after installation. Chemical changes in the mat and/or coatings can be aggravated by excess humidity and cause discoloration during storage, even in unopened cartons. Cartons should be removed from pallets and stringers to prevent distortion of material. Long-term (6- 12 months) storage under uncontrolled environmental conditions should be avoided.

2. Suspension System: Store in manner that will prevent warping, scratches, or damage of any kind.

C. Handling: Handle in such manner to ensure against racking, distortion, or physical damage of any kind.

D. Damaged or deteriorated materials should be removed from the premises. Immediately before installation, to stabilize tile and panels, store them at a location where temperature and humidity conditions duplicate those ambient during installation and anticipated for occupancy. In this case, refer to USG Boral ME Complaint Handling document and contact with the appropriate USG Boral ME personnel should be made within three days of receiving the material (signed delivery documentation)

Environmental Conditions

A. Installation of acoustical panels shall not begin until building is enclosed, permanent heating and cooling equipment is in operation, and residual moisture from plaster, concrete, or terrazzo work has dissipated.

B. Do not use ceiling panels in extreme or continuous high humidity, or areas exposed directly to weather or water. Ceiling panels are sized and designed for use within the standard occupancy range of temperature and humidity, 65-85 °F (18-29 °C), no more than 70% RH (relative humidity). Humidity can greatly affect product dimensional stability and sag resistance. Sag can become noticeable during periods of high humidity lasting only a few hours. CLIMAPLUS ceilings if used with DONN® Brand Suspension Systems, can withstand temperatures from 60-104 °F (32-40 °C) and relative humidity up to 95%-100% RH. See USG Boral ME for specific Warranty information.

C. Allow time for dimensional changes in ceiling panels stored at temperature/humidity conditions well outside of those recommended for service. With increases in temperature/humidity, these products expand (up to 1/64 in./ft. (4.3 mm/m) at 85 °F (29 °C)/90% RH) and may not fit into a fixed grid. Conversely, with decreases, these products will be undersize, but expand to normal when standard ambient conditions return.

D. For some pattern edge details, if perimeter panels must be cut smaller, the cut edge must be field-rabbited, or the wall angle must be lowered by (1/4") (3/8") (Reveal Depth).

E. Formaldehyde & VOC Classification, as tested per ASTM D5116 and according to standards established by the Collaborative for High-Performance Schools (CHPS), the California Office of Environmental Health Hazard Assessment (OEHHA), and the USGBC LEED for Schools.

Products are classified as zero- or low-emitting for formaldehyde and VOC emissions as defined:

a. "Zero-Emitting"

Materials producing concentration levels below the test-chamber background level specified by the "Standard Practice for the Testing of Volatile Organic Emissions from Various Sources Using Small-Scale Environmental Chambers," including 2004 addendum. Section 3.8.4.3 states, "Background concentrations in the empty chamber ventilated at 1.0 air changes per hour shall not exceed 2 µg m-3 (1.6 ppb) for any individual VOC, including formaldehyde" and all VOCs with chronic inhalation Reference Exposure Levels adopted by California EPA COEHHA for Proposition 65 chemicals.

b. "Low-Emitting"

1. Materials passing CHPS requirements as established in the «Standard Practice for the Testing of Volatile Organic Emissions from Various Sources Using Small-Scale Environmental Chambers,» including 2004 addendum. In addition, these products produce formaldehyde concentration levels below 9 µg m-3 & contribute no more than one-half of the chronic inhalation Reference Exposure Level adopted by California EPA COEHHA for all other VOCs identified by Proposition 65.

2. Must be tested by independent lab per these standards along with product submittals.

a. Documentation of laboratory test must indicate products and item number if test results differ for other facility manufacturing location for supplied products.

QUALITY ASSURANCE

A. Single Source Responsibility: To obtain combined warranty for the DONN® Brand suspension system and the acoustical panel, color match or ceiling panel and suspension system compatibility, all acoustical panel and suspension system components shall be produced and supplied by one manufacturer. Materials supplied by more than one manufacturer are not acceptable.

B. Subcontractor qualifications: Installer shall have successful experience in the installation of suspended ceiling systems on projects with requirements similar to requirements specified.

C. Requirements of regulatory agencies: Codes and regulations of authorities having jurisdiction.

D. Source quality control:

1. Test reports: Manufacturer will provide test certification for minimum requirements as tested in accordance with applicable industry standards and/or to meet performance standards specified by various agencies.

2. Changes from system: System performance following any substitution of materials or change in assembly design must be certified by the manufacturer.

PROJECT CONDITIONS

A. Existing conditions: (include specific alteration work requirements for project).

B. Environmental requirements for interior installation: Building shall be enclosed with windows and exterior doors in place and glazed, and roof watertight before installation of ceiling system and related ceiling components. Climatic Condition Range for panels used on this project are as follows:

1. ClimaPlus Ceilings: 60-90°F (16-29°C) with a max 99% RH.

CLIMAPLUS ceilings used with DONN® Brand Suspension Systems can be used when building is not enclosed and in higher temperature, relative-humidity range.

C. Coordination with other work:

1. General: Coordinate with other work supported by or penetrating through the ceiling, including mechanical and electrical work and partition systems.

2. Mechanical work: Ductwork above ceiling shall be completed and permanent heating and cooling systems operating to climate conditions prior to installation of ceiling components.

3. Electrical work: Installation of conduit above ceiling shall be complete before installation of ceiling components.

4. Fire protection work: Fire protection lines and/or equipment occurring above ceiling shall be completed and tested before ceiling components are installed.

D. Protection:

1. Personnel: Follow good safety and industrial hygiene practices during handling and installing of all products and systems, with personnel to take necessary precautions and wear appropriate personal protective equipment as needed. Read material safety data sheets and related literature for important information on products before installation. Contractor to be solely responsible for all personal safety issues during and subsequent to installation; architect, specifier, owner, and manufacturer will rely on contractor's performance in such regard.

2. Protect completed work above ceiling system from damage during installation of ceiling components.

INSPECTION

A. Examine areas to receive ceiling panels for conditions that will adversely affect installation. Provide written report of discrepancies.

B. Do not start work until unsatisfactory conditions are corrected.

C. Work to be concealed: Verify work above ceiling is completed and installed in manner that will not affect layout and installation of ceiling panels.

D. Beginning of installation shall signify acceptance of conditions in areas to receive ceiling panels.

ENVIRONMENTAL CONDITIONS

A. Installation of acoustical panels shall not begin until building is enclosed, permanent heating and cooling equipment is in operation, and residual moisture from plaster, concrete, or terrazzo work has dissipated.

B. Do not use ceiling panels in extreme or continuous high humidity, or areas exposed directly to weather or water. Ceiling panels are sized and designed for use within the standard occupancy range of temperature and humidity, 65-85 °F (18-29 °C), no more than 95% of ClimaPlus.

PREPARATION

Field dimensions must be verified prior to installation.

INSTALLATION

A. Standard reference: Install ceiling panels and suspension system, including necessary hangers, grillage, splines, and other supporting hardware, in accordance with ASTM C636, 2006 IBC (2007 CBC), CISCA Ceiling Systems Handbook, (UL Design) and any applicable code requirement.

B. Manufacturer's reference: Install ceiling panels in exposed grid systems, supported on all edges, in accordance with manufacturer's warranty.



USG BORAL ME TERMS & CONDITIONS

C. Drawing reference: Install ceiling panels in accordance with approved shop drawings.

D. Hanger Wires:

1. Spacing: Space hanger wires on main tees not more than 48 inches o.c. a maximum of 48" o.c., attaching hangers directly to the structure above, or as required to support loads.

2. Limitations: Do not support wires from mechanical and/or electrical equipment, piping or other equipment occurring above ceiling.

E. Ceiling Perimeter: Install edge moldings (2" minimum) and trim of type indicated at perimeter of acoustical ceiling area and where necessary to conceal edges of acoustical panels.

1. Tee ends shall be tied together with DONN® Brand Stabilizer Bars or other approved means to prevent the tees from spreading apart.

2. Mechanically attach the terminal ends of the ceiling suspension members to the perimeter molding of two adjoining walls using pop-rivets or other approved means.

3. Maintain a 3/4" clearance between the opposite ends of the suspension members and the wall. The unattached ends of the suspension members shall rest upon and be free to slide perpendicularly to the perimeter molding.

F. Alternate Perimeter Attachment: When approved by local code officials install 7/8" edge molding with ACM7 Seismic Clip - Install per USG Boral ME literature AC3235.

G. Accessories: Install accessories as applicable to meet project requirements.

H. Install edge moldings and trim of type indicated at perimeter of acoustical ceiling area and where necessary to conceal edges of acoustical tiles.

I. Install suspension system runners so they are square and securely interlocked with one another. Remove and replace dented, bent, or kinked members.

J. Install acoustical tiles in coordination with suspension system.

1. Fit adjoining tile to form flush, tight joints. Scribe and cut tile for accurate fit at borders and around penetrations through tile.

2. Remove and replace any damaged tiles.

K. Lighting Fixtures:

1. All light fixtures shall be mechanically attached to the suspension system per NEC 410-16 (two per fixture unless the fixture is independently supported).

2. Support of rigid lay-in (Type G) or can light fixtures:

a. Each fixture less than 4.5 Kg shall have a single wire (wire may be slack) attached from the fixture to structure.

b. Each fixture that weighs between 4.5 and 25 Kg shall have two wires (wires may be slack) attached at diagonal corners of the fixture to structure.

c. Each fixture greater than 25 Kg shall be directly supported to structure by approved hangers.

d. Pendant light fixtures shall be directly supported from structure with 9-gauge wire (or approved alternative).

L. Air Terminals:

1. Air terminals less than 9 Kg shall be positively attached to the suspension system

2. Air terminals that weigh between 9 Kg and 25 Kg shall be mechanically attached to the suspension system. Two slack wires shall be attached from the housing to structure.

3. Air terminals in excess of 56 lbs. shall be directly supported to structure by approved hangers.

M. Sprinkler heads and other penetrations shall have 3/8" clearance on all sides.

CLEANING

A. Suspension System: Remove panel material and perform any necessary cleaning maintenance with non-solvent based commercial cleaner.

B. Immediately remove any corrosive substances or chemicals that would attack painted finishes (i.e. wallpaper adhesives).

C. Touch up all minor scratches and spots, as acceptable, or replace damaged sections when touch-up is not permitted.

D. Painting: Repainting of suspension member shall be with a high-quality solvent base enamel paint and applied as recommended by paint manufacturer. Ceiling panels may be touched-up by spraying a thinned, non-bridging vinyl-acrylic flat wall paint. The type of paint selected and the method of application can alter the acoustical performance and fire ratings of any acoustical product. Therefore, USG Boral ME cannot guarantee that the field-painted panels will match the published performance.

E. Removal of debris: Remove all debris resulting from work of this section.

PACKAGING FOR CEILING SYSTEM

THICKNESS	FAMILY TYPE/SIZE	NUMBER OF TILES PER CARTON PCS/CTN	M ² PER CARTON M ² /CTN	NUMBER OF BOXES / PER PALLET CTN/PALLET	M ² PER PALLET M ² /PALLET	BOX WEIGHT KG/CTN	PALLET WEIGHT KG/PALLET
12 mm	STD 600*600mm	16	5.76	52	299.52	21.6	1,123.26
	STD 610*610mm	16	5.95	52	309.5	22.3	1,160.64
15 mm	STD/C+ 600*600mm	12	4.32	56	241.92	15.3	856.80
	STD/C+ 610*610mm	12	4.46	56	249.98	15.8	884.57
	C+ 600*1200mm	8	5.76	40	230.40	20.4	816.00
	C+ 610*1220mm	8	5.95	40	238.08	21.1	842.92
	Olympia™ STD/C+ 600*600mm	12	4.32	56	241.92	16.7	932.40
	Olympia™ STD/C+ 610*610mm	12	4.46	56	249.98	17.2	962.62
	Olympia™ C+ 600*1200mm	8	5.76	40	230.40	22.2	888.00
	Olympia™ C+ 610*1220mm	8	5.95	40	238.08	22.9	917.29
	Fire Chief 600*600mm	12	4.32	48	207.36	21.7	1,041.60
	Fire Chief 600*610mm	12	4.46	48	214.27	22.4	1,075.36
	Olympia™ Fire Chief 600*600mm	12	4.32	48	207.36	22.8	1,094.40
	Olympia™ Fire Chief 600*610mm	12	4.46	48	214.27	23.5	1,129.87
	Fire Chief 600*1200mm	8	5.76	40	230.40	28.9	1,157.33
	Fire Chief 600*1220mm	8	5.95	40	238.08	29.9	1,195.51
	Olympia™ Fire Chief 600*1200mm	8	5.76	40	230.40	30.4	1,216.00
	Olympia™ Fire Chief 610*1220mm	8	5.95	40	238.08	31.4	1,256.53
	Plank 300*1200mm	12	4.32	44	190.08	15.7	690.80
	Plank 310*1220mm	12	4.46	44	196.42	16.2	713.19
Plank Olympia™ 300*1200mm	12	4.32	44	190.08	16.7	732.60	
Plank Olympia™ 310*1220mm	12	4.46	44	196.42	17.2	756.34	
19 mm	STD/C+ 600*600mm	10	3.60	52	187.20	16.0	832.00
	STD/C+ 610*610mm	10	3.72	52	193.44	16.5	859.73
	C+ 600*1200mm	6	4.32	40	172.80	19.2	768.00
	C+ 610*1220mm	6	4.46	40	178.56	19.8	793.60
	Olympia™ STD/C+ 600*600mm	10	3.60	52	187.20	17.6	912.60
	Olympia™ STD/C+ 610*610mm	10	3.72	52	193.44	18.1	943.02
	Olympia™ C+ 600*1200mm	6	4.32	40	172.80	20.9	834.00
	Olympia™ C+ 610*1220mm	6	4.46	40	178.56	21.5	861.80
	Fire Chief 600*600mm	10	3.60	40	144.00	24.7	986.00
	Fire Chief 600*610mm	10	3.72	40	148.80	25.5	1,018.87
	Olympia™ Fire Chief 600*600mm	10	3.60	40	144.00	25.7	1,026.00
	Olympia™ Fire Chief 600*610mm	10	3.72	40	148.80	26.5	1,060.20
	Fire Chief 600*1200mm	6	4.32	40	172.80	29.6	1,183.20
	Fire Chief 600*1220mm	6	4.46	40	178.56	30.6	1,222.64
	Olympia™ Fire Chief 600*1200mm	6	4.32	40	172.80	30.8	1,231.20
	Olympia™ Fire Chief 610*1220mm	6	4.46	40	178.56	31.8	1,272.24
	Halcyon™ 600*600mm	10	3.60	40	144.00	7.5	300.00
	Halcyon™ 600*610mm	10	3.72	40	148.80	7.8	310.00
	Halcyon™ 600*1200mm	6	4.32	40	172.80	9.0	360.00
	Halcyon™ 610*1220mm	6	4.46	40	178.56	9.3	372.00
	Plank 300*1200mm	10	3.60	44	158.40	16.0	704.00
	Plank 310*1220mm	10	3.72	44	163.68	16.5	727.47
	Plank Olympia™ 300*1200mm	10	3.60	44	158.40	17.6	772.20
	Plank Olympia™ 310*1220mm	10	3.72	44	163.68	18.1	797.94
	Plank Sonata/Oly 300*1500mm	10	4.50	60	270.00	22.1	1,327.50
	Plank Sonata/Oly 310*1520mm	10	4.64	60	278.16	22.8	1,367.62
	Plank Sonata/Oly 600*1500mm	6	5.40	30	162.00	26.6	796.50
	Plank Sonata/Oly 610*1520mm	6	5.56	30	166.90	27.4	820.57

THICKNESS	FAMILY TYPE/SIZE	NUMBER OF TILES PER CARTON PCS/CTN	M ² PER CARTON M ² /CTN	NUMBER OF BOXES / PER PALLET CTN/PALLET	M ² PER PALLET M ² /PALLET	BOX WEIGHT KG/CTN	PALLET WEIGHT KG/PALLET
22 mm	STD/C+ 600*600mm	8	2.88	40	115.20	18.5	741.89
	STD/C+ 610*610mm	8	2.98	40	119.04	19.2	766.62
	C+ 600*1200mm	6	4.32	40	172.80	27.8	1,112.83
	C+ 610*1220mm	6	4.46	40	178.56	28.7	1,149.93
	Olympia™ STD/C+ 600*600mm	8	2.88	40	115.20	19.5	781.89
	Olympia™ STD/C+ 610*610mm	8	2.98	40	119.04	20.2	807.95
	Olympia™ C+ 600*1200mm	6	4.32	40	172.80	29.3	1,172.83
Olympia™ C+ 610*1220mm	6	4.46	40	178.56	30.3	1,211.93	
25 mm	Halcyon™ 600*600mm	8	2.88	40	115.20	6.9	276.00
	Halcyon™ 610*610mm	8	2.98	40	119.04	7.1	285.20
	Halcyon™ 600*1200mm	4	2.88	40	115.2	10.4	414.00
	Halcyon™ 610*1220mm	4	2.98	40	119.04	10.7	427.80

	ITEM CODE	NUMBER OF PIECES PER CARTON PCS/Ctn
MAIN TEES	801DX3600H	25
	801DX3600IM	25
	801DX3660H30	25
	801DX3660IM	25
	801DXL3600	25
	801DXL3660	25
	801DXT15-3600M	20
	801DXT15-3660IM	20
WALL ANGLES	802M9-3600	40
	802MS3600	50
	802MT3600	40
LONG CROSS TEES (4 FT)	803DX1200H30	50
	803DX1200LM	75
	803DX1220H30	50
	803DX1220LM	75
	803DXT15-1200M	60
	803DXT15-1220IM	60
SHORT CROSS TEES (2 FT)	804DX600H30	50
	804DX600LM	75
	804DX610H30	50
	804DX610LM	75
	804DXT15-600M	60
	804DXT15-610IM	60



WARRANTIES AND LIMITATIONS

USG Boral ME following combinations of ceiling system products, as installed in the building nominated overleaf, carry a lifetime warranty from the date of installation (“Warranty Period”). Lifetime is defined as the useful life of the ceiling system up to a maximum of 30 years. USG Boral ME acoustical panel only or USG Boral DONN® grid only, carry a 15 year warranty from date of installation.

WHAT PRODUCTS ARE COVERED ?

This Warranty covers the standard sizes 1200 x 600 and 600 x 600 mm it includes the following products:

USG Boral ME CLEAN ROOM™	USG Boral ME RADAR™
USG Boral ME SPARTA	USG Boral ME FROST™
USG Boral ME RADAR Ceramic™	USG Boral ME HALCYON™
USG Boral ME CROSS FISSURED	USG Boral ME MARS™
USG Boral ME LOUNA	USG Boral ME LOUNA HICAC
USG Boral ME METAL FACE	USG Boral ME PERFORATED / USG Boral ME DONN® DX 24 mm Exposed Grid
USG Boral ME SONATA	USG Boral ME PEDESTAL / USG Boral ME DONN® Centricitee 15 mm Exposed Grid
USG Boral ME OLYMPIA Micro™ ClimaPlus	USG Boral ME SANDRIFT™ / USG Boral ME DONN® DXF Fine Line Grid
USG Boral ME OLYMPIA II™ ClimaPlus	USG Boral ME TAIGA HYGIENE

WHAT DOES THIS WARRANTY COVER ?

This Warranty covers the owner (and subsequent owners) of the building nominated overleaf in which the products are installed for the Warranty Period.

Product defects caused by faulty materials, manufacturing workmanship and failure to meet product specifications issued by USG Boral ME in effect at the time of installation.

The nominated ceiling panels shall withstand normal climatic conditions including high temperature and humidity without visible sagging, warping or shrinking, or delamination of finished surfaces, provided that the panels are installed in normal occupancy conditions for which they are intended and within current environmental conditions of the product.

What Will USG Boral ME Do ?

USG Boral ME at our election will replace or repair the defective product or, refund or credit an amount equal to the purchase price of the defective products and transportation net of all taxes, charges or other levies paid. This constitutes USG Boral ME’s entire liability.

WHAT DOES THIS WARRANTY NOT COVER?

This Warranty does not cover defects arising from a failure to comply with USG Boral ME’s printed Guidelines, Limitations, Specifications, Installation Instructions and Standards, before, during and after installation. In particular the Warranty does not cover damage to the products arising from:

- Abnormal climatic conditions outside the products specification.
- Exterior applications.
- Chemical fumes*, corrosive substances, freezing temperatures or vibration.
- Ceiling panels used to support any other materials or fixtures such as lights, air conditioning grilles, insulation (which are above maximum Back loading limitations), signs etc.
- Ceiling panels installed on furring strips, or if nails, staples or adhesives have been used in the installation process.
- Damage by fire, water (including condensation) or other elements of nature or act of God.
- Accidents, abuse, neglect deterioration by chemical action, damage during shipment, storage, installation or used for purposes other than for which they were designed.
- Other components in the ceiling systems not manufactured by USG Boral ME Interiors such as hanger wires, fasteners, accessories.
- Alteration or removal of products without the prior approval of USG Boral ME Interiors or attempts to repair any defective products.
- Warpage or sag occurrence due to panels kept outside the box in standing position or panels with edge details inappropriately cut and installed at perimeter without being field rabbited.

*Radar Ceramic™ ClimaPlus will withstand corrosive chemical fumes

ALSO THIS WARRANTY DOES NOT COVER:

- Costs of removal or installation of products
- Cost of removal of damaged or installed faulty product
- Any direct, indirect or consequential damage or loss of any nature

IF YOU HAVE A PROBLEM?

USG Boral ME will only accept claims in writing made in accordance with this warranty, and

- within the Warranty Period, and
- within 30 (thirty) days from the date the problem was, or by reasonable inspection should have been, discovered, and
- with proof of installation (to assist, fill out details below)

You must keep any products that are alleged to be defective for our inspection and you must not attempt to alter, repair or remove these products.

OTHER LEGAL RIGHTS:

This Warranty is not part of a contract between USG Boral ME and the building owner. USG Boral ME shall not be bound by any unauthorized warranty given by the seller of the products or the contractor. It does not exclude, limit, restrict or modify the rights and remedies available to the building owner, or the liability of the seller or contractor, under any statute or other laws in respect of the products and, in particular, when the goods are supplied to the final Consumer

PROJECT DETAILS:

NAME :

ADDRESS:

COUNTRY:

OWNER :

LIFETIME / 15 YEAR CEILING SYSTEM WARRANTY

PRODUCT :

Panel : USG Boral ME 00 x 00 x 1 mm m²

Grid : USG Boral ME DONN® 00 x 00 mm m²

DATE OF INSTALLATION: 20

CEILING SYSTEMS CONTRACTOR:

NAME :

ADDRESS:

SIGNATURE:

TITLE :

DATE :

WARRANTY COPIES:

BUILDING OWNER

CEILING CONTRACTOR

USG BORAL ME

Australia
China
India
Indonesia
Malaysia
Middle East
New Zealand
Thailand
Philippines
Singapore
South Korea
Vietnam

**7410 (Wasil), Street #23, Cross 76, 2nd Industrial City
Dammam 34326-4201, Kingdom of Saudi Arabia**